



SELF-CONTAINED HEAT PUMP PACKAGE UNITS

FORM NO. P11-769 REV. 3
Supersedes Form No. P11-769 Rev. 2

Featuring New Industry Standard R-410A Refrigerant

R-410A

RQNM- 13-SEER SERIES
NOMINAL SIZES 2-5 TONS [7-17.6 kW]

RQPM- 14-SEER SERIES
NOMINAL SIZES 2-5 TONS [7-17.6 kW]





Unit Features & Benefits	3-6
Model Identification Options	7
General Data	
RQNM- Series	8-10
RQPM- Series	11-14
General Data Notes	15
Performance Data	
RQNM- Cooling Series	16-19
RQPM- Cooling Series	20-23
RQNM- Heating Series	24-26
RQPM- Heating Series	27-31
Airflow Performance RQNM- Series.....	32-33
Airflow Performance RQPM- Series.....	34-35
Electrical Data	
RQNM- Series	36
RQPM- Series	37-38
Electric Heater Kits	39-42
Dimensional Data.....	43
Typical Installations	44
Accessories.....	45
Typical Wiring	46-51
Limited Warranty	52



UNIT FEATURES & BENEFITS—RQNM/RQPM- SERIES

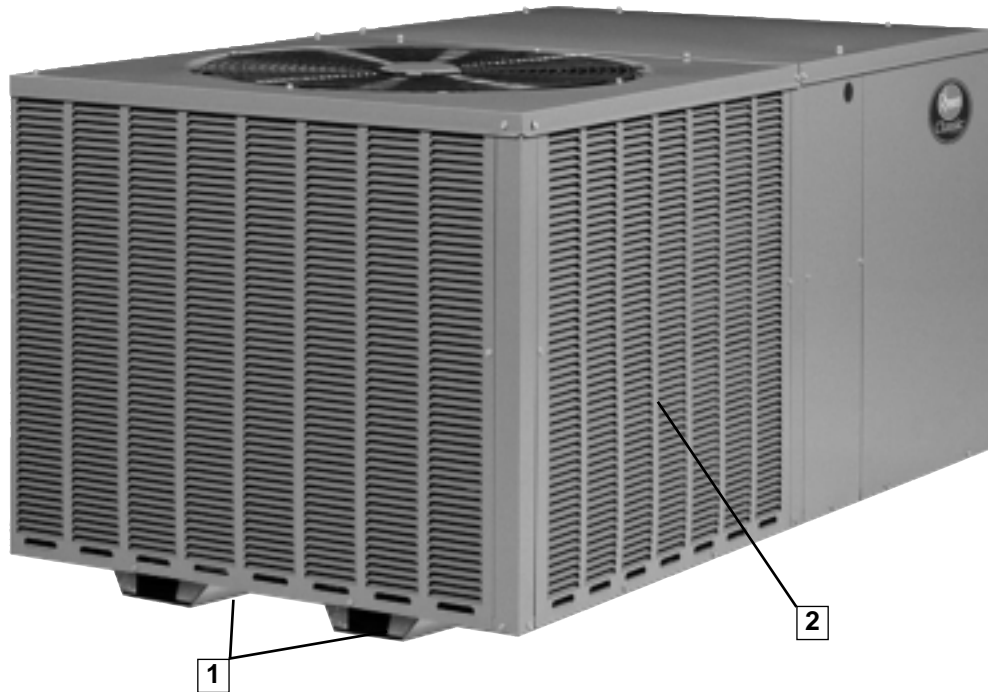

The RQNM & RQPM series of Package Heat Pumps are designed to be the most efficient, quickest to install, easiest to service, and most reliable units in the industry - while still maintaining an affordable price. This platform provides you with a full line of nominal capacities from 2 through 5 tons. RQNM models are 13 SEER and RQPM models are 14 SEER, each ARI-certified.

As with all units offered by Rheem, we started our design process with input from the customer. From fan grille to the base rails, Rheem has combined 30 years worth of package unit design experience with input from Dealers to meet the latest application requirements.

Starting at the bottom, the base rails (1) allow for separation between the unit base and the ground level, protecting the base from ground moisture and providing air circulation around the unit. Constructed from sturdy 18-gauge G-90 sheet metal, the base rails also allow for easier maneuverability during installation.

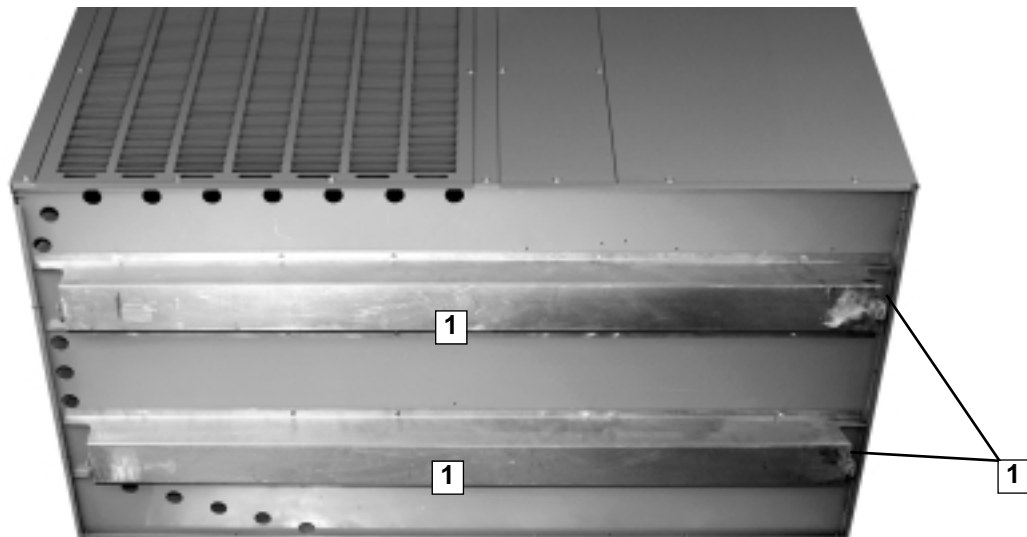



While other manufacturers have chosen to use pre-painted steel in their equipment, which exposes raw edges and invites rust and sharp edges, Rheem package equipment uses a powder-coat paint system, rated at 1000 hour salt spray per ASTM B117. The powder-coat process also greatly diminishes and dulls sharp edges, reducing the occurrence of cuts and torn clothes.

To provide flexibility in space-limited installations, the unit can be installed flush to the structure without blocking airflow over the outdoor coil or making any screws inaccessible for maintenance. Furthermore, the cabinet is a slim 33" wide. Full-louver coil protection (2) makes Rheem unique in the industry and also totally protects the outdoor coil from vandalism and weather extremes.

Two round 14" duct collar (3) are included with the unit, which makes attaching duct a snap. The collar is crimped around the leading edge, making it easier to install duct onto the collar. A metal bead around the circumference prevents the attached ducting from sliding off after installation.

Keeping service technicians in mind, Rheem takes pride providing easy access to internal components. The outdoor-section top cover (4) is easily removed to allow access to the scroll compressor (5), outdoor fan motor (6), and refrigerant tubing (7).

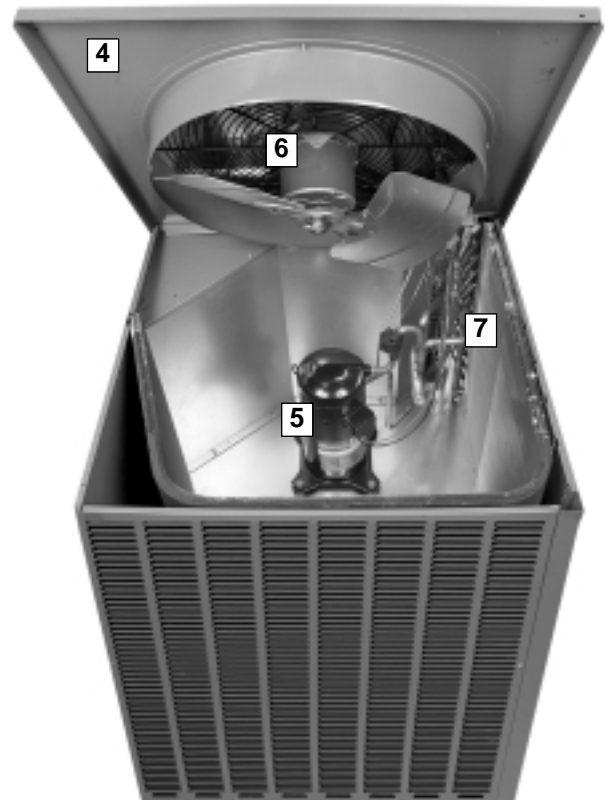



UNIT FEATURES & BENEFITS—RQNM/RQPM- SERIES

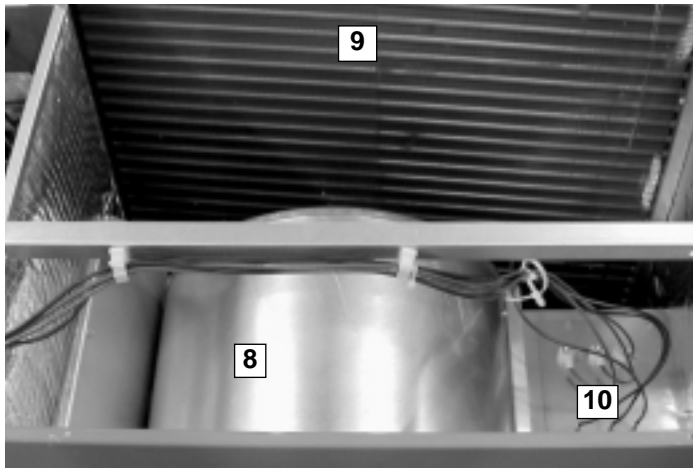

The indoor-section top cover also easily opens to access the removable blower housing and motor (8). This also gains total access to the indoor coil for cleaning and service (9).

The indoor motor and blower system will achieve nominal 400 CFM per ton up to a minimum of .8 inches of static pressure, which helps to eliminate customer dissatisfaction over poor airflow brought about by high-static duct designs.

Optional electric heat (10) can be easily installed in the field, with either dual- or single-point power, and is designed to easily install into the unit. Electric heat can also be specified as factory installed.

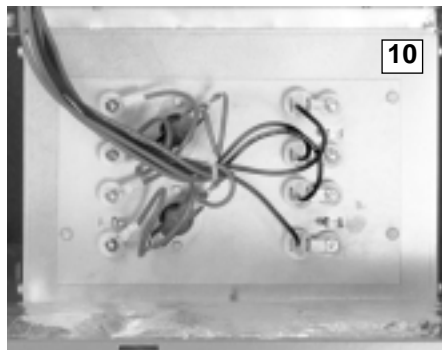

The controls are located in a large, easy-to-access control box (11), which provides plenty of space in which to troubleshoot. A demand defrost control (12) is used to manage the defrost cycle. The transformer (13) is protected by a in-line fuse, which protects the transformer during a low-voltage electrical short. The low-voltage (14) and high-voltage (15) wiring connections are easily accessed and have ample room around which to maneuver. Troubleshooting is further aided with number- and color-coded wiring, which corresponds with the large, easy-to-read wiring diagram located on the inside of the control box access panel.

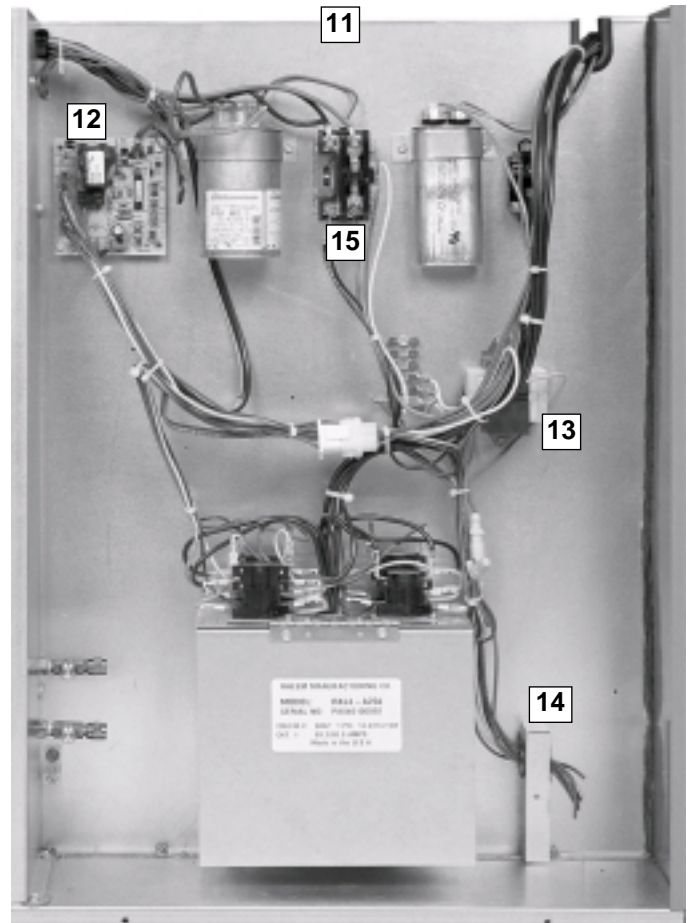



High and low pressure can easily and accurately be measured using the two gauge ports (16) located inside the control box.

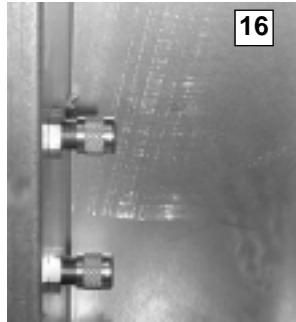

Foil-faced insulation is securely glued and captured to the cabinet. On the base of the unit, closed-cell insulation is used to prevent moisture from being absorbed and help reduce mold content to provide better indoor air quality.

For reliability and long-lasting operation, Rheem uses 100% scroll compressor technology (19) on all package platforms. With over 12 years of history, the scroll compressor has proven to be reliable, efficient, and quiet during operation.



A small side panel grants access to a removable, sloped drain pan (17), which helps to ensure indoor air quality (IAQ) throughout the life of the unit. A 3/4" drain trap (18) assembly is provided for convenience.





MODEL IDENTIFICATION—RQNM/RQPM- SERIES



R Q N M — A 036 J K 010

Heating Capacity (Factory Installed)
000 = No Resistance Heat
005 = 05 KW Resistance Heat
007 = 07 KW Resistance Heat
010 = 10 KW Resistance Heat
015 = 15 KW Resistance Heat
020 = 20 KW Resistance Heat

Drive Package
K = Direct Drive

Electrical Designation
J = 208-230V—1PH—60 Hz
C = 208-230V—3PH—60 Hz
(13 SEER Only)

Nominal Cooling Capacity (BTUH) [kW]
024 = 24,000 [7.03]
030 = 30,000 [8.79]
036 = 36,000 [10.55]
037 = 36,000 [10.55]
042 = 42,000 [12.31]
048 = 48,000 [14.07]
049 = 48,000 [14.07]
060 = 60,000 [17.59]

Future Technical Variations

Design Series
M = R-410A

Efficiency Designation
N = 13 SEER
P = 14 SEER

Product Classification
Q = Package Heat Pump

Tradebrand
R = Rheem

[] Designates Metric Conversions



NOMINAL SIZES 2-5 TONS [7-17.6 kW]

Model RQNM- Series	A024JK	A030JK	A036CK	A036JK
Cooling Performance¹				CONTINUED →
Gross Cooling Capacity Btu [kW]	24,600 [7.21]	29,800 [8.73]	36,600 [10.72]	36,600 [10.72]
EER/SEER ²	11/13	11.15/13	11/13	11/13
Nominal CFM/ARI Rated CFM [L/s]	800/800 [378/378]	1000/1000 [472/472]	1200/1200 [566/566]	1200/1200 [566/566]
ARI Net Cooling Capacity Btu [kW]	23,600 [6.91]	28,800 [8.44]	35,200 [10.31]	35,200 [10.31]
Net Sensible Capacity Btu [kW]	18,200 [5.33]	22,400 [6.56]	27,000 [7.91]	27,000 [7.91]
Net Latent Capacity Btu [kW]	5,400 [1.58]	6,400 [1.88]	8,200 [2.4]	8,200 [2.4]
Net System Power kW	2.14	2.58	3.2	3.2
Heating Performance (Heat Pumps)³				
Heating Input Btu [kW] Rating	23,400 [6.86]	28,800 [8.44]	35,000 [10.26]	35,000 [10.26]
System Power KW/COP	2.07/3.34	2.45/3.44	2.95/3.48	2.95/3.48
Low Temp. Btuh [kW] Rating	13,800 [4.04]	16,200 [4.75]	19,200 [5.63]	19,200 [5.63]
System Power KW/COP	1.91/2.12	2.22/2.14	2.65/2.1	2.65/2.1
HSPF (Btu/Watts-hr)	7.7	7.7	7.7	7.7
Compressor				
No./Type	1/Scroll	1/Scroll	1/Scroll	1/Scroll
Outdoor Sound Rating (dB)⁴	76	76	76	76
Outdoor Coil—Fin Type	Louvered	Louvered	Louvered	Louvered
Tube Type	Rifled	Rifled	Rifled	Rifled
Tube Size in. [mm] OD	0.375 [9.5]	0.375 [9.5]	0.375 [9.5]	0.375 [9.5]
Face Area sq. ft. [sq. m]	10.44 [0.97]	12.65 [1.18]	12.65 [1.18]	12.65 [1.18]
Rows / FPI [FPcm]	1 / 20 [8]	1 / 20 [8]	1 / 20 [8]	1 / 20 [8]
Refrigerant Control	TX Valves	TX Valves	TX Valves	TX Valves
Indoor Coil—Fin Type	Louvered	Louvered	Louvered	Louvered
Tube Type	Rifled	Rifled	Rifled	Rifled
Tube Size in. [mm]	0.375 [9.5]	0.375 [9.5]	0.375 [9.5]	0.375 [9.5]
Face Area sq. ft. [sq. m]	4.33 [0.4]	4.33 [0.4]	4.33 [0.4]	4.33 [0.4]
Rows / FPI [FPcm]	2 / 15 [6]	3 / 13 [5]	3 / 13 [5]	3 / 13 [5]
Refrigerant Control	TX Valves	TX Valves	TX Valves	TX Valves
Drain Connection No./Size in. [mm]	1/1 [25.4]	1/1 [25.4]	1/1 [25.4]	1/1 [25.4]
Outdoor Fan—Type	Propeller	Propeller	Propeller	Propeller
No. Used/Diameter in. [mm]	1/24 [609.6]	1/24 [609.6]	1/24 [609.6]	1/24 [609.6]
Drive Type/No. Speeds	Direct/1	Direct/1	Direct/1	Direct/1
CFM [L/s]	3200 [1510]	3200 [1510]	3200 [1510]	3200 [1510]
No. Motors/HP	1 at 1/3 HP	1 at 1/3 HP	1 at 1/3 HP	1 at 1/3 HP
Motor RPM	825	825	825	825
Indoor Fan—Type	FC Centrifugal	FC Centrifugal	FC Centrifugal	FC Centrifugal
No. Used/Diameter in. [mm]	1/10x9 [254x228.6]	1/10x9 [254x228.6]	1/10x9 [254x228.6]	1/10x9 [254x228.6]
Drive Type/No. Speeds	Direct/2	Direct/2	Direct/2	Direct/2
No. Motors	1	1	1	1
Motor HP	1/4	1/3	1/2	1/2
Motor RPM	1033	1080	1050	1050
Motor Frame Size	48	48	48	48
Filter—Type	Field Supplied	Field Supplied	Field Supplied	Field Supplied
Furnished	No	No	No	No
(No.) Size Recommended in. [mm]	(1)1x20x16 [25x508x406]	(1)1x20x20 [25x508x508]	(1)1x24x24 [25x610x610]	(1)1x24x24 [25x610x610]
Refrigerant Charge Oz. [g]	90 [2552]	93 [2637]	93 [2637]	93 [2637]
Weights				
Net Weight lbs. [kg]	308 [140]	331 [150]	356 [161]	356 [161]
Ship Weight lbs. [kg]	332 [151]	355 [161]	380 [172]	380 [172]

See Page 15 for Notes.

[] Designates Metric Conversions



NOMINAL SIZES 2-5 TONS [7-17.6 kW]

Model RQNM- Series	A042CK	A042JK	A048CK	A048JK
Cooling Performance¹				CONTINUED →
Gross Cooling Capacity Btu [kW]	43,500 [12.75]	43,500 [12.75]	49,500 [14.5]	49,500 [14.5]
EER/SEER ²	11/13	11/13	11/13	11/13
Nominal CFM/ARI Rated CFM [L/s]	1400/1450 [661/684]	1400/1450 [661/684]	1600/1550 [755/731]	1600/1550 [755/731]
ARI Net Cooling Capacity Btu [kW]	42,000 [12.31]	42,000 [12.31]	47,500 [13.92]	47,500 [13.92]
Net Sensible Capacity Btu [kW]	30,000 [8.79]	30,000 [8.79]	35,900 [10.52]	35,900 [10.52]
Net Latent Capacity Btu [kW]	12,000 [3.52]	12,000 [3.52]	11,600 [3.4]	11,600 [3.4]
Net System Power kW	3.82	3.82	4.32	4.32
Heating Performance (Heat Pumps)³				
Heating Input Btu [kW] Rating	39,500 [11.57]	39,500 [11.57]	43,000 [12.6]	43,000 [12.6]
System Power KW/COP	3.56/3.24	3.56/3.24	3.92/3.44	3.92/3.44
Low Temp. Btuh [kW] Rating	22,800 [6.68]	22,800 [6.68]	25,600 [7.5]	25,600 [7.5]
System Power KW/COP	3.25/2.06	3.25/2.06	3.56/2.14	3.56/2.14
HSPF (Btu/Watts-hr)	7.7	7.7	7.7	7.7
Compressor				
No./Type	1/Scroll	1/Scroll	1/Scroll	1/Scroll
Outdoor Sound Rating (dB)⁴	78	78	78	78
Outdoor Coil—Fin Type	Louvered	Louvered	Louvered	Louvered
Tube Type	Rifled	Rifled	Rifled	Rifled
Tube Size in. [mm] OD	0.375 [9.5]	0.375 [9.5]	0.375 [9.5]	0.375 [9.5]
Face Area sq. ft. [sq. m]	16.54 [1.54]	16.54 [1.54]	16.54 [1.54]	16.54 [1.54]
Rows / FPI [FPcm]	1 / 22 [9]	1 / 22 [9]	1 / 22 [9]	1 / 22 [9]
Refrigerant Control	TX Valves	TX Valves	TX Valves	TX Valves
Indoor Coil—Fin Type	Louvered	Louvered	Louvered	Louvered
Tube Type	Rifled	Rifled	Rifled	Rifled
Tube Size in. [mm]	0.375 [9.5]	0.375 [9.5]	0.375 [9.5]	0.375 [9.5]
Face Area sq. ft. [sq. m]	5.78 [0.54]	5.78 [0.54]	5.78 [0.54]	5.78 [0.54]
Rows / FPI [FPcm]	3 / 13 [5]	3 / 13 [5]	3 / 13 [5]	3 / 13 [5]
Refrigerant Control	TX Valves	TX Valves	TX Valves	TX Valves
Drain Connection No./Size in. [mm]	1/1 [25.4]	1/1 [25.4]	1/1 [25.4]	1/1 [25.4]
Outdoor Fan—Type	Propeller	Propeller	Propeller	Propeller
No. Used/Diameter in. [mm]	1/24 [609.6]	1/24 [609.6]	1/24 [609.6]	1/24 [609.6]
Drive Type/No. Speeds	Direct/1	Direct/1	Direct/1	Direct/1
CFM [L/s]	4200 [1982]	4200 [1982]	4200 [1982]	4200 [1982]
No. Motors/HP	1 at 1/3 HP	1 at 1/3 HP	1 at 1/3 HP	1 at 1/3 HP
Motor RPM	1075	1075	1075	1075
Indoor Fan—Type	FC Centrifugal	FC Centrifugal	FC Centrifugal	FC Centrifugal
No. Used/Diameter in. [mm]	1/11x9 [279.4x228.6]	1/11x9 [279.4x228.6]	1/11x9 [279.4x228.6]	1/11x9 [279.4x228.6]
Drive Type/No. Speeds	Direct/2	Direct/2	Direct/2	Direct/2
No. Motors	1	1	1	1
Motor HP	1/2	1/2	3/4	3/4
Motor RPM	1075	1075	1075	1075
Motor Frame Size	48	48	48	48
Filter—Type	Field Supplied	Field Supplied	Field Supplied	Field Supplied
Furnished	No	No	No	No
(No.) Size Recommended in. [mm]	(1)1x24x24 [25x610x610]	(1)1x24x24 [25x610x610]	(1)1x24x24 [25x610x610]	(1)1x24x24 [25x610x610]
Refrigerant Charge Oz. [g]	128 [3629]	128 [3629]	120 [3402]	120 [3402]
Weights				
Net Weight lbs. [kg]	408 [185]	408 [185]	429 [195]	429 [195]
Ship Weight lbs. [kg]	434 [197]	434 [197]	455 [206]	455 [206]

See Page 15 for Notes.

[] Designates Metric Conversions



NOMINAL SIZES 2-5 TONS [7-17.6 kW]

Model RQNM- Series	A060CK	A060JK
Cooling Performance¹		
Gross Cooling Capacity Btu [kW]	62,000 [18.17]	62,000 [18.17]
EER/SEER ²	11/13	11/13
Nominal CFM/ARI Rated CFM [L/s]	2000/1900 [944/897]	2000/1900 [944/897]
ARI Net Cooling Capacity Btu [kW]	59,000 [17.29]	59,000 [17.29]
Net Sensible Capacity Btu [kW]	44,500 [13.04]	44,500 [13.04]
Net Latent Capacity Btu [kW]	14,500 [4.25]	14,500 [4.25]
Net System Power kW	5.36	5.36
Heating Performance (Heat Pumps)³		
Heating Input Btu [kW] Rating	61,000 [17.87]	61,000 [17.87]
System Power KW/COP	5.15/3.52	5.15/3.52
Low Temp. Btuh [kW] Rating	34,400 [10.08]	34,400 [10.08]
System Power KW/COP	4.64/2.18	4.64/2.18
HSPF (Btu/Watts-hr)	7.7	7.7
Compressor		
No./Type	1/Scroll	1/Scroll
Outdoor Sound Rating (dB)⁴		
	78	78
Outdoor Coil—Fin Type		
Tube Type	Louvered	Louvered
Tube Size in. [mm] OD	Rifled	Rifled
Tube Size in. [mm] OD	0.375 [9.5]	0.375 [9.5]
Face Area sq. ft. [sq. m]	16.54 [1.54]	16.54 [1.54]
Rows / FPI [FPcm]	2 / 18 [7]	2 / 18 [7]
Refrigerant Control	TX Valves	TX Valves
Indoor Coil—Fin Type		
Tube Type	Louvered	Louvered
Tube Type	Rifled	Rifled
Tube Size in. [mm]	0.375 [9.5]	0.375 [9.5]
Face Area sq. ft. [sq. m]	5.78 [0.54]	5.78 [0.54]
Rows / FPI [FPcm]	4 / 13 [5]	4 / 13 [5]
Refrigerant Control	TX Valves	TX Valves
Drain Connection No./Size in. [mm]	1/1 [25.4]	1/1 [25.4]
Outdoor Fan—Type		
	Propeller	Propeller
No. Used/Diameter in. [mm]	1/24 [609.6]	1/24 [609.6]
Drive Type/No. Speeds	Direct/1	Direct/1
CFM [L/s]	4000 [1888]	4000 [1888]
No. Motors/HP	1 at 1/3 HP	1 at 1/3 HP
Motor RPM	1075	1075
Indoor Fan—Type		
	FC Centrifugal	FC Centrifugal
No. Used/Diameter in. [mm]	1/11x9 [279.4x228.6]	1/11x9 [279.4x228.6]
Drive Type/No. Speeds	Direct/2	Direct/2
No. Motors	1	1
Motor HP	3/4	3/4
Motor RPM	1075	1075
Motor Frame Size	48	48
Filter—Type		
	Field Supplied	Field Supplied
Furnished	No	No
(No.) Size Recommended in. [mm]	(1)1x24x24 [25x610x610]	(1)1x24x24 [25x610x610]
Refrigerant Charge Oz. [g]		
	193 [5472]	193 [5472]
Weights		
Net Weight lbs. [kg]	481 [218]	481 [218]
Ship Weight lbs. [kg]	507 [230]	507 [230]

See Page 15 for Notes.

[] Designates Metric Conversions



NOMINAL SIZES 2-5 TONS [7-17.6 kW]

Model RQPM- Series	A024JK	A030JK	A036CK	A036JK
Cooling Performance¹				CONTINUED →
Gross Cooling Capacity Btu [kW]	24,000 [7.03]	29,400 [8.61]	36,000 [10.55]	36,000 [10.55]
EER/SEER ²	12/14	12.05/14	11.6/14	11.6/14
Nominal CFM/ARI Rated CFM [L/s]	800/800 [378/378]	1000/1000 [472/472]	1200/1200 [566/566]	1200/1200 [566/566]
ARI Net Cooling Capacity Btu [kW]	23,600 [6.91]	29,000 [8.5]	35,400 [10.37]	35,400 [10.37]
Net Sensible Capacity Btu [kW]	18,400 [5.39]	23,000 [6.74]	27,600 [8.09]	27,600 [8.09]
Net Latent Capacity Btu [kW]	5,200 [1.52]	6,000 [1.76]	7,800 [2.29]	7,800 [2.29]
Net System Power kW	1.97	2.41	3.05	3.05
Heating Performance (Heat Pumps)³				
Heating Input Btu [kW] Rating	23,200 [6.8]	28,000 [8.2]	34,200 [10.02]	34,200 [10.02]
System Power KW/COP	1.93/3.5	2.27/3.62	2.78/3.6	2.78/3.6
Low Temp. Btuh [kW] Rating	13,200 [3.87]	15,200 [4.45]	19,000 [5.57]	19,000 [5.57]
System Power KW/COP	1.71/2.26	2.01/2.22	2.48/2.24	2.48/2.24
HSPF (Btu/Watts-hr)	8.0	8.0	8.0	8.0
Compressor				
No./Type	1/Scroll	1/Scroll	1/Scroll	1/Scroll
Outdoor Sound Rating (dB)⁴	76	76	76	76
Outdoor Coil—Fin Type	Louvered	Louvered	Louvered	Louvered
Tube Type	Rifled	Rifled	Rifled	Rifled
Tube Size in. [mm] OD	0.375 [9.5]	0.375 [9.5]	0.375 [9.5]	0.375 [9.5]
Face Area sq. ft. [sq. m]	10.44 [0.97]	12.65 [1.18]	12.65 [1.18]	12.65 [1.18]
Rows / FPI [FPcm]	1 / 20 [8]	1 / 20 [8]	1 / 20 [8]	1 / 20 [8]
Refrigerant Control	TX Valves	TX Valves	TX Valves	TX Valves
Indoor Coil—Fin Type	Louvered	Louvered	Louvered	Louvered
Tube Type	Rifled	Rifled	Rifled	Rifled
Tube Size in. [mm]	0.375 [9.5]	0.375 [9.5]	0.375 [9.5]	0.375 [9.5]
Face Area sq. ft. [sq. m]	4.33 [0.4]	4.33 [0.4]	4.33 [0.4]	4.33 [0.4]
Rows / FPI [FPcm]	2 / 15 [6]	3 / 13 [5]	3 / 13 [5]	3 / 13 [5]
Refrigerant Control	TX Valves	TX Valves	TX Valves	TX Valves
Drain Connection No./Size in. [mm]	1/1 [25.4]	1/1 [25.4]	1/1 [25.4]	1/1 [25.4]
Outdoor Fan—Type	Propeller	Propeller	Propeller	Propeller
No. Used/Diameter in. [mm]	1/24 [609.6]	1/24 [609.6]	1/24 [609.6]	1/24 [609.6]
Drive Type/No. Speeds	Direct/1	Direct/1	Direct/1	Direct/1
CFM [L/s]	3200 [1510]	3200 [1510]	3200 [1510]	3200 [1510]
No. Motors/HP	1 at 1/3 HP	1 at 1/3 HP	1 at 1/3 HP	1 at 1/3 HP
Motor RPM	825	825	825	825
Indoor Fan—Type	FC Centrifugal	FC Centrifugal	FC Centrifugal	FC Centrifugal
No. Used/Diameter in. [mm]	1/10x9 [254x228.6]	1/10x9 [254x228.6]	1/10x9 [254x228.6]	1/10x9 [254x228.6]
Drive Type/No. Speeds	Direct/2	Direct/2	Direct/2	Direct/2
No. Motors	1	1	1	1
Motor HP	1/2	1/2	1/2	1/2
Motor RPM	1050	1050	1050	1050
Motor Frame Size	48	48	48	48
Filter—Type	Field Supplied	Field Supplied	Field Supplied	Field Supplied
Furnished	No	No	No	No
(No.) Size Recommended in. [mm]	(1)1x20x16 [25x508x406]	(1)1x20x20 [25x508x508]	(1)1x24x24 [25x610x610]	(1)1x24x24 [25x610x610]
Refrigerant Charge Oz. [g]	90 [2552]	93 [2637]	93 [2637]	93 [2637]
Weights				
Net Weight lbs. [kg]	308 [140]	331 [150]	356 [161]	356 [161]
Ship Weight lbs. [kg]	332 [151]	355 [161]	380 [172]	380 [172]

See Page 15 for Notes.

[] Designates Metric Conversions



NOMINAL SIZES 2-5 TONS [7-17.6 kW]

Model RQPM- Series	A037CK	A037JK	A042CK	A042JK
Cooling Performance¹				CONTINUED →
Gross Cooling Capacity Btu [kW]	36,000 [10.55]	36,000 [10.55]	44,000 [12.89]	44,000 [12.89]
EER/SEER ²	12/14	12/14	11.85/14	11.85/14
Nominal CFM/ARI Rated CFM [L/s]	1200/1200 [566/566]	1200/1200 [566/566]	1400/1450 [661/684]	1400/1450 [661/684]
ARI Net Cooling Capacity Btu [kW]	35,400 [10.37]	35,400 [10.37]	43,000 [12.6]	43,000 [12.6]
Net Sensible Capacity Btu [kW]	27,600 [8.09]	27,600 [8.09]	31,800 [9.32]	31,800 [9.32]
Net Latent Capacity Btu [kW]	7,800 [2.29]	7,800 [2.29]	11,200 [3.28]	11,200 [3.28]
Net System Power kW	3.05	3.05	3.63	3.63
Heating Performance (Heat Pumps)³				
Heating Input Btu [kW] Rating	34,200 [10.02]	34,200 [10.02]	38,500 [11.28]	38,500 [11.28]
System Power KW/COP	2.78/3.6	2.78/3.6	3.31/3.4	3.31/3.4
Low Temp. Btuh [kW] Rating	19,000 [5.57]	19,000 [5.57]	21,800 [6.39]	21,800 [6.39]
System Power KW/COP	2.48/2.24	2.48/2.24	3/2.06	3/2.06
HSPF (Btu/Watts-hr)	8	8	8.1	8.0
Compressor				
No./Type	1/Scroll	1/Scroll	1/Scroll	1/Scroll
Outdoor Sound Rating (dB)⁴	76	76	78	78
Outdoor Coil—Fin Type	Louvered	Louvered	Louvered	Louvered
Tube Type	Rifled	Rifled	Rifled	Rifled
Tube Size in. [mm] OD	0.375 [9.5]	0.375 [9.5]	0.375 [9.5]	0.375 [9.5]
Face Area sq. ft. [sq. m]	12.65 [1.18]	12.65 [1.18]	16.54 [1.54]	16.54 [1.54]
Rows / FPI [FPcm]	1 / 20 [8]	1 / 20 [8]	1 / 22 [9]	1 / 22 [9]
Refrigerant Control	TX Valves	TX Valves	TX Valves	TX Valves
Indoor Coil—Fin Type	Louvered	Louvered	Louvered	Louvered
Tube Type	Rifled	Rifled	Rifled	Rifled
Tube Size in. [mm]	0.375 [9.5]	0.375 [9.5]	0.375 [9.5]	0.375 [9.5]
Face Area sq. ft. [sq. m]	4.33 [0.4]	4.33 [0.4]	5.78 [0.54]	5.78 [0.54]
Rows / FPI [FPcm]	3 / 13 [5]	3 / 13 [5]	3 / 13 [5]	3 / 13 [5]
Refrigerant Control	TX Valves	TX Valves	TX Valves	TX Valves
Drain Connection No./Size in. [mm]	1/1 [25.4]	1/1 [25.4]	1/1 [25.4]	1/1 [25.4]
Outdoor Fan—Type	Propeller	Propeller	Propeller	Propeller
No. Used/Diameter in. [mm]	1/24 [609.6]	1/24 [609.6]	1/24 [609.6]	1/24 [609.6]
Drive Type/No. Speeds	Direct/1	Direct/1	Direct/1	Direct/1
CFM [L/s]	3200 [1510]	3200 [1510]	4200 [1982]	4200 [1982]
No. Motors/HP	1 at 1/3 HP	1 at 1/3 HP	1 at 1/3 HP	1 at 1/3 HP
Motor RPM	850	850	1075	1075
Indoor Fan—Type	FC Centrifugal	FC Centrifugal	FC Centrifugal	FC Centrifugal
No. Used/Diameter in. [mm]	1/10x9 [254x229]	1/10x9 [254x229]	1/11x9 [279.4x228.6]	1/11x9 [279.4x228.6]
Drive Type/No. Speeds	Direct/2	Direct/2	Direct/2	Direct/2
No. Motors	1	1	1	1
Motor HP	1/2	1/2	3/4	3/4
Motor RPM	1050	1050	1050	1050
Motor Frame Size	48	48	48	48
Filter—Type	Field Supplied	Field Supplied	Field Supplied	Field Supplied
Furnished	No	No	No	No
(No.) Size Recommended in. [mm]	(1)1x24x24 [25x610x610]	(1)1x24x24 [25x610x610]	(1)1x24x24 [25x610x610]	(1)1x24x24 [25x610x610]
Refrigerant Charge Oz. [g]	93 [2637]	93 [2637]	128 [3629]	128 [3629]
Weights				
Net Weight lbs. [kg]	356 [161]	356 [161]	408 [185]	408 [185]
Ship Weight lbs. [kg]	380 [172]	380 [172]	434 [197]	434 [197]

See Page 15 for Notes.

[] Designates Metric Conversions



NOMINAL SIZES 2-5 TONS [7-17.6 kW]

Model RQPM- Series	A048CK	A048JK	A049CK	A049JK
Cooling Performance¹				CONTINUED →
Gross Cooling Capacity Btu [kW]	49,000 [14.36]	49,000 [14.36]	49,000 [14.36]	49,000 [14.36]
EER/SEER ²	11.8/14	11.8/14	12/14	12/14
Nominal CFM/ARI Rated CFM [L/s]	1600/1550 [755/731]	1600/1550 [755/731]	1600/1550 [755/731]	1600/1550 [755/731]
ARI Net Cooling Capacity Btu [kW]	48,000 [14.06]	48,000 [14.06]	48,000 [14.06]	48,000 [14.06]
Net Sensible Capacity Btu [kW]	36,800 [10.78]	36,800 [10.78]	36,800 [10.78]	36,800 [10.78]
Net Latent Capacity Btu [kW]	11,200 [3.28]	11,200 [3.28]	11,200 [3.28]	11,200 [3.28]
Net System Power kW	4.07	4.07	4	4
Heating Performance (Heat Pumps)³				
Heating Input Btu [kW] Rating	42,000 [12.31]	42,000 [12.31]	42,000 [12.31]	42,000 [12.31]
System Power KW/COP	3.59/3.66	3.59/3.66	3.59/3.66	3.59/3.66
Low Temp. Btuh [kW] Rating	25,400 [7.44]	25,400 [7.44]	25,400 [7.44]	25,400 [7.44]
System Power KW/COP	3.22/2.3	3.22/2.3	3.22/2.3	3.22/2.3
HSPF (Btu/Watts-hr)	8.0	8.0	8	8
Compressor				
No./Type	1/Scroll	1/Scroll	1/Scroll	1/Scroll
Outdoor Sound Rating (dB)⁴	78	78	78	78
Outdoor Coil—Fin Type	Louvered	Louvered	Louvered	Louvered
Tube Type	Rifled	Rifled	Rifled	Rifled
Tube Size in. [mm] OD	0.375 [9.5]	0.375 [9.5]	0.375 [9.5]	0.375 [9.5]
Face Area sq. ft. [sq. m]	16.54 [1.54]	16.54 [1.54]	16.54 [1.54]	16.54 [1.54]
Rows / FPI [FPcm]	1 / 22 [9]	1 / 22 [9]	1 / 22 [9]	1 / 22 [9]
Refrigerant Control	TX Valves	TX Valves	TX Valves	TX Valves
Indoor Coil—Fin Type	Louvered	Louvered	Louvered	Louvered
Tube Type	Rifled	Rifled	Rifled	Rifled
Tube Size in. [mm]	0.375 [9.5]	0.375 [9.5]	0.375 [9.5]	0.375 [9.5]
Face Area sq. ft. [sq. m]	5.78 [0.54]	5.78 [0.54]	5.78 [0.54]	5.78 [0.54]
Rows / FPI [FPcm]	3 / 13 [5]	3 / 13 [5]	3 / 13 [5]	3 / 13 [5]
Refrigerant Control	TX Valves	TX Valves	TX Valves	TX Valves
Drain Connection No./Size in. [mm]	1/1 [25.4]	1/1 [25.4]	1/1 [25.4]	1/1 [25.4]
Outdoor Fan—Type	Propeller	Propeller	Propeller	Propeller
No. Used/Diameter in. [mm]	1/24 [609.6]	1/24 [609.6]	1/24 [609.6]	1/24 [609.6]
Drive Type/No. Speeds	Direct/1	Direct/1	Direct/1	Direct/1
CFM [L/s]	4200 [1982]	4200 [1982]	4200 [1982]	4200 [1982]
No. Motors/HP	1 at 1/3 HP	1 at 1/3 HP	1 at 1/3 HP	1 at 1/3 HP
Motor RPM	1075	1075	908	908
Indoor Fan—Type	FC Centrifugal	FC Centrifugal	FC Centrifugal	FC Centrifugal
No. Used/Diameter in. [mm]	1/11x9 [279.4x228.6]	1/11x9 [279.4x228.6]	1/11x9 [279x229]	1/11x9 [279x229]
Drive Type/No. Speeds	Direct/2	Direct/2	Direct/2	Direct/2
No. Motors	1	1	1	1
Motor HP	3/4	3/4	3/4	3/4
Motor RPM	1050	1050	1050	1050
Motor Frame Size	48	48	48	48
Filter—Type	Field Supplied	Field Supplied	Field Supplied	Field Supplied
Furnished	No	No	No	No
(No.) Size Recommended in. [mm]	(1)1x24x24 [25x610x610]	(1)1x24x24 [25x610x610]	(1)1x24x24 [25x610x610]	(1)1x24x24 [25x610x610]
Refrigerant Charge Oz. [g]	120 [3402]	120 [3402]	120 [3402]	120 [3402]
Weights				
Net Weight lbs. [kg]	429 [195]	429 [195]	429 [195]	429 [195]
Ship Weight lbs. [kg]	455 [206]	455 [206]	455 [206]	455 [206]

See Page 15 for Notes.

[] Designates Metric Conversions



NOMINAL SIZES 2-5 TONS [7-17.6 kW]

Model RQPM- Series	A060CK	A060JK
Cooling Performance¹		
Gross Cooling Capacity Btu [kW]	61,000 [17.87]	61,000 [17.87]
EER/SEER ²	12.0/14	12.0/14
Nominal CFM/ARI Rated CFM [L/s]	2000/1900 [944/897]	2000/1900 [944/897]
ARI Net Cooling Capacity Btu [kW]	59,500 [17.43]	59,500 [17.43]
Net Sensible Capacity Btu [kW]	45,300 [13.27]	45,300 [13.27]
Net Latent Capacity Btu [kW]	14,200 [4.16]	14,200 [4.16]
Net System Power kW	5.00	5.00
Heating Performance (Heat Pumps)³		
Heating Input Btu [kW] Rating	59,500 [17.43]	59,500 [17.43]
System Power KW/COP	4.74/3.72	4.74/3.72
Low Temp. Btuh [kW] Rating	36,600 [10.72]	36,600 [10.72]
System Power KW/COP	4.26/2.54	4.26/2.54
HSPF (Btu/Watts-hr)	8	8
Compressor		
No./Type	1/Scroll	1/Scroll
Outdoor Sound Rating (dB)⁴		
	78	78
Outdoor Coil—Fin Type		
Tube Type	Louvered	Louvered
Tube Size in. [mm] OD	Rifled	Rifled
Tube Size in. [mm] OD	0.375 [9.5]	0.375 [9.5]
Face Area sq. ft. [sq. m]	16.54 [1.54]	16.54 [1.54]
Rows / FPI [FPcm]	2 / 18 [7]	2 / 18 [7]
Refrigerant Control	TX Valves	TX Valves
Indoor Coil—Fin Type		
Tube Type	Louvered	Louvered
Tube Type	Rifled	Rifled
Tube Size in. [mm]	0.375 [9.5]	0.375 [9.5]
Face Area sq. ft. [sq. m]	5.78 [0.54]	5.78 [0.54]
Rows / FPI [FPcm]	4 / 13 [5]	4 / 13 [5]
Refrigerant Control	TX Valves	TX Valves
Drain Connection No./Size in. [mm]	1/1 [25.4]	1/1 [25.4]
Outdoor Fan—Type		
	Propeller	Propeller
No. Used/Diameter in. [mm]	1/24 [609.6]	1/24 [609.6]
Drive Type/No. Speeds	Direct/1	Direct/1
CFM [L/s]	4000 [1888]	4000 [1888]
No. Motors/HP	1 at 1/3 HP	1 at 1/3 HP
Motor RPM	1075	1075
Indoor Fan—Type		
	FC Centrifugal	FC Centrifugal
No. Used/Diameter in. [mm]	1/11x9 [279.4x228.6]	1/11x9 [279.4x228.6]
Drive Type/No. Speeds	Direct/2	Direct/2
No. Motors	1	1
Motor HP	1	1
Motor RPM	1050	1050
Motor Frame Size	48	48
Filter—Type		
	Field Supplied	Field Supplied
Furnished	No	No
(No.) Size Recommended in. [mm]	(1)1x24x24 [25x610x610]	(1)1x24x24 [25x610x610]
Refrigerant Charge Oz. [g]		
	193 [5472]	193 [5472]
Weights		
Net Weight lbs. [kg]	481 [218]	481 [218]
Ship Weight lbs. [kg]	507 [230]	507 [230]

See Page 15 for Notes.

[] Designates Metric Conversions



NOTES:

1. Cooling Performance is rated at 95° F ambient, 80° F entering dry bulb, 67° F entering wet bulb. Gross capacity does not include the effect of fan motor heat. ARI capacity is net and includes the effect of fan motor heat. Units are suitable for operation to $\pm 20\%$ of nominal cfm. Units are certified in accordance with the Unitary Air Conditioner Equipment certification program, which is based on ARI Standard 210/240 or 360.
2. EER and/or SEER are rated at ARI conditions and in accordance with DOE test procedures.
3. Heating Performance is rated at 47° F ambient, 70° F entering dry bulb for High Temp rating and 17° ambient, 70° F entering dry bulb for Low Temp rating. Performance ratings do include the effect of fan motor heat.
4. Outdoor Sound Rating shown is tested in accordance with ARI Standard 270.



GROSS SYSTEMS PERFORMANCE DATA—RQNM-A024

		ENTERING INDOOR AIR @ 80°F [26.7°C] dbE ①									
wbE		71°F [21.7°C]			67°F [19.4°C]			63°F [17.2°C]			
CFM [L/s]		960 [453]	800 [378]	640 [302]	960 [453]	800 [378]	640 [302]	960 [453]	800 [378]	640 [302]	
DR ①		.13	.09	.05	.13	.09	.05	.13	.09	.05	
OUTDOOR DRY BULB TEMPERATURE °F [°C]	75 [23.9]	Total BTUH [kW] Sens BTUH [kW] Power	30.8 [9.03] 18.7 [5.48] 1.7	29.7 [8.70] 17.1 [5.01] 1.6	28.7 [8.41] 15.5 [4.54] 1.6	29.0 [8.50] 22.5 [6.59] 1.7	27.9 [8.18] 20.6 [6.04] 1.6	26.9 [7.88] 18.7 [5.48] 1.6	27.7 [8.12] 25.9 [7.59] 1.7	26.7 [7.83] 23.7 [6.95] 1.7	25.7 [7.53] 21.5 [6.30] 1.6
	80 [26.7]	Total BTUH [kW] Sens BTUH [kW] Power	29.9 [8.76] 18.4 [5.39] 1.7	28.8 [8.44] 16.8 [4.92] 1.7	27.8 [8.15] 15.3 [4.48] 1.7	28.0 [8.21] 22.2 [6.51] 1.7	27.0 [7.91] 20.3 [5.95] 1.7	26.1 [7.65] 18.4 [5.39] 1.7	26.7 [7.83] 25.7 [7.53] 1.7	25.8 [7.56] 23.5 [6.89] 1.7	24.8 [7.27] 21.3 [6.24] 1.7
	85 [29.4]	Total BTUH [kW] Sens BTUH [kW] Power	29.0 [8.50] 18.0 [5.28] 1.8	28.0 [8.21] 16.5 [4.84] 1.8	27.0 [7.91] 15.0 [4.40] 1.7	27.1 [7.94] 21.8 [6.39] 1.8	26.2 [7.68] 20.0 [5.86] 1.8	25.2 [7.39] 18.1 [5.30] 1.7	25.8 [7.56] 25.3 [7.41] 1.8	24.9 [7.30] 23.1 [6.77] 1.8	24.0 [7.03] 21.0 [6.15] 1.7
	90 [32.2]	Total BTUH [kW] Sens BTUH [kW] Power	28.1 [8.24] 17.6 [5.16] 1.9	27.1 [7.94] 16.1 [4.72] 1.8	26.2 [7.68] 14.6 [4.28] 1.8	26.3 [7.71] 21.4 [6.27] 1.8	25.4 [7.44] 19.6 [5.74] 1.8	24.4 [7.15] 17.7 [5.19] 1.8	25.0 [7.33] 24.8 [7.27] 1.9	24.1 [7.06] 22.7 [6.65] 1.8	23.2 [6.80] 20.6 [6.04] 1.8
	95 [35]	Total BTUH [kW] Sens BTUH [kW] Power	27.3 [8.00] 17.1 [5.01] 1.9	26.3 [7.71] 15.7 [4.60] 1.9	25.4 [7.44] 14.2 [4.16] 1.9	25.4 [7.44] 20.9 [6.13] 1.9	24.5 [7.18] 19.1 [5.60] 1.9	23.6 [6.92] 17.3 [5.07] 1.8	24.1 [7.06] 24.1 [7.06] 1.9	23.3 [6.83] 22.3 [6.54] 1.9	22.4 [6.56] 20.2 [5.92] 1.9
	100 [37.8]	Total BTUH [kW] Sens BTUH [kW] Power	26.4 [7.74] 16.6 [4.86] 2.0	25.5 [7.47] 15.2 [4.45] 2.0	24.5 [7.18] 13.8 [4.04] 1.9	24.5 [7.18] 20.4 [5.98] 2.0	23.7 [6.95] 18.6 [5.45] 1.9	22.8 [6.68] 16.9 [4.95] 1.9	23.2 [6.80] 23.2 [6.80] 2.0	22.4 [6.56] 21.8 [6.39] 2.0	21.6 [6.33] 19.8 [5.80] 1.9
	105 [40.6]	Total BTUH [kW] Sens BTUH [kW] Power	25.4 [7.44] 16.0 [4.69] 2.0	24.5 [7.18] 14.7 [4.31] 2.0	23.6 [6.92] 13.3 [3.90] 2.0	23.6 [6.92] 19.8 [5.80] 2.0	22.7 [6.65] 18.1 [5.30] 2.0	21.9 [6.42] 16.4 [4.81] 2.0	22.3 [6.54] 22.3 [6.54] 2.0	21.5 [6.30] 21.3 [6.24] 2.0	20.7 [6.07] 19.3 [5.66] 2.0
	110 [43.3]	Total BTUH [kW] Sens BTUH [kW] Power	24.4 [7.15] 15.5 [4.54] 2.1	23.5 [6.89] 14.1 [4.13] 2.1	22.7 [6.65] 12.8 [3.75] 2.0	22.5 [6.59] 19.2 [5.63] 2.1	21.7 [6.36] 17.6 [5.16] 2.1	20.9 [6.13] 16.0 [4.69] 2.0	21.2 [6.21] 21.2 [6.21] 2.1	20.5 [6.01] 20.5 [6.01] 2.1	19.7 [5.77] 18.8 [5.51] 2.0
	115 [46.1]	Total BTUH [kW] Sens BTUH [kW] Power	23.2 [6.80] 14.9 [4.37] 2.2	22.4 [6.56] 13.6 [3.99] 2.1	21.6 [6.33] 12.3 [3.60] 2.1	21.3 [6.24] 18.6 [5.45] 2.2	20.6 [6.04] 17.0 [4.98] 2.1	19.8 [5.80] 15.5 [4.54] 2.1	20.0 [5.86] 20.0 [5.86] 2.2	19.3 [5.66] 19.3 [5.66] 2.1	18.6 [5.45] 18.3 [5.36] 2.1

GROSS SYSTEMS PERFORMANCE DATA—RQNM-A030

		ENTERING INDOOR AIR @ 80°F [26.7°C] dbE ①									
wbE		71°F [21.7°C]			67°F [19.4°C]			63°F [17.2°C]			
CFM [L/s]		1200 [566]	1000 [472]	800 [378]	1200 [566]	1000 [472]	800 [378]	1200 [566]	1000 [472]	800 [378]	
DR ①		.14	.10	.05	.14	.10	.05	.14	.10	.05	
OUTDOOR DRY BULB TEMPERATURE °F [°C]	75 [23.9]	Total BTUH [kW] Sens BTUH [kW] Power	38.7 [11.34] 23.4 [6.86] 1.9	37.3 [10.93] 21.4 [6.27] 1.8	36.0 [10.55] 19.4 [5.69] 1.8	35.6 [10.43] 27.7 [8.12] 1.9	34.3 [10.05] 25.3 [7.41] 1.8	33.1 [9.70] 22.9 [6.71] 1.8	33.9 [9.94] 31.3 [9.17] 1.9	32.7 [9.58] 28.7 [8.41] 1.8	31.5 [9.23] 26.0 [7.62] 1.8
	80 [26.7]	Total BTUH [kW] Sens BTUH [kW] Power	37.5 [10.99] 23.0 [6.74] 2.0	36.1 [10.58] 21.0 [6.15] 2.0	34.8 [10.20] 19.0 [5.57] 1.9	34.3 [10.05] 27.2 [7.97] 2.0	33.1 [9.70] 24.9 [7.30] 1.9	31.9 [9.35] 22.6 [6.62] 1.9	32.7 [9.58] 30.8 [9.03] 2.0	31.6 [9.26] 28.3 [8.29] 1.9	30.4 [8.91] 25.6 [7.50] 1.9
	85 [29.4]	Total BTUH [kW] Sens BTUH [kW] Power	36.3 [10.64] 22.5 [6.59] 2.1	35.0 [10.26] 20.6 [6.04] 2.1	33.7 [9.88] 18.6 [5.45] 2.0	33.2 [9.73] 26.7 [7.83] 2.1	32.0 [9.38] 24.5 [7.18] 2.1	30.9 [9.06] 22.2 [6.51] 2.0	31.6 [9.26] 30.5 [8.94] 2.1	30.5 [8.94] 27.8 [8.15] 2.0	29.3 [8.59] 25.2 [7.39] 2.0
	90 [32.2]	Total BTUH [kW] Sens BTUH [kW] Power	35.2 [10.32] 22.0 [6.45] 2.2	33.9 [9.94] 20.1 [5.89] 2.2	32.7 [9.58] 18.2 [5.33] 2.1	32.1 [9.41] 26.2 [7.68] 2.2	30.9 [9.06] 24.0 [7.03] 2.2	29.8 [8.73] 21.7 [6.36] 2.1	30.4 [8.91] 29.9 [8.76] 2.2	29.4 [8.62] 27.3 [8.00] 2.2	28.3 [8.29] 24.8 [7.27] 2.1
	95 [35]	Total BTUH [kW] Sens BTUH [kW] Power	34.1 [9.99] 21.4 [6.27] 2.3	32.9 [9.64] 19.6 [5.74] 2.3	31.7 [9.29] 17.8 [5.22] 2.2	31.0 [9.09] 25.7 [7.53] 2.3	29.9 [8.76] 23.5 [6.89] 2.3	28.8 [8.44] 21.3 [6.24] 2.2	29.3 [8.59] 29.2 [8.56] 2.3	28.3 [8.29] 26.8 [7.85] 2.3	27.3 [8.00] 24.3 [7.12] 2.2
	100 [37.8]	Total BTUH [kW] Sens BTUH [kW] Power	33.0 [9.67] 20.9 [6.13] 2.4	31.8 [9.32] 19.1 [5.60] 2.4	30.7 [9.00] 17.3 [5.07] 2.3	29.9 [8.76] 25.1 [7.36] 2.4	28.8 [8.44] 23.0 [6.74] 2.4	27.8 [8.15] 20.8 [6.10] 2.3	28.2 [8.26] 28.2 [8.26] 2.4	27.3 [8.00] 26.3 [7.71] 2.4	26.3 [7.71] 23.9 [7.00] 2.3
	105 [40.6]	Total BTUH [kW] Sens BTUH [kW] Power	31.9 [9.35] 20.3 [5.95] 2.5	30.7 [9.00] 18.6 [5.45] 2.5	29.6 [8.67] 16.8 [4.92] 2.4	28.8 [8.44] 24.5 [7.18] 2.5	27.7 [8.12] 22.5 [6.59] 2.5	26.7 [7.83] 20.4 [5.98] 2.4	27.1 [7.94] 27.1 [7.94] 2.5	26.2 [7.68] 25.8 [7.56] 2.5	25.2 [7.39] 23.4 [6.86] 2.4
	110 [43.3]	Total BTUH [kW] Sens BTUH [kW] Power	30.7 [9.00] 19.7 [5.77] 2.6	29.6 [8.67] 18.1 [5.30] 2.6	28.6 [8.38] 16.4 [4.81] 2.5	27.6 [8.09] 24.0 [7.03] 2.6	26.6 [7.80] 21.9 [6.42] 2.6	25.7 [7.53] 19.9 [5.83] 2.5	26.0 [7.62] 26.0 [7.62] 2.6	25.1 [7.36] 25.1 [7.36] 2.6	24.2 [7.09] 22.9 [6.71] 2.5
	115 [46.1]	Total BTUH [kW] Sens BTUH [kW] Power	29.5 [8.65] 19.2 [5.63] 2.7	28.5 [8.35] 17.6 [5.16] 2.7	27.5 [8.06] 15.9 [4.66] 2.7	26.4 [7.74] 23.5 [6.89] 2.7	25.5 [7.47] 21.5 [6.30] 2.7	24.6 [7.21] 19.5 [5.71] 2.7	24.8 [7.27] 24.8 [7.27] 2.7	23.9 [7.00] 23.9 [7.00] 2.7	23.1 [6.77] 22.5 [6.59] 2.6

DR —Depression ratio
dbE—Entering air dry bulb
wbE—Entering air wet bulb

Total —Total capacity x 1000 BTUH
Sens —Sensible capacity x 1000 BTUH
Power—KW input

NOTES: ① When the entering air dry bulb is other than 80°F [27°C], adjust the sensible capacity from the table by adding $[1.10 \times \text{CFM} \times (1 - \text{DR}) \times (\text{dbE} - 80)]$.

[] Designates Metric Conversions



SYSTEMS PERFORMANCE—RQNM- SERIES

GROSS SYSTEMS PERFORMANCE DATA—RQNM-A036

		ENTERING INDOOR AIR @ 80°F [26.7°C] dbE ①									
wbE		71°F [21.7°C]			67°F [19.4°C]			63°F [17.2°C]			
CFM [L/s]		1440 [680]	1200 [566]	960 [453]	1440 [680]	1200 [566]	960 [453]	1440 [680]	1200 [566]	960 [453]	
DR ①		.14	.11	.06	.14	.11	.06	.14	.11	.06	
OUTDOOR DRY BULB TEMPERATURE °F [°C]	75 [23.9]	Total BTUH [kW]	45.5 [13.33]	43.9 [12.87]	42.3 [12.40]	43.0 [12.60]	41.5 [12.16]	40.0 [11.72]	40.2 [11.78]	38.8 [11.37]	37.4 [10.96]
		Sens BTUH [kW]	28.2 [8.26]	25.8 [7.56]	23.4 [6.86]	33.7 [9.88]	30.8 [9.03]	27.9 [8.18]	37.8 [11.08]	34.6 [10.14]	31.4 [9.20]
		Power	2.4	2.3	2.3	2.3	2.3	2.3	2.3	2.3	2.3
	80 [26.7]	Total BTUH [kW]	44.4 [13.01]	42.8 [12.54]	41.3 [12.10]	41.9 [12.28]	40.5 [11.87]	39.0 [11.43]	39.1 [11.46]	37.8 [11.08]	36.4 [10.67]
		Sens BTUH [kW]	27.6 [8.09]	25.3 [7.41]	22.9 [6.71]	33.1 [9.70]	30.3 [8.88]	27.5 [8.06]	37.5 [10.99]	34.2 [10.02]	31.0 [9.09]
		Power	2.5	2.5	2.4	2.5	2.4	2.4	2.5	2.4	2.4
	85 [29.4]	Total BTUH [kW]	43.2 [12.66]	41.6 [12.19]	40.1 [11.75]	40.7 [11.93]	39.3 [11.52]	37.8 [11.08]	37.9 [11.11]	36.6 [10.73]	35.2 [10.32]
		Sens BTUH [kW]	27.0 [7.91]	24.7 [7.24]	22.4 [6.56]	32.5 [9.52]	29.7 [8.70]	26.9 [7.88]	36.8 [10.79]	33.6 [9.85]	30.4 [8.91]
		Power	2.6	2.6	2.6	2.6	2.6	2.5	2.6	2.5	2.5
	90 [32.2]	Total BTUH [kW]	41.8 [12.25]	40.3 [11.81]	38.9 [11.40]	39.3 [11.52]	38.0 [11.14]	36.6 [10.73]	36.5 [10.70]	35.2 [10.32]	34.0 [9.96]
Sens BTUH [kW]		26.3 [7.71]	24.0 [7.03]	21.8 [6.39]	31.8 [9.32]	29.1 [8.53]	26.3 [7.71]	35.9 [10.52]	32.9 [9.64]	29.8 [8.73]	
Power		2.8	2.7	2.7	2.7	2.7	2.6	2.7	2.7	2.6	
95 [35]	Total BTUH [kW]	40.3 [11.81]	38.9 [11.40]	37.5 [10.99]	37.9 [11.11]	36.6 [10.73]	35.2 [10.32]	35.1 [10.29]	33.8 [9.91]	32.6 [9.55]	
	Sens BTUH [kW]	25.5 [7.47]	23.3 [6.83]	21.2 [6.21]	31.0 [9.09]	28.4 [8.32]	25.7 [7.53]	35.1 [10.29]	32.2 [9.44]	29.2 [8.56]	
	Power	2.9	2.8	2.8	2.8	2.8	2.8	2.8	2.8	2.7	
100 [37.8]	Total BTUH [kW]	38.9 [11.40]	37.5 [10.99]	36.1 [10.58]	36.4 [10.67]	35.1 [10.29]	33.9 [9.94]	33.6 [9.85]	32.4 [9.50]	31.3 [9.17]	
	Sens BTUH [kW]	24.8 [7.27]	22.7 [6.65]	20.5 [6.01]	30.3 [8.88]	27.7 [8.12]	25.1 [7.36]	33.6 [9.85]	31.5 [9.23]	28.6 [8.38]	
	Power	3.0	3.0	2.9	3.0	2.9	2.9	3.0	2.9	2.9	
105 [40.6]	Total BTUH [kW]	37.4 [10.96]	36.1 [10.58]	34.8 [10.20]	35.0 [10.26]	33.8 [9.91]	32.5 [9.52]	32.2 [9.44]	31.0 [9.09]	29.9 [8.76]	
	Sens BTUH [kW]	24.1 [7.06]	22.0 [6.45]	20.0 [5.86]	29.5 [8.65]	27.0 [7.91]	24.5 [7.18]	32.2 [9.44]	30.9 [9.06]	28.0 [8.21]	
	Power	3.1	3.1	3.0	3.1	3.0	3.0	3.1	3.0	3.0	
110 [43.3]	Total BTUH [kW]	36.1 [10.58]	34.8 [10.20]	33.5 [9.82]	33.6 [9.85]	32.4 [9.50]	31.3 [9.17]	30.8 [9.03]	29.7 [8.70]	28.6 [8.38]	
	Sens BTUH [kW]	23.4 [6.86]	21.4 [6.27]	19.4 [5.69]	28.9 [8.47]	26.4 [7.74]	24.0 [7.03]	30.8 [9.03]	29.7 [8.70]	27.5 [8.06]	
	Power	3.3	3.2	3.2	3.2	3.2	3.1	3.2	3.2	3.1	
115 [46.1]	Total BTUH [kW]	34.8 [10.20]	33.6 [9.85]	32.4 [9.50]	32.4 [9.50]	31.2 [9.14]	30.1 [8.82]	29.5 [8.65]	28.5 [8.35]	27.5 [8.06]	
	Sens BTUH [kW]	22.9 [6.71]	20.9 [6.13]	19.0 [5.57]	28.4 [8.32]	26.0 [7.62]	23.5 [6.89]	29.5 [8.65]	28.5 [8.35]	27.0 [7.91]	
	Power	3.4	3.3	3.3	3.4	3.3	3.2	3.3	3.3	3.2	

GROSS SYSTEMS PERFORMANCE DATA—RQNM-A042

		ENTERING INDOOR AIR @ 80°F [26.7°C] dbE ①									
wbE		71°F [21.7°C]			67°F [19.4°C]			63°F [17.2°C]			
CFM [L/s]		1740 [821]	1450 [684]	1160 [547]	1740 [821]	1450 [684]	1160 [547]	1740 [821]	1450 [684]	1160 [547]	
DR ①		.23	.21	.17	.23	.21	.17	.23	.21	.17	
OUTDOOR DRY BULB TEMPERATURE °F [°C]	75 [23.9]	Total BTUH [kW]	52.6 [15.42]	50.7 [14.86]	48.9 [14.33]	50.7 [14.86]	48.9 [14.33]	47.1 [13.80]	47.2 [13.83]	45.5 [13.33]	43.9 [12.87]
		Sens BTUH [kW]	31.7 [9.29]	29.0 [8.50]	26.3 [7.71]	37.8 [11.08]	34.6 [10.14]	31.4 [9.20]	42.9 [12.57]	39.2 [11.49]	35.5 [10.40]
		Power	2.8	2.7	2.7	2.8	2.7	2.7	2.8	2.7	2.7
	80 [26.7]	Total BTUH [kW]	52.2 [15.30]	50.4 [14.77]	48.5 [14.21]	50.3 [14.74]	48.6 [14.24]	46.8 [13.72]	46.8 [13.72]	45.2 [13.25]	43.5 [12.75]
		Sens BTUH [kW]	31.3 [9.17]	28.6 [8.38]	26.0 [7.62]	37.4 [10.96]	34.3 [10.05]	31.1 [9.11]	42.5 [12.46]	38.9 [11.40]	35.2 [10.32]
		Power	3.0	2.9	2.9	2.9	2.9	2.8	2.9	2.9	2.9
	85 [29.4]	Total BTUH [kW]	51.1 [14.98]	49.3 [14.45]	47.5 [13.92]	49.2 [14.42]	47.5 [13.92]	45.8 [13.42]	45.7 [13.39]	44.1 [12.92]	42.5 [12.46]
		Sens BTUH [kW]	30.7 [9.00]	28.1 [8.24]	25.5 [7.47]	36.8 [10.79]	33.7 [9.88]	30.5 [8.94]	41.9 [12.28]	38.3 [11.22]	34.7 [10.17]
		Power	3.1	3.1	3.0	3.1	3.1	3.0	3.1	3.1	3.0
	90 [32.2]	Total BTUH [kW]	49.5 [14.51]	47.8 [14.01]	46.0 [13.48]	47.6 [13.95]	46.0 [13.48]	44.3 [12.98]	44.1 [12.92]	42.6 [12.48]	41.0 [12.02]
Sens BTUH [kW]		29.9 [8.76]	27.3 [8.00]	24.8 [7.27]	36.0 [10.55]	33.0 [9.67]	29.9 [8.76]	41.0 [12.02]	37.6 [11.02]	34.1 [9.99]	
Power		3.3	3.2	3.2	3.3	3.2	3.2	3.3	3.2	3.2	
95 [35]	Total BTUH [kW]	47.6 [13.95]	45.9 [13.45]	44.3 [12.98]	45.7 [13.39]	44.1 [12.92]	42.5 [12.46]	42.2 [12.37]	40.8 [11.96]	39.3 [11.52]	
	Sens BTUH [kW]	29.0 [8.50]	26.5 [7.77]	24.1 [7.06]	35.1 [10.29]	32.1 [9.41]	29.1 [8.53]	40.3 [11.81]	36.8 [10.79]	33.3 [9.76]	
	Power	3.5	3.4	3.4	3.4	3.4	3.3	3.5	3.4	3.3	
100 [37.8]	Total BTUH [kW]	45.6 [13.36]	44.0 [12.90]	42.4 [12.43]	43.7 [12.81]	42.2 [12.37]	40.7 [11.93]	40.2 [11.78]	38.8 [11.37]	37.4 [10.96]	
	Sens BTUH [kW]	28.1 [8.24]	25.7 [7.53]	23.3 [6.83]	34.2 [10.02]	31.3 [9.17]	28.4 [8.32]	39.3 [11.52]	35.9 [10.52]	32.6 [9.55]	
	Power	3.6	3.6	3.5	3.6	3.5	3.5	3.6	3.6	3.5	
105 [40.6]	Total BTUH [kW]	43.7 [12.81]	42.2 [12.37]	40.6 [11.90]	41.8 [12.25]	40.4 [11.84]	38.9 [11.40]	38.3 [11.22]	37.0 [10.84]	35.6 [10.43]	
	Sens BTUH [kW]	27.3 [8.00]	25.0 [7.33]	22.6 [6.62]	33.4 [9.79]	30.6 [8.97]	27.7 [8.12]	38.3 [11.22]	35.2 [10.32]	31.9 [9.35]	
	Power	3.8	3.7	3.7	3.8	3.7	3.7	3.8	3.7	3.7	
110 [43.3]	Total BTUH [kW]	42.1 [12.34]	40.6 [11.90]	39.1 [11.46]	40.2 [11.78]	38.8 [11.37]	37.4 [10.96]	36.7 [10.76]	35.4 [10.37]	34.1 [9.99]	
	Sens BTUH [kW]	26.7 [7.83]	24.4 [7.15]	22.1 [6.48]	32.8 [9.61]	30.0 [8.79]	27.2 [7.97]	36.7 [10.76]	34.6 [10.14]	31.4 [9.20]	
	Power	4.0	3.9	3.8	3.9	3.9	3.8	4.0	3.9	3.8	
115 [46.1]	Total BTUH [kW]	41.0 [12.02]	39.6 [11.61]	38.1 [11.17]	39.1 [11.46]	37.8 [11.08]	36.4 [10.67]	35.6 [10.43]	34.4 [10.08]	33.1 [9.70]	
	Sens BTUH [kW]	26.3 [7.71]	24.0 [7.03]	21.8 [6.39]	32.4 [9.50]	29.6 [8.67]	26.9 [7.88]	35.6 [10.43]	34.3 [10.05]	31.1 [9.11]	
	Power	4.1	4.1	4.0	4.1	4.0	4.0	4.1	4.1	4.0	

DR —Depression ratio
dbE—Entering air dry bulb
wbE—Entering air wet bulb

Total —Total capacity x 1000 BTUH
Sens —Sensible capacity x 1000 BTUH
Power—KW input

NOTES: ① When the entering air dry bulb is other than 80°F [27°C], adjust the sensible capacity from the table by adding $[1.10 \times \text{CFM} \times (1 - \text{DR}) \times (\text{dbE} - 80)]$.

[] Designates Metric Conversions

SYSTEMS PERFORMANCE—RQNM- SERIES



GROSS SYSTEMS PERFORMANCE DATA—RQNM-A048

		ENTERING INDOOR AIR @ 80°F [26.7°C] dbE ①									
		wbE	71°F [21.7°C]			67°F [19.4°C]			63°F [17.2°C]		
		CFM [L/s]	1860 [878]	1550 [732]	1240 [585]	1860 [878]	1550 [732]	1240 [585]	1860 [878]	1550 [732]	1240 [585]
		DR ①	.12	.09	.05	.12	.09	.05	.12	.09	.05
OUTDOOR DRY BULB TEMPERATURE °F [°C]	75 [23.9]	Total BTUH [kW]	59.4 [17.41]	57.3 [16.79]	55.2 [16.18]	56.9 [16.68]	54.9 [16.09]	52.9 [15.50]	52.3 [15.33]	50.5 [14.80]	48.7 [14.27]
		Sens BTUH [kW]	36.9 [10.81]	33.7 [9.88]	30.6 [8.97]	44.1 [12.92]	40.3 [11.81]	36.5 [10.70]	48.7 [14.27]	44.5 [13.04]	40.4 [11.84]
		Power	3.0	3.0	2.9	3.0	3.0	2.9	3.0	2.9	2.9
	80 [26.7]	Total BTUH [kW]	59.1 [17.32]	57.0 [16.71]	54.9 [16.09]	56.5 [16.56]	54.5 [15.97]	52.6 [15.42]	52.0 [15.24]	50.2 [14.71]	48.3 [14.16]
		Sens BTUH [kW]	36.3 [10.64]	33.2 [9.73]	30.1 [8.82]	43.5 [12.75]	39.8 [11.66]	36.1 [10.58]	48.0 [14.07]	44.0 [12.90]	39.9 [11.69]
		Power	3.2	3.1	3.1	3.2	3.2	3.1	3.2	3.1	3.1
	85 [29.4]	Total BTUH [kW]	57.9 [16.97]	55.8 [16.35]	53.8 [15.77]	55.3 [16.21]	53.4 [15.65]	51.4 [15.06]	50.8 [14.89]	49.0 [14.36]	47.2 [13.83]
		Sens BTUH [kW]	35.7 [10.46]	32.7 [9.58]	29.6 [8.67]	42.9 [12.57]	39.3 [11.52]	35.6 [10.43]	47.8 [14.01]	43.5 [12.75]	39.4 [11.55]
		Power	3.4	3.3	3.3	3.4	3.4	3.3	3.4	3.3	3.3
	90 [32.2]	Total BTUH [kW]	56.0 [16.41]	54.1 [15.86]	52.1 [15.27]	53.5 [15.68]	51.6 [15.12]	49.7 [14.57]	49.0 [14.36]	47.2 [13.83]	45.5 [13.33]
Sens BTUH [kW]		35.0 [10.26]	32.0 [9.38]	29.0 [8.50]	42.2 [12.37]	38.6 [11.31]	35.0 [10.26]	47.0 [13.77]	42.8 [12.54]	38.8 [11.37]	
Power		3.6	3.5	3.5	3.6	3.5	3.5	3.6	3.5	3.4	
95 [35]	Total BTUH [kW]	53.8 [15.77]	51.9 [15.21]	50.1 [14.68]	51.3 [15.03]	49.5 [14.51]	47.7 [13.98]	46.8 [13.72]	45.1 [13.22]	43.5 [12.75]	
	Sens BTUH [kW]	34.2 [10.02]	31.3 [9.17]	28.4 [8.32]	41.4 [12.13]	37.9 [11.11]	34.3 [10.05]	45.7 [13.39]	42.1 [12.34]	38.2 [11.20]	
	Power	3.8	3.7	3.7	3.8	3.7	3.7	3.8	3.7	3.6	
100 [37.8]	Total BTUH [kW]	51.5 [15.09]	49.7 [14.57]	47.9 [14.04]	48.9 [14.33]	47.2 [13.83]	45.5 [13.33]	44.4 [13.01]	42.9 [12.57]	41.3 [12.10]	
	Sens BTUH [kW]	33.3 [9.76]	30.5 [8.94]	27.6 [8.09]	40.5 [11.87]	37.1 [10.87]	33.6 [9.85]	44.4 [13.01]	41.3 [12.10]	37.4 [10.96]	
	Power	4.0	3.9	3.8	4.0	3.9	3.9	4.0	3.9	3.8	
105 [40.6]	Total BTUH [kW]	49.3 [14.45]	47.5 [13.92]	45.8 [13.42]	46.7 [13.69]	45.1 [13.22]	43.4 [12.72]	42.2 [12.37]	40.7 [11.93]	39.2 [11.49]	
	Sens BTUH [kW]	32.4 [9.50]	29.6 [8.67]	26.9 [7.88]	39.6 [11.61]	36.2 [10.61]	32.8 [9.61]	42.2 [12.37]	40.4 [11.84]	36.7 [10.76]	
	Power	4.2	4.1	4.0	4.2	4.1	4.1	4.1	4.1	4.0	
110 [43.3]	Total BTUH [kW]	47.4 [13.89]	45.7 [13.39]	44.1 [12.92]	44.8 [13.13]	43.3 [12.69]	41.7 [12.22]	40.3 [11.81]	38.9 [11.40]	37.5 [10.99]	
	Sens BTUH [kW]	31.4 [9.20]	28.7 [8.41]	26.0 [7.62]	38.6 [11.31]	35.3 [10.35]	32.0 [9.38]	40.3 [11.81]	38.9 [11.40]	35.8 [10.49]	
	Power	4.4	4.3	4.2	4.4	4.3	4.2	4.3	4.3	4.2	
115 [46.1]	Total BTUH [kW]	46.1 [13.51]	44.5 [13.04]	42.9 [12.57]	43.6 [12.78]	42.0 [12.31]	40.5 [11.87]	39.0 [11.43]	37.7 [11.05]	36.3 [10.64]	
	Sens BTUH [kW]	30.3 [8.88]	27.7 [8.12]	25.2 [7.39]	37.5 [10.99]	34.3 [10.05]	31.1 [9.11]	39.0 [11.43]	37.7 [11.05]	35.0 [10.26]	
	Power	4.6	4.5	4.4	4.6	4.5	4.4	4.5	4.5	4.4	

GROSS SYSTEMS PERFORMANCE DATA—RQNM-A060

		ENTERING INDOOR AIR @ 80°F [26.7°C] dbE ①									
		wbE	71°F [21.7°C]			67°F [19.4°C]			63°F [17.2°C]		
		CFM [L/s]	2280 [1076]	1900 [897]	1520 [717]	2280 [1076]	1900 [897]	1520 [717]	2280 [1076]	1900 [897]	1520 [717]
		DR ①	.11	.07	.03	.11	.07	.03	.11	.07	.03
OUTDOOR DRY BULB TEMPERATURE °F [°C]	75 [23.9]	Total BTUH [kW]	76.5 [22.42]	73.8 [21.63]	71.2 [20.87]	72.1 [21.13]	69.5 [20.37]	67.0 [19.64]	68.0 [19.93]	65.6 [19.23]	63.2 [18.52]
		Sens BTUH [kW]	46.7 [13.69]	42.7 [12.51]	38.7 [11.34]	56.0 [16.41]	51.2 [15.01]	46.4 [13.60]	63.5 [18.61]	58.1 [17.03]	52.7 [15.44]
		Power	3.7	3.6	3.6	3.7	3.6	3.5	3.6	3.6	3.5
	80 [26.7]	Total BTUH [kW]	74.8 [21.92]	72.2 [21.16]	69.6 [20.40]	70.4 [20.63]	67.9 [19.90]	65.4 [19.17]	66.3 [19.43]	64.0 [18.76]	61.7 [18.08]
		Sens BTUH [kW]	46.0 [13.48]	42.1 [12.34]	38.2 [11.20]	55.3 [16.21]	50.5 [14.80]	45.8 [13.42]	62.8 [18.40]	57.5 [16.85]	52.1 [15.27]
		Power	3.9	3.9	3.8	3.9	3.8	3.8	3.8	3.8	3.7
	85 [29.4]	Total BTUH [kW]	72.9 [21.36]	70.3 [20.60]	67.8 [19.87]	68.5 [20.08]	66.1 [19.37]	63.7 [18.67]	64.4 [18.87]	62.1 [18.20]	59.9 [17.55]
		Sens BTUH [kW]	45.0 [13.19]	41.2 [12.07]	37.3 [10.93]	54.3 [15.91]	49.6 [14.54]	45.0 [13.19]	61.9 [18.14]	56.6 [16.59]	51.3 [15.03]
		Power	4.2	4.1	4.0	4.1	4.1	4.0	4.1	4.0	3.9
	90 [32.2]	Total BTUH [kW]	70.8 [20.75]	68.3 [20.02]	65.9 [19.31]	66.4 [19.46]	64.1 [18.79]	61.7 [18.08]	62.3 [18.26]	60.1 [17.61]	57.9 [16.97]
Sens BTUH [kW]		43.9 [12.87]	40.1 [11.75]	36.4 [10.67]	53.1 [15.56]	48.6 [14.24]	44.0 [12.90]	60.8 [17.82]	55.5 [16.27]	50.3 [14.74]	
Power		4.4	4.3	4.2	4.3	4.3	4.2	4.3	4.2	4.2	
95 [35]	Total BTUH [kW]	68.6 [20.18]	66.2 [19.40]	63.8 [18.70]	64.2 [18.82]	61.9 [18.14]	59.7 [17.50]	60.1 [17.61]	58.0 [17.00]	55.9 [16.38]	
	Sens BTUH [kW]	42.6 [12.48]	39.0 [11.43]	35.3 [10.35]	51.9 [15.21]	47.4 [13.89]	43.0 [12.60]	59.4 [17.41]	54.4 [15.94]	49.3 [14.45]	
	Power	4.6	4.5	4.5	4.6	4.5	4.4	4.5	4.5	4.4	
100 [37.8]	Total BTUH [kW]	66.3 [19.43]	64.0 [18.76]	61.7 [18.08]	61.9 [18.14]	59.7 [17.50]	57.6 [16.88]	57.8 [16.94]	55.8 [16.35]	53.8 [15.77]	
	Sens BTUH [kW]	41.4 [12.13]	37.8 [11.08]	34.3 [10.05]	50.6 [14.83]	46.3 [13.57]	42.0 [12.31]	57.8 [16.94]	53.2 [15.59]	48.2 [14.13]	
	Power	4.8	4.8	4.7	4.8	4.7	4.7	4.8	4.7	4.6	
105 [40.6]	Total BTUH [kW]	64.0 [18.76]	61.8 [18.11]	59.5 [17.44]	59.6 [17.47]	57.5 [16.85]	55.4 [16.24]	55.5 [16.27]	53.5 [15.68]	51.6 [15.12]	
	Sens BTUH [kW]	40.2 [11.78]	36.8 [10.79]	33.4 [9.79]	49.5 [14.51]	45.2 [13.25]	41.0 [12.02]	55.5 [16.27]	52.2 [15.30]	47.3 [13.86]	
	Power	5.1	5.0	4.9	5.0	5.0	4.9	5.0	4.9	4.8	
110 [43.3]	Total BTUH [kW]	61.6 [18.05]	59.5 [17.44]	57.3 [16.79]	57.2 [16.76]	55.2 [16.18]	53.2 [15.59]	53.1 [15.56]	51.3 [15.03]	49.4 [14.48]	
	Sens BTUH [kW]	39.3 [11.52]	35.9 [10.52]	32.6 [9.55]	48.5 [14.21]	44.4 [13.01]	40.2 [11.78]	53.1 [15.56]	51.3 [15.03]	46.5 [13.63]	
	Power	5.3	5.2	5.1	5.3	5.2	5.1	5.2	5.1	5.1	
115 [46.1]	Total BTUH [kW]	59.3 [17.38]	57.2 [16.76]	55.1 [16.15]	54.9 [16.09]	52.9 [15.50]	51.0 [14.95]	50.8 [14.89]	49.0 [14.36]	47.2 [13.83]	
	Sens BTUH [kW]	38.6 [11.31]	35.3 [10.35]	32.0 [9.38]	47.9 [14.04]	43.8 [12.84]	39.7 [11.63]	50.8 [14.89]	49.0 [14.36]	46.0 [13.48]	
	Power	5.5	5.4	5.4	5.5	5.4	5.3	5.5	5.4	5.3	

DR —Depression ratio
dbE—Entering air dry bulb
wbE—Entering air wet bulb

Total —Total capacity x 1000 BTUH
Sens —Sensible capacity x 1000 BTUH
Power—kW input

NOTES: ① When the entering air dry bulb is other than 80°F [27°C], adjust the sensible capacity from the table by adding $[1.10 \times \text{CFM} \times (1 - \text{DR}) \times (\text{dbE} - 80)]$.

[] Designates Metric Conversions



SYSTEMS PERFORMANCE—RQPM- SERIES

GROSS SYSTEMS PERFORMANCE DATA—RQPM-A024

wbE		ENTERING INDOOR AIR @ 80°F [26.7°C] dbE ①									
		71°F [21.7°C]			67°F [19.4°C]			63°F [17.2°C]			
CFM [L/s]		960 [453]	800 [378]	640 [302]	960 [453]	800 [378]	640 [302]	960 [453]	800 [378]	640 [302]	
DR ①		.14	.10	.05	.14	.10	.05	.14	.10	.05	
OUTDOOR DRY BULB TEMPERATURE °F [°C]	75 [23.9]	Total BTUH [kW]	30.4 [8.91]	29.3 [8.59]	28.2 [8.26]	28.5 [8.35]	27.5 [8.06]	26.5 [7.77]	26.9 [7.88]	26.0 [7.62]	25.1 [7.36]
		Sens BTUH [kW]	18.6 [5.45]	17.0 [4.98]	15.4 [4.51]	22.3 [6.54]	20.4 [5.98]	18.5 [5.42]	26.0 [7.62]	23.8 [6.98]	21.5 [6.30]
		Power	1.6	1.5	1.5	1.5	1.5	1.5	1.6	1.5	1.5
	80 [26.7]	Total BTUH [kW]	29.6 [8.67]	28.6 [8.38]	27.5 [8.06]	27.7 [8.12]	26.7 [7.83]	25.8 [7.56]	26.2 [7.68]	25.3 [7.41]	24.4 [7.15]
		Sens BTUH [kW]	18.2 [5.33]	16.7 [4.89]	15.1 [4.43]	21.9 [6.42]	20.1 [5.89]	18.2 [5.33]	25.7 [7.53]	23.4 [6.86]	21.3 [6.24]
		Power	1.6	1.6	1.6	1.6	1.6	1.6	1.7	1.6	1.6
	85 [29.4]	Total BTUH [kW]	28.7 [8.41]	27.7 [8.12]	26.7 [7.83]	26.8 [7.85]	25.9 [7.59]	24.9 [7.30]	25.3 [7.41]	24.4 [7.15]	23.5 [6.89]
		Sens BTUH [kW]	17.8 [5.22]	16.3 [4.78]	14.8 [4.34]	21.5 [6.30]	19.7 [5.77]	17.8 [5.22]	25.2 [7.39]	23.1 [6.77]	20.9 [6.13]
		Power	1.7	1.7	1.7	1.7	1.7	1.7	1.7	1.7	1.7
	90 [32.2]	Total BTUH [kW]	27.8 [8.15]	26.8 [7.85]	25.9 [7.59]	25.9 [7.59]	25.0 [7.33]	24.1 [7.06]	24.4 [7.15]	23.5 [6.89]	22.7 [6.65]
Sens BTUH [kW]		17.4 [5.10]	15.9 [4.66]	14.4 [4.22]	21.1 [6.18]	19.3 [5.66]	17.5 [5.13]	24.4 [7.15]	22.7 [6.65]	20.5 [6.01]	
Power		1.8	1.8	1.8	1.8	1.8	1.8	1.8	1.8	1.8	
95 [35]	Total BTUH [kW]	26.8 [7.85]	25.9 [7.59]	24.9 [7.30]	24.9 [7.30]	24.0 [7.03]	23.1 [6.77]	23.4 [6.86]	22.6 [6.62]	21.7 [6.36]	
	Sens BTUH [kW]	16.9 [4.95]	15.4 [4.51]	14.0 [4.10]	20.6 [6.04]	18.8 [5.51]	17.1 [5.01]	23.4 [6.86]	22.2 [6.51]	20.1 [5.89]	
	Power	1.9	1.9	1.9	1.9	1.9	1.8	1.9	1.9	1.9	
100 [37.8]	Total BTUH [kW]	25.8 [7.56]	24.9 [7.30]	24.0 [7.03]	23.9 [7.00]	23.0 [6.74]	22.2 [6.51]	22.4 [6.56]	21.6 [6.33]	20.8 [6.10]	
	Sens BTUH [kW]	16.4 [4.81]	15.0 [4.40]	13.6 [3.99]	20.1 [5.89]	18.3 [5.36]	16.6 [4.86]	22.4 [6.56]	21.6 [6.33]	19.7 [5.77]	
	Power	2.0	2.0	1.9	2.0	2.0	1.9	2.0	2.0	1.9	
105 [40.6]	Total BTUH [kW]	24.8 [7.27]	23.9 [7.00]	23.0 [6.74]	22.8 [6.68]	22.0 [6.45]	21.2 [6.21]	21.3 [6.24]	20.6 [6.04]	19.8 [5.80]	
	Sens BTUH [kW]	15.8 [4.63]	14.5 [4.25]	13.1 [3.84]	19.5 [5.71]	17.9 [5.25]	16.2 [4.75]	21.3 [6.24]	20.6 [6.04]	19.3 [5.66]	
	Power	2.1	2.1	2.0	2.1	2.1	2.0	2.1	2.1	2.0	
110 [43.3]	Total BTUH [kW]	23.8 [6.98]	22.9 [6.71]	22.1 [6.48]	21.9 [6.42]	21.1 [6.18]	20.3 [5.95]	20.4 [5.98]	19.6 [5.74]	18.9 [5.54]	
	Sens BTUH [kW]	15.3 [4.48]	14.0 [4.10]	12.7 [3.72]	19.0 [5.57]	17.4 [5.10]	15.8 [4.63]	20.4 [5.98]	19.6 [5.74]	18.9 [5.54]	
	Power	2.2	2.2	2.1	2.2	2.1	2.1	2.2	2.2	2.1	
115 [46.1]	Total BTUH [kW]	22.9 [6.71]	22.1 [6.48]	21.3 [6.24]	20.9 [6.13]	20.2 [5.92]	19.5 [5.71]	19.4 [5.69]	18.8 [5.51]	18.1 [5.30]	
	Sens BTUH [kW]	14.8 [4.34]	13.6 [3.99]	12.3 [3.60]	18.5 [5.42]	17.0 [4.98]	15.4 [4.51]	19.4 [5.69]	18.8 [5.51]	18.1 [5.30]	
	Power	2.3	2.2	2.2	2.3	2.2	2.2	2.3	2.2	2.2	

GROSS SYSTEMS PERFORMANCE DATA—RQPM-A030

wbE		ENTERING INDOOR AIR @ 80°F [26.7°C] dbE ①									
		71°F [21.7°C]			67°F [19.4°C]			63°F [17.2°C]			
CFM [L/s]		1200 [566]	1000 [472]	800 [378]	1200 [566]	1000 [472]	800 [378]	1200 [566]	1000 [472]	800 [378]	
DR ①		.13	.09	.04	.13	.09	.04	.13	.09	.04	
OUTDOOR DRY BULB TEMPERATURE °F [°C]	75 [23.9]	Total BTUH [kW]	37.9 [11.11]	36.6 [10.73]	35.3 [10.35]	34.9 [10.23]	33.7 [9.88]	32.4 [9.50]	33.0 [9.67]	31.9 [9.35]	30.7 [9.00]
		Sens BTUH [kW]	23.4 [6.86]	21.4 [6.27]	19.4 [5.69]	27.6 [8.09]	25.2 [7.39]	22.9 [6.71]	30.9 [9.06]	28.4 [8.32]	25.7 [7.53]
		Power	1.9	1.9	1.8	1.9	1.9	1.8	1.9	1.9	1.8
	80 [26.7]	Total BTUH [kW]	37.0 [10.84]	35.7 [10.46]	34.4 [10.08]	33.9 [9.94]	32.7 [9.58]	31.5 [9.23]	32.0 [9.38]	30.9 [9.06]	29.8 [8.73]
		Sens BTUH [kW]	23.0 [6.74]	21.0 [6.15]	19.1 [5.60]	27.2 [7.97]	24.9 [7.30]	22.6 [6.62]	30.8 [9.03]	28.0 [8.21]	25.4 [7.44]
		Power	2.0	2.0	1.9	2.0	2.0	1.9	2.0	2.0	1.9
	85 [29.4]	Total BTUH [kW]	35.9 [10.52]	34.6 [10.14]	33.4 [9.79]	32.9 [9.64]	31.7 [9.29]	30.5 [8.94]	31.0 [9.09]	29.9 [8.76]	28.8 [8.44]
		Sens BTUH [kW]	22.6 [6.62]	20.6 [6.04]	18.7 [5.48]	26.8 [7.85]	24.5 [7.18]	22.2 [6.51]	30.3 [8.88]	27.6 [8.09]	25.0 [7.33]
		Power	2.1	2.1	2.0	2.1	2.1	2.0	2.1	2.1	2.0
	90 [32.2]	Total BTUH [kW]	34.8 [10.20]	33.6 [9.85]	32.3 [9.47]	31.7 [9.29]	30.6 [8.97]	29.5 [8.65]	29.9 [8.76]	28.8 [8.44]	27.8 [8.15]
Sens BTUH [kW]		22.0 [6.45]	20.1 [5.89]	18.3 [5.36]	26.2 [7.68]	24.0 [7.03]	21.8 [6.39]	29.5 [8.65]	27.1 [7.94]	24.6 [7.21]	
Power		2.2	2.2	2.1	2.2	2.2	2.1	2.2	2.2	2.1	
95 [35]	Total BTUH [kW]	33.6 [9.85]	32.4 [9.50]	31.2 [9.14]	30.5 [8.94]	29.5 [8.65]	28.4 [8.32]	28.7 [8.41]	27.7 [8.12]	26.7 [7.83]	
	Sens BTUH [kW]	21.4 [6.27]	19.6 [5.74]	17.8 [5.22]	25.7 [7.53]	23.5 [6.89]	21.3 [6.24]	28.7 [8.41]	26.7 [7.83]	24.1 [7.06]	
	Power	2.3	2.3	2.2	2.3	2.3	2.2	2.3	2.3	2.2	
100 [37.8]	Total BTUH [kW]	32.4 [9.50]	31.2 [9.14]	30.1 [8.82]	29.3 [8.59]	28.3 [8.29]	27.3 [8.00]	27.5 [8.06]	26.5 [7.77]	25.5 [7.47]	
	Sens BTUH [kW]	20.8 [6.10]	19.1 [5.60]	17.3 [5.07]	25.1 [7.36]	22.9 [6.71]	20.8 [6.10]	27.5 [8.06]	26.0 [7.62]	23.6 [6.92]	
	Power	2.4	2.4	2.3	2.4	2.4	2.3	2.4	2.4	2.3	
105 [40.6]	Total BTUH [kW]	31.1 [9.11]	30.0 [8.79]	28.9 [8.47]	28.1 [8.24]	27.1 [7.94]	26.1 [7.65]	26.2 [7.68]	25.3 [7.41]	24.4 [7.15]	
	Sens BTUH [kW]	20.2 [5.92]	18.5 [5.42]	16.8 [4.92]	24.4 [7.15]	22.3 [6.54]	20.3 [5.95]	26.2 [7.68]	25.3 [7.41]	23.1 [6.77]	
	Power	2.5	2.5	2.4	2.5	2.5	2.4	2.5	2.5	2.4	
110 [43.3]	Total BTUH [kW]	29.8 [8.73]	28.8 [8.44]	27.7 [8.12]	26.8 [7.85]	25.8 [7.56]	24.9 [7.30]	24.9 [7.30]	24.0 [7.03]	23.1 [6.77]	
	Sens BTUH [kW]	19.6 [5.74]	17.9 [5.25]	16.2 [4.75]	23.8 [6.98]	21.8 [6.39]	19.8 [5.80]	24.9 [7.30]	24.0 [7.03]	22.6 [6.62]	
	Power	2.6	2.6	2.5	2.6	2.6	2.5	2.6	2.6	2.5	
115 [46.1]	Total BTUH [kW]	28.5 [8.35]	27.5 [8.06]	26.5 [7.77]	25.4 [7.44]	24.5 [7.18]	23.6 [6.92]	23.6 [6.92]	22.7 [6.65]	21.9 [6.42]	
	Sens BTUH [kW]	19.0 [5.57]	17.4 [5.10]	15.8 [4.63]	23.2 [6.80]	21.3 [6.24]	19.3 [5.66]	23.6 [6.92]	22.7 [6.65]	21.9 [6.42]	
	Power	2.7	2.7	2.6	2.7	2.7	2.6	2.7	2.7	2.6	

DR —Depression ratio
dbE—Entering air dry bulb
wbE—Entering air wet bulb

Total —Total capacity x 1000 BTUH
Sens —Sensible capacity x 1000 BTUH
Power—KW input

NOTES: ① When the entering air dry bulb is other than 80°F [27°C], adjust the sensible capacity from the table by adding [1.10 x CFM x (1 - DR) x (dbE - 80)].

[] Designates Metric Conversions



GROSS SYSTEMS PERFORMANCE DATA—RQPM-A036

		ENTERING INDOOR AIR @ 80°F [26.7°C] dbE ①									
wbE		71°F [21.7°C]			67°F [19.4°C]			63°F [17.2°C]			
CFM [L/s]		1440 [680]	1200 [566]	960 [453]	1440 [680]	1200 [566]	960 [453]	1440 [680]	1200 [566]	960 [453]	
DR ①		.14	.10	.05	.14	.10	.05	.14	.10	.05	
OUTDOOR DRY BULB TEMPERATURE °F [°C]	75 [23.9]	Total BTUH [kW] Sens BTUH [kW] Power	45.3 [13.28] 27.8 [8.15] 2.4	43.7 [12.81] 25.4 [7.44] 2.4	42.1 [12.34] 23.1 [6.77] 2.3	42.5 [12.46] 33.3 [9.76] 2.4	41.0 [12.02] 30.5 [8.94] 2.3	39.5 [11.58] 27.6 [8.09] 2.3	39.6 [11.61] 37.2 [10.90] 2.4	38.3 [11.22] 34.1 [9.99] 2.3	36.9 [10.81] 31.0 [9.09] 2.3
	80 [26.7]	Total BTUH [kW] Sens BTUH [kW] Power	44.2 [12.95] 27.3 [8.00] 2.6	42.7 [12.51] 25.0 [7.33] 2.5	41.1 [12.05] 22.7 [6.65] 2.5	41.4 [12.13] 32.8 [9.61] 2.5	39.9 [11.69] 30.0 [8.79] 2.5	38.5 [11.28] 27.2 [7.97] 2.4	38.6 [11.31] 37.0 [10.84] 2.5	37.2 [10.90] 33.7 [9.88] 2.5	35.9 [10.52] 30.5 [8.94] 2.4
	85 [29.4]	Total BTUH [kW] Sens BTUH [kW] Power	43.0 [12.60] 26.7 [7.83] 2.7	41.5 [12.16] 24.5 [7.18] 2.6	39.9 [11.69] 22.2 [6.51] 2.6	40.2 [11.78] 32.2 [9.44] 2.6	38.7 [11.34] 29.5 [8.65] 2.6	37.3 [10.93] 26.7 [7.83] 2.6	37.3 [10.93] 36.4 [10.67] 2.6	36.0 [10.55] 33.2 [9.73] 2.6	34.7 [10.17] 30.1 [8.82] 2.6
	90 [32.2]	Total BTUH [kW] Sens BTUH [kW] Power	41.6 [12.19] 26.1 [7.65] 2.8	40.1 [11.75] 23.9 [7.00] 2.8	38.7 [11.34] 21.6 [6.33] 2.7	38.8 [11.37] 31.6 [9.26] 2.8	37.4 [10.96] 28.9 [8.47] 2.7	36.1 [10.58] 26.2 [7.68] 2.7	35.9 [10.52] 35.5 [10.40] 2.8	34.7 [10.17] 32.5 [9.52] 2.7	33.4 [9.79] 29.5 [8.65] 2.7
	95 [35]	Total BTUH [kW] Sens BTUH [kW] Power	40.1 [11.75] 25.4 [7.44] 3.0	38.7 [11.34] 23.2 [6.80] 2.9	37.3 [10.93] 21.0 [6.15] 2.9	37.3 [10.93] 30.9 [9.06] 2.9	36.0 [10.55] 28.2 [8.26] 2.9	34.7 [10.17] 25.6 [7.50] 2.8	34.5 [10.11] 34.5 [10.11] 2.9	33.3 [9.76] 32.0 [9.38] 2.9	32.1 [9.41] 28.9 [8.47] 2.8
	100 [37.8]	Total BTUH [kW] Sens BTUH [kW] Power	38.6 [11.31] 24.6 [7.21] 3.1	37.3 [10.93] 22.5 [6.59] 3.0	35.9 [10.52] 20.4 [5.98] 3.0	35.8 [10.49] 30.1 [8.82] 3.0	34.6 [10.14] 27.6 [8.09] 3.0	33.3 [9.76] 25.0 [7.33] 2.9	33.0 [9.67] 33.0 [9.67] 3.0	31.8 [9.32] 31.2 [9.14] 3.0	30.7 [9.00] 28.3 [8.29] 2.9
	105 [40.6]	Total BTUH [kW] Sens BTUH [kW] Power	37.1 [10.87] 23.9 [7.00] 3.2	35.8 [10.49] 21.8 [6.39] 3.2	34.5 [10.11] 19.8 [5.80] 3.1	34.3 [10.05] 29.4 [8.62] 3.2	33.1 [9.70] 26.9 [7.88] 3.1	31.9 [9.35] 24.4 [7.15] 3.1	31.5 [9.23] 31.5 [9.23] 3.2	30.4 [8.91] 30.4 [8.91] 3.1	29.3 [8.59] 27.7 [8.12] 3.1
	110 [43.3]	Total BTUH [kW] Sens BTUH [kW] Power	35.6 [10.43] 23.2 [6.80] 3.4	34.4 [10.08] 21.2 [6.21] 3.3	33.1 [9.70] 19.2 [5.63] 3.2	32.8 [9.61] 28.7 [8.41] 3.3	31.7 [9.29] 26.2 [7.68] 3.3	30.5 [8.94] 23.8 [6.98] 3.2	30.0 [8.79] 30.0 [8.79] 3.3	28.9 [8.47] 28.9 [8.47] 3.3	27.9 [8.18] 27.1 [7.94] 3.2
	115 [46.1]	Total BTUH [kW] Sens BTUH [kW] Power	34.2 [10.02] 22.5 [6.59] 3.5	33.0 [9.67] 20.5 [6.01] 3.4	31.8 [9.32] 18.6 [5.45] 3.4	31.4 [9.20] 28.0 [8.21] 3.4	30.3 [8.88] 25.6 [7.50] 3.4	29.2 [8.56] 23.2 [6.80] 3.3	28.6 [8.38] 28.6 [8.38] 3.5	27.6 [8.09] 27.6 [8.09] 3.4	26.6 [7.80] 26.5 [7.77] 3.3

GROSS SYSTEMS PERFORMANCE DATA—RQPM-A037

		ENTERING INDOOR AIR @ 80°F [26.7°C] dbE ①									
wbE		71°F [21.7°C]			67°F [19.4°C]			63°F [17.2°C]			
CFM [L/s]		1440 [680]	1200 [566]	960 [453]	1440 [680]	1200 [566]	960 [453]	1440 [680]	1200 [566]	960 [453]	
DR ①		.03	.06	.09	.03	.06	.09	.03	.06	.09	
OUTDOOR DRY BULB TEMPERATURE °F [°C]	75 [23.9]	Total BTUH [kW] Sens BTUH [kW] Power	7.3 [2.1] 0.1 [0.0] 2.4	7.1 [2.1] 0.1 [0.0] 2.3	6.8 [2.0] 0.1 [0.0] 2.3	8.8 [2.6] 0.1 [0.0] 2.4	8.5 [2.5] 0.1 [0.0] 2.3	8.2 [2.4] 0.1 [0.0] 2.3	3.0 [0.9] 0.1 [0.0] 2.3	2.9 [0.8] 0.1 [0.0] 2.3	2.8 [0.8] 0.1 [0.0] 2.3
	80 [26.7]	Total BTUH [kW] Sens BTUH [kW] Power	18.3 [5.4] 1.0 [0.3] 2.5	17.7 [5.2] 0.3 [0.1] 2.5	17.0 [5.0] 0.1 [0.0] 2.4	19.8 [5.8] 10.8 [3.2] 2.5	19.1 [5.6] 9.2 [2.7] 2.4	18.4 [5.4] 7.7 [2.3] 2.4	14.0 [4.1] 10.4 [3.1] 2.5	13.5 [4.0] 9.0 [2.6] 2.4	13.0 [3.8] 7.7 [2.3] 2.4
	85 [29.4]	Total BTUH [kW] Sens BTUH [kW] Power	26.8 [7.9] 10.9 [3.2] 2.6	25.8 [7.6] 9.0 [2.6] 2.6	24.9 [7.3] 7.3 [2.1] 2.5	28.2 [8.3] 20.8 [6.1] 2.6	27.2 [8.0] 18.0 [5.3] 2.6	26.2 [7.7] 15.4 [4.5] 2.5	22.4 [6.6] 20.2 [5.9] 2.6	21.7 [6.4] 17.8 [5.2] 2.6	20.9 [6.1] 15.4 [4.5] 2.5
	90 [32.2]	Total BTUH [kW] Sens BTUH [kW] Power	32.6 [9.6] 18.0 [5.3] 2.8	31.5 [9.2] 15.4 [4.5] 2.7	30.3 [8.9] 12.9 [3.8] 2.7	34.1 [10.0] 28.0 [8.2] 2.8	32.9 [9.6] 24.4 [7.2] 2.7	31.7 [9.3] 21.0 [6.2] 2.7	28.3 [8.3] 27.4 [8.0] 2.7	27.3 [8.0] 24.1 [7.1] 2.7	26.3 [7.7] 20.9 [6.1] 2.6
	95 [35]	Total BTUH [kW] Sens BTUH [kW] Power	36.0 [10.6] 22.6 [6.6] 2.9	34.7 [10.2] 19.4 [5.7] 2.9	33.4 [9.8] 16.4 [4.8] 2.8	37.4 [11.0] 32.4 [9.5] 2.9	36.1 [10.6] 28.3 [8.3] 2.9	34.8 [10.2] 24.5 [7.2] 2.8	31.6 [9.3] 31.6 [9.3] 2.9	30.5 [8.9] 28.1 [8.2] 2.8	29.4 [8.6] 24.5 [7.2] 2.8
	100 [37.8]	Total BTUH [kW] Sens BTUH [kW] Power	36.7 [10.8] 24.2 [7.1] 3.1	35.4 [10.4] 20.8 [6.1] 3.0	34.1 [10.0] 17.7 [5.2] 3.0	38.2 [11.2] 34.1 [10.0] 3.1	36.8 [10.8] 29.8 [8.7] 3.0	35.5 [10.4] 25.8 [7.6] 3.0	32.4 [9.5] 32.4 [9.5] 3.0	31.3 [9.2] 29.6 [8.7] 3.0	30.1 [8.8] 25.7 [7.5] 2.9
	105 [40.6]	Total BTUH [kW] Sens BTUH [kW] Power	34.9 [10.2] 23.1 [6.8] 3.2	33.7 [9.9] 19.9 [5.8] 3.2	32.5 [9.5] 17.0 [5.0] 3.1	36.4 [10.7] 33.0 [9.7] 3.2	35.1 [10.3] 28.9 [8.5] 3.2	33.8 [9.9] 25.0 [7.3] 3.1	30.6 [9.0] 30.6 [9.0] 3.2	29.5 [8.6] 28.6 [8.4] 3.1	28.5 [8.4] 25.0 [7.3] 3.1
	110 [43.3]	Total BTUH [kW] Sens BTUH [kW] Power	30.6 [9.0] 19.4 [5.7] 3.4	29.5 [8.6] 16.6 [4.9] 3.3	28.4 [8.3] 14.1 [4.1] 3.3	32.0 [9.4] 29.1 [8.5] 3.4	30.9 [9.1] 25.5 [7.5] 3.3	29.8 [8.7] 22.1 [6.5] 3.3	26.3 [7.7] 26.3 [7.7] 3.4	25.4 [7.4] 25.4 [7.5] 3.3	24.4 [7.2] 22.1 [6.5] 3.3
	115 [46.1]	Total BTUH [kW] Sens BTUH [kW] Power	23.7 [6.9] 12.7 [3.7] 3.6	22.9 [6.7] 10.8 [3.2] 3.5	22.0 [6.4] 9.0 [2.6] 3.5	25.1 [7.4] 22.5 [6.6] 3.6	24.2 [7.1] 19.7 [5.8] 3.5	23.4 [6.9] 17.1 [5.0] 3.4	19.4 [5.7] 19.4 [5.7] 3.6	18.7 [5.5] 18.7 [5.5] 3.5	18.0 [5.3] 17.0 [5.0] 3.4

DR —Depression ratio
dbE—Entering air dry bulb
wbE—Entering air wet bulb

Total —Total capacity x 1000 BTUH
Sens —Sensible capacity x 1000 BTUH
Power—KW input

NOTES: ① When the entering air dry bulb is other than 80°F [27°C], adjust the sensible capacity from the table by adding $[1.10 \times \text{CFM} \times (1 - \text{DR}) \times (\text{dbE} - 80)]$.

[] Designates Metric Conversions



SYSTEMS PERFORMANCE—RQPM- SERIES

GROSS SYSTEMS PERFORMANCE DATA—RQPM-042

		ENTERING INDOOR AIR @ 80°F [26.7°C] dbE ①									
wbE		71°F [21.7°C]			67°F [19.4°C]			63°F [17.2°C]			
CFM [L/s]		1740 [821]	1450 [684]	1160 [547]	1740 [821]	1450 [684]	1160 [547]	1740 [821]	1450 [684]	1160 [547]	
DR ①		.21	.18	.14	.21	.18	.14	.21	.18	.14	
OUTDOOR DRY BULB TEMPERATURE °F [°C]	75 [23.9]	Total BTUH [kW] Sens BTUH [kW] Power	52.5 [15.39] 31.7 [9.29] 2.8	50.7 [14.86] 29.0 [8.50] 2.7	48.8 [14.30] 26.3 [7.71] 2.7	50.4 [14.77] 38.2 [11.20] 2.7	48.7 [14.27] 34.9 [10.23] 2.7	46.9 [13.75] 31.7 [9.29] 2.7	47.1 [13.80] 43.4 [12.72] 2.7	45.5 [13.33] 39.7 [11.63] 2.7	43.8 [12.84] 36.0 [10.55] 2.6
	80 [26.7]	Total BTUH [kW] Sens BTUH [kW] Power	51.6 [15.12] 31.2 [9.14] 2.9	49.8 [14.59] 28.5 [8.35] 2.9	48.0 [14.07] 25.9 [7.59] 2.8	49.5 [14.51] 37.7 [11.05] 2.9	47.8 [14.01] 34.5 [10.11] 2.9	46.0 [13.48] 31.3 [9.17] 2.8	46.2 [13.54] 42.9 [12.57] 2.9	44.6 [13.07] 39.3 [11.52] 2.9	43.0 [12.60] 35.6 [10.43] 2.8
	85 [29.4]	Total BTUH [kW] Sens BTUH [kW] Power	50.4 [14.77] 30.6 [8.97] 3.1	48.7 [14.27] 28.0 [8.21] 3.1	46.9 [13.75] 25.4 [7.44] 3.0	48.3 [14.16] 37.1 [10.87] 3.1	46.6 [13.66] 33.9 [9.94] 3.0	44.9 [13.16] 30.8 [9.03] 3.0	45.0 [13.19] 42.3 [12.40] 3.1	43.4 [12.72] 38.7 [11.34] 3.0	41.9 [12.28] 35.1 [10.29] 3.0
	90 [32.2]	Total BTUH [kW] Sens BTUH [kW] Power	49.0 [14.36] 29.9 [8.76] 3.3	47.3 [13.86] 27.4 [8.03] 3.2	45.6 [13.36] 24.8 [7.27] 3.2	47.0 [13.77] 36.4 [10.67] 3.3	45.3 [13.28] 33.3 [9.76] 3.2	43.7 [12.81] 30.2 [8.85] 3.2	43.6 [12.78] 41.6 [12.19] 3.2	42.1 [12.34] 38.1 [11.17] 3.2	40.6 [11.90] 34.5 [10.11] 3.1
	95 [35]	Total BTUH [kW] Sens BTUH [kW] Power	47.5 [13.92] 29.2 [8.56] 3.5	45.8 [13.42] 26.7 [7.83] 3.4	44.2 [12.95] 24.2 [7.09] 3.3	45.4 [13.31] 35.7 [10.46] 3.4	43.8 [12.84] 32.6 [9.55] 3.4	42.2 [12.37] 29.6 [8.67] 3.3	42.1 [12.34] 41.0 [12.02] 3.4	40.6 [11.90] 37.4 [10.96] 3.4	39.1 [11.46] 33.9 [9.94] 3.3
	100 [37.8]	Total BTUH [kW] Sens BTUH [kW] Power	45.9 [13.45] 28.4 [8.32] 3.6	44.3 [12.98] 26.0 [7.62] 3.6	42.7 [12.51] 23.5 [6.89] 3.5	43.8 [12.84] 34.9 [10.23] 3.6	42.2 [12.37] 31.9 [9.35] 3.6	40.7 [11.93] 28.9 [8.47] 3.5	40.5 [11.87] 40.0 [11.72] 3.6	39.0 [11.43] 36.7 [10.76] 3.5	37.6 [11.02] 33.3 [9.76] 3.5
	105 [40.6]	Total BTUH [kW] Sens BTUH [kW] Power	44.2 [12.95] 27.6 [8.09] 3.8	42.6 [12.48] 25.3 [7.41] 3.7	41.1 [12.05] 22.9 [6.71] 3.7	42.1 [12.34] 34.1 [9.99] 3.8	40.6 [11.90] 31.2 [9.14] 3.7	39.2 [11.49] 28.3 [8.29] 3.7	38.8 [11.37] 38.8 [11.37] 3.8	37.4 [10.96] 36.0 [10.55] 3.7	36.1 [10.58] 32.6 [9.55] 3.6
	110 [43.3]	Total BTUH [kW] Sens BTUH [kW] Power	42.5 [12.46] 26.9 [7.88] 4.0	41.0 [12.02] 24.6 [7.21] 3.9	39.6 [11.61] 22.3 [6.54] 3.8	40.4 [11.84] 33.4 [9.79] 4.0	39.0 [11.43] 30.5 [8.94] 3.9	37.6 [11.02] 27.7 [8.12] 3.8	37.1 [10.87] 37.1 [10.87] 3.9	35.8 [10.49] 35.3 [10.35] 3.9	34.5 [10.11] 32.0 [9.38] 3.8
	115 [46.1]	Total BTUH [kW] Sens BTUH [kW] Power	41.0 [12.02] 26.2 [7.68] 4.2	39.5 [11.58] 24.0 [7.03] 4.1	38.1 [11.17] 21.8 [6.39] 4.0	38.9 [11.40] 32.7 [9.58] 4.1	37.5 [10.99] 30.0 [8.79] 4.1	36.1 [10.58] 27.2 [7.97] 4.0	35.5 [10.40] 35.5 [10.40] 4.1	34.3 [10.05] 34.3 [10.05] 4.1	33.0 [9.67] 31.5 [9.23] 4.0

GROSS SYSTEMS PERFORMANCE DATA—RQPM-A048

		ENTERING INDOOR AIR @ 80°F [26.7°C] dbE ①									
wbE		71°F [21.7°C]			67°F [19.4°C]			63°F [17.2°C]			
CFM [L/s]		1860 [878]	1550 [732]	1240 [585]	1860 [878]	1550 [732]	1240 [585]	1860 [878]	1550 [732]	1240 [585]	
DR ①		.12	.09	.04	.12	.09	.04	.12	.09	.04	
OUTDOOR DRY BULB TEMPERATURE °F [°C]	75 [23.9]	Total BTUH [kW] Sens BTUH [kW] Power	60.3 [17.67] 37.2 [10.90] 3.1	58.2 [17.06] 34.1 [9.99] 3.1	56.1 [16.44] 30.9 [9.06] 3.0	57.0 [16.71] 44.2 [12.95] 3.1	55.0 [16.12] 40.4 [11.84] 3.1	53.0 [15.53] 36.7 [10.76] 3.0	52.9 [15.50] 52.2 [15.30] 3.1	51.0 [14.95] 47.6 [13.95] 3.0	49.2 [14.42] 43.3 [12.69] 3.0
	80 [26.7]	Total BTUH [kW] Sens BTUH [kW] Power	59.2 [17.35] 36.8 [10.79] 3.3	57.1 [16.73] 33.6 [9.85] 3.3	55.0 [16.12] 30.5 [8.94] 3.2	55.8 [16.35] 43.8 [12.84] 3.3	53.9 [15.80] 40.0 [11.72] 3.2	51.9 [15.21] 36.3 [10.64] 3.2	51.7 [15.15] 51.7 [15.15] 3.3	49.9 [14.62] 47.5 [13.92] 3.2	48.1 [14.10] 42.9 [12.57] 3.2
	85 [29.4]	Total BTUH [kW] Sens BTUH [kW] Power	57.7 [16.91] 36.1 [10.58] 3.5	55.6 [16.29] 33.0 [9.67] 3.4	53.6 [15.71] 29.9 [8.76] 3.4	54.4 [15.94] 43.1 [12.63] 3.5	52.4 [15.36] 39.4 [11.55] 3.4	50.5 [14.80] 35.7 [10.46] 3.4	50.2 [14.71] 50.2 [14.71] 3.5	48.4 [14.18] 46.9 [13.75] 3.4	46.7 [13.69] 42.3 [12.40] 3.4
	90 [32.2]	Total BTUH [kW] Sens BTUH [kW] Power	55.9 [16.38] 35.2 [10.32] 3.7	54.0 [15.83] 32.2 [9.44] 3.6	52.0 [15.24] 29.2 [8.56] 3.6	52.6 [15.42] 42.2 [12.37] 3.7	50.8 [14.89] 38.6 [11.31] 3.6	48.9 [14.33] 35.0 [10.26] 3.6	48.5 [14.21] 48.5 [14.21] 3.7	46.8 [13.72] 45.9 [13.45] 3.6	45.1 [13.22] 41.6 [12.19] 3.6
	95 [35]	Total BTUH [kW] Sens BTUH [kW] Power	54.0 [15.83] 34.3 [10.05] 3.9	52.2 [15.30] 31.4 [9.20] 3.8	50.3 [14.74] 28.4 [8.32] 3.8	50.7 [14.86] 41.3 [12.10] 3.9	49.0 [14.36] 37.8 [11.08] 3.8	47.2 [13.83] 34.2 [10.02] 3.8	46.6 [13.66] 46.6 [13.66] 3.9	45.0 [13.19] 45.0 [13.19] 3.8	43.3 [12.69] 40.8 [11.96] 3.7
	100 [37.8]	Total BTUH [kW] Sens BTUH [kW] Power	52.1 [15.27] 33.3 [9.76] 4.1	50.3 [14.74] 30.4 [8.91] 4.0	48.4 [14.18] 27.6 [8.09] 4.0	48.8 [14.30] 40.3 [11.81] 4.1	47.1 [13.80] 36.8 [10.79] 4.0	45.4 [13.31] 33.4 [9.79] 3.9	44.6 [13.07] 44.6 [13.07] 4.1	43.1 [12.63] 43.1 [12.63] 4.0	41.5 [12.16] 40.0 [11.72] 3.9
	105 [40.6]	Total BTUH [kW] Sens BTUH [kW] Power	50.2 [14.71] 32.3 [9.47] 4.3	48.4 [14.18] 29.5 [8.65] 4.2	46.7 [13.69] 26.8 [7.85] 4.1	46.9 [13.75] 39.3 [11.52] 4.3	45.2 [13.25] 35.9 [10.52] 4.2	43.6 [12.78] 32.6 [9.55] 4.1	42.7 [12.51] 42.7 [12.51] 4.3	41.2 [12.07] 41.2 [12.07] 4.2	39.7 [11.63] 39.2 [11.49] 4.1
	110 [43.3]	Total BTUH [kW] Sens BTUH [kW] Power	48.3 [14.16] 31.3 [9.17] 4.5	46.6 [13.66] 28.7 [8.41] 4.4	45.0 [13.19] 26.0 [7.62] 4.3	45.0 [13.19] 38.3 [11.22] 4.5	43.5 [12.75] 35.1 [10.29] 4.4	41.9 [12.28] 31.8 [9.32] 4.3	40.9 [11.99] 40.9 [11.99] 4.5	39.4 [11.55] 39.4 [11.55] 4.4	38.0 [11.14] 38.0 [11.14] 4.3
	115 [46.1]	Total BTUH [kW] Sens BTUH [kW] Power	46.7 [13.69] 30.5 [8.94] 4.7	45.1 [13.22] 27.9 [8.18] 4.6	43.4 [12.72] 25.3 [7.41] 4.5	43.4 [12.72] 37.5 [10.99] 4.7	41.9 [12.28] 34.3 [10.05] 4.6	40.3 [11.81] 31.1 [9.11] 4.5	39.2 [11.49] 39.2 [11.49] 4.6	37.9 [11.11] 37.9 [11.11] 4.6	36.5 [10.70] 36.5 [10.70] 4.5

DR —Depression ratio
dbE—Entering air dry bulb
wbE—Entering air wet bulb

Total —Total capacity x 1000 BTUH
Sens —Sensible capacity x 1000 BTUH
Power—KW input

NOTES: ① When the entering air dry bulb is other than 80°F [27°C], adjust the sensible capacity from the table by adding [1.10 x CFM x (1 - DR) x (dbE - 80)].

[] Designates Metric Conversions

SYSTEMS PERFORMANCE—RQPM- SERIES



GROSS SYSTEMS PERFORMANCE DATA—RQPM-A049CK

		ENTERING INDOOR AIR @ 80°F [26.7°C] dbE ①									
wbE		71°F [21.7°C]			67°F [19.4°C]			63°F [17.2°C]			
CFM [L/s]		1860 [878]	1550 [732]	1240 [585]	1860 [878]	1550 [732]	1240 [585]	1860 [878]	1550 [732]	1240 [585]	
DR ①		.01	.05	.09	.01	.05	.09	.01	.05	.09	
OUTDOOR DRY BULB TEMPERATURE °F [°C]	75 [23.9]	Total BTUH [kW] Sens BTUH [kW] Power	60.4 [17.7] 38.0 [11.1] 3.0	58.3 [17.1] 32.7 [9.6] 3.0	56.1 [16.4] 27.7 [8.1] 2.9	57.1 [16.7] 45.7 [13.4] 3.0	55.1 [16.1] 39.8 [11.7] 3.0	53.1 [15.6] 34.3 [10.1] 2.9	52.9 [15.5] 49.4 [14.5] 3.0	51.1 [15.0] 43.4 [12.7] 3.0	49.2 [14.4] 37.6 [11.0] 2.9
	80 [26.7]	Total BTUH [kW] Sens BTUH [kW] Power	58.9 [17.3] 37.6 [11.0] 3.2	56.8 [16.6] 32.3 [9.5] 3.1	54.8 [16.1] 27.5 [8.1] 3.1	55.6 [16.3] 45.4 [13.3] 3.2	53.7 [15.7] 39.6 [11.6] 3.1	51.7 [15.2] 34.1 [10.0] 3.1	51.4 [15.1] 49.0 [14.4] 3.2	49.6 [14.5] 43.0 [12.6] 3.1	47.8 [14.0] 37.4 [11.0] 3.1
	85 [29.4]	Total BTUH [kW] Sens BTUH [kW] Power	57.3 [16.8] 37.0 [10.9] 3.4	55.3 [16.2] 31.8 [9.3] 3.3	53.3 [15.6] 27.0 [7.9] 3.3	54.1 [15.9] 44.8 [13.1] 3.4	52.2 [15.3] 39.1 [11.5] 3.3	50.3 [14.7] 33.7 [9.9] 3.3	49.9 [14.6] 48.4 [14.2] 3.4	48.1 [14.1] 42.5 [12.5] 3.3	46.4 [13.6] 37.0 [10.9] 3.2
	90 [32.2]	Total BTUH [kW] Sens BTUH [kW] Power	55.7 [16.3] 36.3 [10.6] 3.6	53.7 [15.7] 31.2 [9.2] 3.5	51.8 [15.2] 26.6 [7.8] 3.5	52.4 [15.4] 44.1 [12.9] 3.6	50.6 [14.8] 38.5 [11.3] 3.5	48.7 [14.3] 33.2 [9.7] 3.5	48.2 [14.1] 47.7 [14.0] 3.6	46.5 [13.6] 41.9 [12.3] 3.5	44.8 [13.1] 36.4 [10.7] 3.4
	95 [35]	Total BTUH [kW] Sens BTUH [kW] Power	54.0 [15.8] 35.4 [10.4] 3.8	52.1 [15.3] 30.5 [8.9] 3.7	50.2 [14.7] 25.9 [7.6] 3.7	50.7 [14.9] 43.2 [12.7] 3.8	49.0 [14.4] 37.8 [11.1] 3.7	47.2 [13.8] 32.6 [9.6] 3.7	46.5 [13.6] 46.5 [13.6] 3.8	44.9 [13.2] 41.2 [12.1] 3.7	43.3 [12.7] 35.9 [10.5] 3.6
	100 [37.8]	Total BTUH [kW] Sens BTUH [kW] Power	52.2 [15.3] 34.3 [10.1] 4.0	50.4 [14.8] 29.6 [8.7] 3.9	48.6 [14.2] 25.2 [7.4] 3.9	49.0 [14.4] 42.2 [12.4] 4.0	47.3 [13.9] 36.9 [10.8] 3.9	45.5 [13.3] 31.8 [9.3] 3.9	44.8 [13.1] 44.8 [13.1] 4.0	43.2 [12.7] 40.3 [11.8] 3.9	41.6 [12.2] 35.1 [10.3] 3.9
	105 [40.6]	Total BTUH [kW] Sens BTUH [kW] Power	50.4 [14.8] 33.2 [9.7] 4.3	48.7 [14.3] 28.7 [8.4] 4.2	46.9 [13.7] 24.4 [7.2] 4.1	47.2 [13.8] 41.1 [12.1] 4.2	45.5 [13.3] 35.9 [10.5] 4.2	43.8 [12.8] 31.0 [9.1] 4.1	43.0 [12.6] 43.0 [12.6] 4.2	41.5 [12.2] 39.4 [11.6] 4.2	39.9 [11.7] 34.3 [10.1] 4.1
	110 [43.3]	Total BTUH [kW] Sens BTUH [kW] Power	48.5 [14.2] 31.8 [9.3] 4.5	46.8 [13.7] 27.4 [8.0] 4.4	45.1 [13.2] 23.3 [6.8] 4.3	45.3 [13.3] 39.7 [11.6] 4.5	43.7 [12.8] 34.7 [10.2] 4.4	42.1 [12.3] 30.0 [8.8] 4.3	41.1 [12.0] 41.1 [12.1] 4.5	39.6 [11.6] 38.2 [11.2] 4.4	38.2 [11.2] 33.4 [9.8] 4.3
	115 [46.1]	Total BTUH [kW] Sens BTUH [kW] Power	46.6 [13.7] 30.4 [8.9] 4.8	45.0 [13.2] 26.2 [7.7] 4.7	43.3 [12.7] 22.2 [6.5] 4.6	43.3 [12.7] 38.2 [11.2] 4.7	41.8 [12.3] 33.4 [9.8] 4.7	40.3 [11.8] 28.9 [8.5] 4.6	39.1 [11.5] 39.1 [11.5] 4.7	37.7 [11.0] 36.8 [10.8] 4.7	36.4 [10.7] 32.2 [9.4] 4.6

GROSS SYSTEMS PERFORMANCE DATA—RQPM-A049JK

		ENTERING INDOOR AIR @ 80°F [26.7°C] dbE ①									
wbE		71°F [21.7°C]			67°F [19.4°C]			63°F [17.2°C]			
CFM [L/s]		1860 [878]	1550 [732]	1240 [585]	1860 [878]	1550 [732]	1240 [585]	1860 [878]	1550 [732]	1240 [585]	
DR ①		.01	.05	.09	.01	.05	.09	.01	.05	.09	
OUTDOOR DRY BULB TEMPERATURE °F [°C]	75 [23.9]	Total BTUH [kW] Sens BTUH [kW] Power	58.7 [17.2] 37.2 [10.9] 3.0	56.6 [16.6] 31.9 [9.4] 3.0	54.6 [16.0] 27.1 [8.0] 2.9	56.4 [16.5] 45.4 [13.3] 3.0	54.4 [15.9] 39.5 [11.6] 3.0	52.4 [15.4] 34.0 [10.0] 2.9	52.5 [15.4] 49.3 [14.5] 3.0	50.7 [14.9] 43.3 [12.7] 2.9	48.9 [14.3] 37.6 [11.0] 2.9
	80 [26.7]	Total BTUH [kW] Sens BTUH [kW] Power	57.6 [16.9] 37.0 [10.9] 3.2	55.6 [16.3] 31.8 [9.3] 3.2	53.6 [15.7] 27.0 [7.9] 3.1	55.3 [16.2] 45.2 [13.3] 3.2	53.4 [15.6] 39.4 [11.6] 3.1	51.4 [15.1] 33.9 [9.9] 3.1	51.5 [15.1] 49.1 [14.4] 3.2	49.7 [14.6] 43.1 [12.6] 3.1	47.9 [14.0] 37.4 [11.0] 3.0
	85 [29.4]	Total BTUH [kW] Sens BTUH [kW] Power	56.3 [16.5] 36.5 [10.7] 3.4	54.3 [15.9] 31.4 [9.2] 3.4	52.4 [15.4] 26.7 [7.8] 3.3	54.0 [15.8] 44.7 [13.1] 3.4	52.1 [15.3] 39.0 [11.4] 3.3	50.2 [14.7] 33.6 [9.9] 3.3	50.2 [14.7] 48.7 [14.3] 3.3	48.4 [14.2] 42.7 [12.5] 3.3	46.7 [13.7] 37.2 [10.9] 3.2
	90 [32.2]	Total BTUH [kW] Sens BTUH [kW] Power	54.8 [16.1] 35.9 [10.5] 3.6	52.9 [15.5] 30.9 [9.1] 3.5	50.9 [14.9] 26.2 [7.7] 3.5	52.5 [15.4] 44.1 [12.9] 3.6	50.7 [14.9] 38.5 [11.3] 3.5	48.8 [14.3] 33.2 [9.7] 3.5	48.7 [14.3] 48.0 [14.1] 3.5	46.9 [13.7] 42.1 [12.3] 3.5	45.2 [13.2] 36.6 [10.7] 3.4
	95 [35]	Total BTUH [kW] Sens BTUH [kW] Power	53.0 [15.5] 35.0 [10.3] 3.8	51.2 [15.0] 30.2 [8.9] 3.8	49.3 [14.4] 25.7 [7.5] 3.7	50.7 [14.9] 43.2 [12.7] 3.8	49.0 [14.4] 37.8 [11.1] 3.7	47.2 [13.8] 32.6 [9.6] 3.7	46.9 [13.7] 46.9 [13.8] 3.8	45.2 [13.2] 41.4 [12.1] 3.7	43.6 [12.8] 36.1 [10.6] 3.6
	100 [37.8]	Total BTUH [kW] Sens BTUH [kW] Power	51.0 [14.9] 33.9 [9.9] 4.0	49.2 [14.4] 29.2 [8.6] 4.0	47.4 [13.9] 24.8 [7.3] 3.9	48.7 [14.3] 42.1 [12.3] 4.0	47.0 [13.8] 36.8 [10.8] 3.9	45.3 [13.3] 31.8 [9.3] 3.9	44.9 [13.2] 44.9 [13.2] 4.0	43.3 [12.7] 40.5 [11.9] 3.9	41.7 [12.2] 35.3 [10.4] 3.8
	105 [40.6]	Total BTUH [kW] Sens BTUH [kW] Power	48.8 [14.3] 32.7 [9.6] 4.3	47.1 [13.8] 28.2 [8.3] 4.2	45.4 [13.3] 24.0 [7.0] 4.1	46.5 [13.6] 40.9 [12.0] 4.2	44.9 [13.2] 35.8 [10.5] 4.2	43.3 [12.7] 31.0 [9.1] 4.1	42.7 [12.5] 42.7 [12.5] 4.2	41.2 [12.1] 39.5 [11.6] 4.1	39.7 [11.6] 34.5 [10.1] 4.1
	110 [43.3]	Total BTUH [kW] Sens BTUH [kW] Power	46.3 [13.6] 31.2 [9.2] 4.5	44.7 [13.1] 26.9 [7.9] 4.4	43.1 [12.6] 22.9 [6.7] 4.4	44.1 [12.9] 39.5 [11.6] 4.5	42.5 [12.5] 34.5 [10.1] 4.4	41.0 [12.0] 29.9 [8.8] 4.3	40.2 [11.8] 40.2 [11.8] 4.5	38.8 [11.4] 38.2 [11.2] 4.4	37.4 [11.0] 33.4 [9.8] 4.3
	115 [46.1]	Total BTUH [kW] Sens BTUH [kW] Power	43.6 [12.8] 29.4 [8.6] 4.8	42.1 [12.3] 25.4 [7.5] 4.7	40.6 [11.9] 21.7 [6.4] 4.6	41.4 [12.1] 37.7 [11.1] 4.7	39.9 [11.7] 33.0 [9.7] 4.7	38.5 [11.3] 28.7 [8.4] 4.6	37.5 [11.0] 37.5 [11.0] 4.7	36.2 [10.6] 36.2 [10.6] 4.6	34.9 [10.2] 32.2 [9.4] 4.5

DR —Depression ratio
dbE—Entering air dry bulb
wbE—Entering air wet bulb

Total —Total capacity x 1000 BTUH
Sens —Sensible capacity x 1000 BTUH
Power—KW input

NOTES: ① When the entering air dry bulb is other than 80°F [27°C], adjust the sensible capacity from the table by adding [1.10 x CFM x (1 - DR) x (dbE - 80)].

[] Designates Metric Conversions



SYSTEMS PERFORMANCE—RQPM- SERIES

GROSS SYSTEMS PERFORMANCE DATA—RQPM-A060

		ENTERING INDOOR AIR @ 80°F [26.7°C] dbE ①									
wbE		71°F [21.7°C]			67°F [19.4°C]			63°F [17.2°C]			
CFM [L/s]		2280 [1076]	1900 [897]	1520 [717]	2280 [1076]	1900 [897]	1520 [717]	2280 [1076]	1900 [897]	1520 [717]	
DR ①		.11	.08	.03	.11	.08	.03	.11	.08	.03	
OUTDOOR DRY BULB TEMPERATURE °F [°C]	75 [23.9]	Total BTUH [kW] Sens BTUH [kW] Power	78.4 [22.98] 48.3 [14.16] 3.7	75.7 [22.19] 44.2 [12.95] 3.6	72.9 [21.36] 40.0 [11.72] 3.6	72.6 [21.28] 56.6 [16.59] 3.7	70.1 [20.54] 51.7 [15.15] 3.6	67.5 [19.78] 46.9 [13.75] 3.5	69.8 [20.46] 65.4 [19.17] 3.6	67.4 [19.75] 59.8 [17.53] 3.6	64.9 [19.02] 54.2 [15.88] 3.5
	80 [26.7]	Total BTUH [kW] Sens BTUH [kW] Power	76.1 [22.30] 46.4 [13.60] 3.9	73.4 [21.51] 42.5 [12.46] 3.9	70.7 [20.72] 38.5 [11.28] 3.8	70.3 [20.60] 54.7 [16.03] 3.9	67.8 [19.87] 50.0 [14.65] 3.8	65.3 [19.14] 45.4 [13.31] 3.8	67.5 [19.78] 63.4 [18.58] 3.8	65.1 [19.08] 58.1 [17.03] 3.8	62.7 [18.38] 52.7 [15.44] 3.7
	85 [29.4]	Total BTUH [kW] Sens BTUH [kW] Power	73.7 [21.60] 45.0 [13.19] 4.1	71.2 [20.87] 41.2 [12.07] 4.1	68.6 [20.10] 37.3 [10.93] 4.0	68.0 [19.93] 53.3 [15.62] 4.1	65.6 [19.23] 48.8 [14.30] 4.1	63.2 [18.52] 44.2 [12.95] 4.0	65.2 [19.11] 62.4 [18.29] 4.1	62.9 [18.43] 56.8 [16.65] 4.0	60.6 [17.76] 51.5 [15.09] 3.9
	90 [32.2]	Total BTUH [kW] Sens BTUH [kW] Power	71.5 [20.95] 43.9 [12.87] 4.4	69.0 [20.22] 40.2 [11.78] 4.3	66.4 [19.46] 36.4 [10.67] 4.2	65.7 [19.25] 52.2 [15.30] 4.3	63.4 [18.58] 47.8 [14.01] 4.3	61.1 [17.91] 43.3 [12.69] 4.2	62.9 [18.43] 61.2 [17.94] 4.3	60.7 [17.79] 55.9 [16.38] 4.2	58.5 [17.14] 50.6 [14.83] 4.2
	95 [35]	Total BTUH [kW] Sens BTUH [kW] Power	69.2 [20.28] 43.1 [12.63] 4.6	66.8 [19.58] 39.4 [11.55] 4.5	64.4 [18.87] 35.7 [10.46] 4.4	63.4 [18.58] 51.4 [15.06] 4.6	61.2 [17.94] 47.0 [13.77] 4.5	59.0 [17.29] 42.6 [12.48] 4.4	60.6 [17.76] 59.9 [17.55] 4.5	58.5 [17.14] 55.1 [16.15] 4.5	56.4 [16.53] 49.9 [14.62] 4.4
	100 [37.8]	Total BTUH [kW] Sens BTUH [kW] Power	67.1 [19.67] 42.4 [12.43] 4.8	64.7 [18.96] 38.8 [11.37] 4.7	62.4 [18.29] 35.1 [10.29] 4.7	61.3 [17.97] 50.7 [14.86] 4.8	59.1 [17.32] 46.3 [13.57] 4.7	57.0 [16.71] 42.0 [12.31] 4.6	58.5 [17.14] 58.5 [17.14] 4.8	56.4 [16.53] 54.4 [15.94] 4.7	54.4 [15.94] 49.3 [14.45] 4.6
	105 [40.6]	Total BTUH [kW] Sens BTUH [kW] Power	65.0 [19.05] 41.7 [12.22] 5.1	62.7 [18.38] 38.1 [11.17] 5.0	60.4 [17.70] 34.5 [10.11] 4.9	59.2 [17.35] 50.0 [14.65] 5.0	57.1 [16.73] 45.7 [13.39] 4.9	55.1 [16.15] 41.4 [12.13] 4.9	56.4 [16.53] 56.4 [16.53] 5.0	54.4 [15.94] 53.8 [15.77] 4.9	52.5 [15.39] 48.8 [14.30] 4.8
	110 [43.3]	Total BTUH [kW] Sens BTUH [kW] Power	63.0 [18.46] 40.9 [11.99] 5.3	60.8 [17.82] 37.4 [10.96] 5.2	58.6 [17.17] 33.9 [9.94] 5.1	57.3 [16.79] 49.2 [14.42] 5.3	55.2 [16.18] 45.0 [13.19] 5.2	53.2 [15.59] 40.8 [11.96] 5.1	54.5 [15.97] 54.5 [15.97] 5.2	52.6 [15.42] 52.6 [15.42] 5.1	50.6 [14.83] 48.1 [14.10] 5.0
	115 [46.1]	Total BTUH [kW] Sens BTUH [kW] Power	61.2 [17.94] 39.9 [11.69] 5.5	59.1 [17.32] 36.5 [10.70] 5.4	56.9 [16.68] 33.1 [9.70] 5.3	55.4 [16.24] 48.2 [14.13] 5.5	53.5 [15.68] 44.1 [12.92] 5.4	51.5 [15.09] 39.9 [11.69] 5.3	52.6 [15.42] 52.6 [15.42] 5.4	50.8 [14.89] 50.8 [14.89] 5.4	48.9 [14.33] 47.3 [13.86] 5.3

DR —Depression ratio
dbE—Entering air dry bulb
wbE—Entering air wet bulb

Total —Total capacity x 1000 BTUH
Sens —Sensible capacity x 1000 BTUH
Power—KW input

NOTES: ① When the entering air dry bulb is other than 80°F [27°C], adjust the sensible capacity from the table by adding [1.10 x CFM x (1 - DR) x (dbE - 80)].

[] Designates Metric Conversions



HEATING PERFORMANCE DATA—RQNM-A024

IDB		60°F [15.5°C]			70°F [21.1°C]			80°F [26.7°C]			
CFM [L/s]		960 [453]	800 [378]	640 [302]	960 [453]	800 [378]	640 [302]	960 [453]	800 [378]	640 [302]	
OUTDOOR DRY BULB TEMPERATURE °F [°C]	0 [-17.8]	Total BTUH [kW] Power	7.6 [2.23] 1.3	7.5 [2.20] 1.3	7.4 [2.17] 1.3	6.8 [1.99] 1.4	6.7 [1.96] 1.5	6.6 [1.93] 1.5	5.7 [1.67] 1.6	5.7 [1.67] 1.7	5.6 [1.64] 1.7
	5 [-15]	Total BTUH [kW] Power	9.4 [2.75] 1.3	9.2 [2.70] 1.3	9.1 [2.67] 1.4	8.6 [2.52] 1.5	8.5 [2.49] 1.5	8.3 [2.43] 1.6	7.5 [2.20] 1.6	7.4 [2.17] 1.7	7.3 [2.14] 1.7
	10 [-12.2]	Total BTUH [kW] Power	11.1 [3.25] 1.3	11.0 [3.22] 1.4	10.8 [3.17] 1.4	10.3 [3.02] 1.5	10.2 [2.99] 1.5	10.1 [2.96] 1.6	9.3 [2.73] 1.7	9.1 [2.67] 1.7	9.0 [2.64] 1.8
	15 [-9.4]	Total BTUH [kW] Power	12.9 [3.78] 1.4	12.7 [3.72] 1.4	12.5 [3.66] 1.4	12.1 [3.55] 1.5	11.9 [3.49] 1.6	11.7 [3.43] 1.6	11.0 [3.22] 1.7	10.8 [3.17] 1.8	10.7 [3.14] 1.8
	20 [-6.7]	Total BTUH [kW] Power	14.6 [4.28] 1.4	14.4 [4.22] 1.4	14.2 [4.16] 1.5	13.8 [4.04] 1.6	13.6 [3.99] 1.6	13.4 [3.93] 1.7	12.7 [3.72] 1.7	12.5 [3.66] 1.8	12.4 [3.63] 1.8
	25 [-3.9]	Total BTUH [kW] Power	16.3 [4.78] 1.4	16.1 [4.72] 1.5	15.8 [4.63] 1.5	15.5 [4.54] 1.6	15.3 [4.48] 1.7	15.1 [4.43] 1.7	14.4 [4.22] 1.8	14.2 [4.16] 1.8	14.0 [4.10] 1.9
	30 [-1.1]	Total BTUH [kW] Power	18.0 [5.28] 1.5	17.7 [5.19] 1.5	17.5 [5.13] 1.5	17.2 [5.04] 1.6	16.9 [4.95] 1.7	16.7 [4.89] 1.7	16.1 [4.72] 1.8	15.9 [4.66] 1.9	15.7 [4.60] 1.9
	35 [1.7]	Total BTUH [kW] Power	19.6 [5.74] 1.5	19.4 [5.69] 1.5	19.1 [5.60] 1.6	18.9 [5.54] 1.7	18.6 [5.45] 1.7	18.3 [5.36] 1.8	17.8 [5.22] 1.8	17.5 [5.13] 1.9	17.3 [5.07] 1.9
	40 [4.4]	Total BTUH [kW] Power	21.3 [6.24] 1.5	21.0 [6.15] 1.6	20.7 [6.07] 1.6	20.5 [6.01] 1.7	20.2 [5.92] 1.8	19.9 [5.83] 1.8	19.4 [5.69] 1.9	19.2 [5.63] 1.9	18.9 [5.54] 2.0
	45 [7.2]	Total BTUH [kW] Power	22.9 [6.71] 1.6	22.6 [6.62] 1.6	22.3 [6.54] 1.6	22.1 [6.48] 1.7	21.8 [6.39] 1.8	21.5 [6.30] 1.8	21.1 [6.18] 1.9	20.8 [6.10] 2.0	20.5 [6.01] 2.0
50 [10]	Total BTUH [kW] Power	24.6 [7.21] 1.6	24.2 [7.09] 1.6	23.9 [7.00] 1.7	23.8 [6.98] 1.8	23.4 [6.86] 1.8	23.1 [6.77] 1.9	22.7 [6.65] 1.9	22.4 [6.56] 2.0	22.0 [6.45] 2.0	

IDB—Indoor air dry bulb

HEATING PERFORMANCE DATA—RQNM-A030

IDB		60°F [15.5°C]			70°F [21.1°C]			80°F [26.7°C]			
CFM [L/s]		1200 [566]	1000 [472]	800 [378]	1200 [566]	1000 [472]	800 [378]	1200 [566]	1000 [472]	800 [378]	
OUTDOOR DRY BULB TEMPERATURE °F [°C]	0 [-17.8]	Total BTUH [kW] Power	10.6 [3.11] 1.5	10.4 [3.05] 1.6	10.3 [3.02] 1.6	9.3 [2.73] 1.7	9.2 [2.70] 1.8	9.0 [2.64] 1.8	7.6 [2.23] 1.9	7.5 [2.20] 2.0	7.4 [2.17] 2.0
	5 [-15]	Total BTUH [kW] Power	12.1 [3.55] 1.6	11.9 [3.49] 1.6	11.7 [3.43] 1.6	10.8 [3.17] 1.8	10.7 [3.14] 1.8	10.5 [3.08] 1.8	9.2 [2.70] 2.0	9.0 [2.64] 2.0	8.9 [2.61] 2.1
	10 [-12.2]	Total BTUH [kW] Power	13.7 [4.02] 1.6	13.5 [3.96] 1.6	13.3 [3.90] 1.7	12.5 [3.66] 1.8	12.3 [3.60] 1.8	12.1 [3.55] 1.9	10.8 [3.17] 2.0	10.6 [3.11] 2.0	10.5 [3.08] 2.1
	15 [-9.4]	Total BTUH [kW] Power	15.5 [4.54] 1.6	15.3 [4.48] 1.7	15.0 [4.40] 1.7	14.2 [4.16] 1.8	14.0 [4.10] 1.9	13.8 [4.04] 1.9	12.6 [3.69] 2.0	12.4 [3.63] 2.1	12.2 [3.58] 2.1
	20 [-6.7]	Total BTUH [kW] Power	17.4 [5.10] 1.7	17.1 [5.01] 1.7	16.9 [4.95] 1.8	16.1 [4.72] 1.9	15.9 [4.66] 1.9	15.6 [4.57] 2.0	14.4 [4.22] 2.1	14.2 [4.16] 2.1	14.0 [4.10] 2.2
	25 [-3.9]	Total BTUH [kW] Power	19.3 [5.66] 1.7	19.1 [5.60] 1.8	18.8 [5.51] 1.8	18.1 [5.30] 1.9	17.8 [5.22] 2.0	17.6 [5.16] 2.0	16.4 [4.81] 2.1	16.2 [4.75] 2.2	15.9 [4.66] 2.2
	30 [-1.1]	Total BTUH [kW] Power	21.4 [6.27] 1.8	21.1 [6.18] 1.8	20.8 [6.10] 1.8	20.2 [5.92] 1.9	19.9 [5.83] 2.0	19.6 [5.74] 2.0	18.5 [5.42] 2.1	18.2 [5.33] 2.2	18.0 [5.28] 2.3
	35 [1.7]	Total BTUH [kW] Power	23.6 [6.92] 1.8	23.3 [6.83] 1.8	23.0 [6.74] 1.9	22.4 [6.56] 2.0	22.1 [6.48] 2.0	21.7 [6.36] 2.1	20.7 [6.07] 2.2	20.4 [5.98] 2.2	20.1 [5.89] 2.3
	40 [4.4]	Total BTUH [kW] Power	26.0 [7.62] 1.8	25.6 [7.50] 1.9	25.2 [7.39] 1.9	24.7 [7.24] 2.0	24.4 [7.15] 2.1	24.0 [7.03] 2.1	23.0 [6.74] 2.2	22.7 [6.65] 2.3	22.4 [6.56] 2.3
	45 [7.2]	Total BTUH [kW] Power	28.4 [8.32] 1.9	28.0 [8.21] 1.9	27.6 [8.09] 2.0	27.1 [7.94] 2.1	26.8 [7.85] 2.1	26.4 [7.74] 2.2	25.5 [7.47] 2.3	25.1 [7.36] 2.3	24.8 [7.27] 2.4
50 [10]	Total BTUH [kW] Power	31.0 [9.09] 1.9	30.5 [8.94] 2.0	30.1 [8.82] 2.0	29.7 [8.70] 2.1	29.3 [8.59] 2.2	28.9 [8.47] 2.2	28.0 [8.21] 2.3	27.6 [8.09] 2.4	27.2 [7.97] 2.4	

IDB—Indoor air dry bulb

[] Designates Metric Conversions



HEATING PERFORMANCE DATA—RQNM-A036

IDB		60°F [15.5°C]			70°F [21.1°C]			80°F [26.7°C]			
CFM [L/s]		1440 [680]	1200 [566]	960 [453]	1440 [680]	1200 [566]	960 [453]	1440 [680]	1200 [566]	960 [453]	
OUTDOOR DRY BULB TEMPERATURE °F [°C]	0 [-17.8]	Total BTUH [kW] Power	11.5 [3.37] 1.8	11.4 [3.34] 1.8	11.2 [3.28] 1.8	9.8 [2.87] 2.0	9.7 [2.84] 2.1	9.5 [2.78] 2.1	8.7 [2.55] 2.3	8.6 [2.52] 2.3	8.4 [2.46] 2.4
	5 [-15]	Total BTUH [kW] Power	14.0 [4.10] 1.8	13.9 [4.07] 1.9	13.7 [4.02] 1.9	12.3 [3.60] 2.1	12.2 [3.58] 2.1	12.0 [3.52] 2.2	11.2 [3.28] 2.3	11.1 [3.25] 2.4	10.9 [3.19] 2.4
	10 [-12.2]	Total BTUH [kW] Power	16.6 [4.86] 1.9	16.4 [4.81] 1.9	16.1 [4.72] 2.0	14.9 [4.37] 2.1	14.7 [4.31] 2.2	14.5 [4.25] 2.2	13.8 [4.04] 2.4	13.6 [3.99] 2.4	13.4 [3.93] 2.5
	15 [-9.4]	Total BTUH [kW] Power	19.2 [5.63] 1.9	18.9 [5.54] 2.0	18.6 [5.45] 2.0	17.4 [5.10] 2.2	17.2 [5.04] 2.2	17.0 [4.98] 2.3	16.3 [4.78] 2.4	16.1 [4.72] 2.5	15.9 [4.66] 2.5
	20 [-6.7]	Total BTUH [kW] Power	21.7 [6.36] 2.0	21.4 [6.27] 2.0	21.1 [6.18] 2.1	20.0 [5.86] 2.2	19.7 [5.77] 2.3	19.5 [5.71] 2.3	18.9 [5.54] 2.5	18.6 [5.45] 2.5	18.4 [5.39] 2.6
	25 [-3.9]	Total BTUH [kW] Power	24.3 [7.12] 2.0	24.0 [7.03] 2.1	23.6 [6.92] 2.1	22.6 [6.62] 2.3	22.3 [6.54] 2.3	22.0 [6.45] 2.4	21.5 [6.30] 2.5	21.2 [6.21] 2.6	20.9 [6.13] 2.7
	30 [-1.1]	Total BTUH [kW] Power	26.9 [7.88] 2.1	26.5 [7.77] 2.1	26.2 [7.68] 2.2	25.2 [7.39] 2.3	24.9 [7.30] 2.4	24.5 [7.18] 2.4	24.1 [7.06] 2.6	23.8 [6.98] 2.6	23.4 [6.86] 2.7
	35 [1.7]	Total BTUH [kW] Power	29.5 [8.65] 2.1	29.1 [8.53] 2.2	28.7 [8.41] 2.2	27.8 [8.15] 2.4	27.4 [8.03] 2.4	27.0 [7.91] 2.5	26.7 [7.83] 2.6	26.3 [7.71] 2.7	26.0 [7.62] 2.8
	40 [4.4]	Total BTUH [kW] Power	32.2 [9.44] 2.2	31.7 [9.29] 2.2	31.3 [9.17] 2.3	30.4 [8.91] 2.4	30.0 [8.79] 2.5	29.6 [8.67] 2.5	29.3 [8.59] 2.7	28.9 [8.47] 2.7	28.5 [8.35] 2.8
	45 [7.2]	Total BTUH [kW] Power	34.8 [10.20] 2.2	34.3 [10.05] 2.3	33.8 [9.91] 2.3	33.1 [9.70] 2.5	32.6 [9.55] 2.5	32.2 [9.44] 2.6	32.0 [9.38] 2.7	31.5 [9.23] 2.8	31.1 [9.11] 2.9
50 [10]	Total BTUH [kW] Power	37.5 [10.99] 2.3	36.9 [10.81] 2.3	36.4 [10.67] 2.4	35.7 [10.46] 2.5	35.2 [10.32] 2.6	34.7 [10.17] 2.6	34.6 [10.14] 2.8	34.1 [9.99] 2.8	33.7 [9.88] 2.9	

IDB—Indoor air dry bulb

HEATING PERFORMANCE DATA—RQNM-A042

IDB		60°F [15.5°C]			70°F [21.1°C]			80°F [26.7°C]			
CFM [L/s]		1740 [821]	1450 [684]	1160 [547]	1740 [821]	1450 [684]	1160 [547]	1740 [821]	1450 [684]	1160 [547]	
OUTDOOR DRY BULB TEMPERATURE °F [°C]	0 [-17.8]	Total BTUH [kW] Power	12.4 [3.63] 2.2	12.2 [3.58] 2.3	12.0 [3.52] 2.3	11.1 [3.25] 2.5	11.0 [3.22] 2.6	10.8 [3.17] 2.6	9.9 [2.90] 2.8	9.7 [2.84] 2.9	9.6 [2.81] 3.0
	5 [-15]	Total BTUH [kW] Power	15.4 [4.51] 2.3	15.2 [4.45] 2.3	14.9 [4.37] 2.4	14.1 [4.13] 2.6	13.9 [4.07] 2.6	13.7 [4.02] 2.7	12.9 [3.78] 2.9	12.7 [3.72] 3.0	12.5 [3.66] 3.0
	10 [-12.2]	Total BTUH [kW] Power	18.5 [5.42] 2.3	18.3 [5.36] 2.4	18.0 [5.28] 2.4	17.3 [5.07] 2.6	17.0 [4.98] 2.7	16.8 [4.92] 2.7	16.0 [4.69] 3.0	15.8 [4.63] 3.0	15.6 [4.57] 3.1
	15 [-9.4]	Total BTUH [kW] Power	21.7 [6.36] 2.4	21.4 [6.27] 2.4	21.1 [6.18] 2.5	20.5 [6.01] 2.7	20.2 [5.92] 2.7	19.9 [5.83] 2.8	19.2 [5.63] 3.0	19.0 [5.57] 3.1	18.7 [5.48] 3.2
	20 [-6.7]	Total BTUH [kW] Power	25.0 [7.33] 2.4	24.6 [7.21] 2.5	24.3 [7.12] 2.6	23.7 [6.95] 2.7	23.4 [6.86] 2.8	23.0 [6.74] 2.9	22.5 [6.59] 3.1	22.2 [6.51] 3.1	21.8 [6.39] 3.2
	25 [-3.9]	Total BTUH [kW] Power	28.2 [8.26] 2.5	27.8 [8.15] 2.5	27.4 [8.03] 2.6	26.9 [7.88] 2.8	26.5 [7.77] 2.8	26.1 [7.65] 2.9	25.6 [7.50] 3.1	25.3 [7.41] 3.2	24.9 [7.30] 3.3
	30 [-1.1]	Total BTUH [kW] Power	31.2 [9.14] 2.5	30.8 [9.03] 2.6	30.3 [8.88] 2.7	29.9 [8.76] 2.8	29.5 [8.65] 2.9	29.1 [8.53] 3.0	28.7 [8.41] 3.2	28.3 [8.29] 3.2	27.9 [8.18] 3.3
	35 [1.7]	Total BTUH [kW] Power	34.1 [9.99] 2.6	33.6 [9.85] 2.7	33.1 [9.70] 2.7	32.8 [9.61] 2.9	32.3 [9.47] 2.9	31.9 [9.35] 3.0	31.6 [9.26] 3.2	31.1 [9.11] 3.3	30.7 [9.00] 3.4
	40 [4.4]	Total BTUH [kW] Power	36.6 [10.73] 2.6	36.1 [10.58] 2.7	35.6 [10.43] 2.8	35.4 [10.37] 2.9	34.9 [10.23] 3.0	34.4 [10.08] 3.1	34.1 [9.99] 3.3	33.7 [9.88] 3.3	33.2 [9.73] 3.4
	45 [7.2]	Total BTUH [kW] Power	38.9 [11.40] 2.7	38.4 [11.25] 2.8	37.8 [11.08] 2.8	37.6 [11.02] 3.0	37.1 [10.87] 3.1	36.6 [10.73] 3.1	36.4 [10.67] 3.3	35.9 [10.52] 3.4	35.4 [10.37] 3.5
50 [10]	Total BTUH [kW] Power	40.8 [11.96] 2.7	40.2 [11.78] 2.8	39.6 [11.61] 2.9	39.5 [11.58] 3.0	38.9 [11.40] 3.1	38.4 [11.25] 3.2	38.3 [11.22] 3.4	37.7 [11.05] 3.5	37.2 [10.90] 3.5	

IDB—Indoor air dry bulb

[] Designates Metric Conversions



HEATING PERFORMANCE DATA—RQNM-A048

IDB		60°F [15.5°C]			70°F [21.1°C]			80°F [26.7°C]			
CFM [L/s]		1860 [878]	1500 [732]	1240 [585]	1860 [878]	1500 [732]	1240 [585]	1860 [878]	1500 [732]	1240 [585]	
OUTDOOR DRY BULB TEMPERATURE °F [°C]	0 [-17.8]	Total BTUH [kW] Power	13.3 [3.90] 2.3	13.1 [3.84] 2.4	12.9 [3.78] 2.4	11.7 [3.43] 2.7	11.5 [3.37] 2.7	11.4 [3.34] 2.8	10.4 [3.05] 3.0	10.3 [3.02] 3.1	10.1 [2.96] 3.2
	5 [-15]	Total BTUH [kW] Power	17.4 [5.10] 2.4	17.1 [5.01] 2.4	16.9 [4.95] 2.5	15.7 [4.60] 2.7	15.5 [4.54] 2.8	15.3 [4.48] 2.9	14.5 [4.25] 3.1	14.3 [4.19] 3.2	14.1 [4.13] 3.2
	10 [-12.2]	Total BTUH [kW] Power	21.3 [6.24] 2.4	21.0 [6.15] 2.5	20.7 [6.07] 2.6	19.7 [5.77] 2.8	19.4 [5.69] 2.9	19.1 [5.60] 2.9	18.4 [5.39] 3.1	18.2 [5.33] 3.2	17.9 [5.25] 3.3
	15 [-9.4]	Total BTUH [kW] Power	25.1 [7.36] 2.5	24.7 [7.24] 2.6	24.4 [7.15] 2.6	23.5 [6.89] 2.9	23.1 [6.77] 2.9	22.8 [6.68] 3.0	22.2 [6.51] 3.2	21.9 [6.42] 3.3	21.6 [6.33] 3.4
	20 [-6.7]	Total BTUH [kW] Power	28.7 [8.41] 2.6	28.3 [8.29] 2.6	27.9 [8.18] 2.7	27.1 [7.94] 2.9	26.7 [7.83] 3.0	26.4 [7.74] 3.1	25.9 [7.59] 3.3	25.5 [7.47] 3.4	25.1 [7.36] 3.4
	25 [-3.9]	Total BTUH [kW] Power	32.3 [9.47] 2.6	31.8 [9.32] 2.7	31.4 [9.20] 2.8	30.7 [9.00] 3.0	30.2 [8.85] 3.1	29.8 [8.73] 3.1	29.4 [8.62] 3.3	29.0 [8.50] 3.4	28.6 [8.38] 3.5
	30 [-1.1]	Total BTUH [kW] Power	35.7 [10.46] 2.7	35.2 [10.32] 2.8	34.7 [10.17] 2.8	34.1 [9.99] 3.0	33.6 [9.85] 3.1	33.1 [9.70] 3.2	32.8 [9.61] 3.4	32.4 [9.50] 3.5	31.9 [9.35] 3.6
	35 [1.7]	Total BTUH [kW] Power	39.0 [11.43] 2.8	38.4 [11.25] 2.8	37.9 [11.11] 2.9	37.4 [10.96] 3.1	36.8 [10.79] 3.2	36.3 [10.64] 3.3	36.1 [10.58] 3.5	35.6 [10.43] 3.6	35.1 [10.29] 3.6
	40 [4.4]	Total BTUH [kW] Power	42.1 [12.34] 2.8	41.5 [12.16] 2.9	40.9 [11.99] 3.0	40.5 [11.87] 3.2	39.9 [11.69] 3.3	39.4 [11.55] 3.3	39.2 [11.49] 3.5	38.7 [11.34] 3.6	38.1 [11.17] 3.7
	45 [7.2]	Total BTUH [kW] Power	45.1 [13.22] 2.9	44.5 [13.04] 3.0	43.9 [12.87] 3.0	43.5 [12.75] 3.2	42.9 [12.57] 3.3	42.3 [12.40] 3.4	42.3 [12.40] 3.6	41.7 [12.22] 3.7	41.1 [12.05] 3.8
50 [10]	Total BTUH [kW] Power	48.0 [14.07] 2.9	47.4 [13.89] 3.0	46.7 [13.69] 3.1	46.4 [13.60] 3.3	45.8 [13.42] 3.4	45.1 [13.22] 3.5	45.2 [13.25] 3.7	44.5 [13.04] 3.7	43.9 [12.87] 3.8	

IDB—Indoor air dry bulb

HEATING PERFORMANCE DATA—RQNM-A060

IDB		60°F [15.5°C]			70°F [21.1°C]			80°F [26.7°C]			
CFM [L/s]		2280 [1076]	1900 [897]	1520 [717]	2280 [1076]	1900 [897]	1520 [717]	2280 [1076]	1900 [897]	1520 [717]	
OUTDOOR DRY BULB TEMPERATURE °F [°C]	0 [-17.8]	Total BTUH [kW] Power	24.6 [7.21] 2.9	24.2 [7.09] 3.0	23.9 [7.00] 3.1	23.6 [6.92] 3.4	23.3 [6.83] 3.5	23.0 [6.74] 3.6	21.7 [6.36] 3.9	21.4 [6.27] 4.0	21.1 [6.18] 4.1
	5 [-15]	Total BTUH [kW] Power	27.8 [8.15] 3.0	27.4 [8.03] 3.1	27.1 [7.94] 3.2	26.9 [7.88] 3.5	26.5 [7.77] 3.6	26.2 [7.68] 3.7	25.0 [7.33] 4.0	24.7 [7.24] 4.1	24.3 [7.12] 4.2
	10 [-12.2]	Total BTUH [kW] Power	31.2 [9.14] 3.1	30.8 [9.03] 3.2	30.4 [8.91] 3.3	30.3 [8.88] 3.6	29.9 [8.76] 3.7	29.5 [8.65] 3.8	28.4 [8.32] 4.1	28.0 [8.21] 4.2	27.6 [8.09] 4.3
	15 [-9.4]	Total BTUH [kW] Power	34.7 [10.17] 3.2	34.2 [10.02] 3.3	33.8 [9.91] 3.3	33.8 [9.91] 3.7	33.3 [9.76] 3.8	32.9 [9.64] 3.9	31.9 [9.35] 4.2	31.4 [9.20] 4.3	31.0 [9.09] 4.4
	20 [-6.7]	Total BTUH [kW] Power	38.4 [11.25] 3.3	37.8 [11.08] 3.4	37.3 [10.93] 3.4	37.4 [10.96] 3.7	36.9 [10.81] 3.8	36.4 [10.67] 3.9	35.5 [10.40] 4.3	35.0 [10.26] 4.4	34.5 [10.11] 4.5
	25 [-3.9]	Total BTUH [kW] Power	42.1 [12.34] 3.3	41.5 [12.16] 3.4	40.9 [11.99] 3.5	41.2 [12.07] 3.8	40.6 [11.90] 3.9	40.0 [11.72] 4.0	39.2 [11.49] 4.3	38.7 [11.34] 4.4	38.1 [11.17] 4.6
	30 [-1.1]	Total BTUH [kW] Power	45.9 [13.45] 3.4	45.3 [13.28] 3.5	44.6 [13.07] 3.6	45.0 [13.19] 3.9	44.4 [13.01] 4.0	43.7 [12.81] 4.1	43.1 [12.63] 4.4	42.5 [12.46] 4.5	41.9 [12.28] 4.6
	35 [1.7]	Total BTUH [kW] Power	49.9 [14.62] 3.5	49.2 [14.42] 3.6	48.5 [14.21] 3.7	49.0 [14.36] 4.0	48.3 [14.16] 4.1	47.6 [13.95] 4.2	47.1 [13.80] 4.5	46.4 [13.60] 4.6	45.7 [13.39] 4.7
	40 [4.4]	Total BTUH [kW] Power	54.0 [15.83] 3.6	53.2 [15.59] 3.7	52.5 [15.39] 3.8	53.1 [15.56] 4.1	52.3 [15.33] 4.2	51.6 [15.12] 4.3	51.1 [14.98] 4.6	50.4 [14.77] 4.7	49.7 [14.57] 4.8
	45 [7.2]	Total BTUH [kW] Power	58.2 [17.06] 3.7	57.3 [16.79] 3.8	56.5 [16.56] 3.9	57.2 [16.76] 4.1	56.4 [16.53] 4.3	55.6 [16.29] 4.4	55.3 [16.21] 4.7	54.5 [15.97] 4.8	53.8 [15.77] 4.9
50 [10]	Total BTUH [kW] Power	62.5 [18.32] 3.7	61.6 [18.05] 3.8	60.7 [17.79] 3.9	61.6 [18.05] 4.2	60.7 [17.79] 4.3	59.8 [17.53] 4.4	59.6 [17.47] 4.7	58.8 [17.23] 4.9	58.0 [17.00] 5.0	

IDB—Indoor air dry bulb

[] Designates Metric Conversions



HEATING PERFORMANCE DATA—RQPM-A024

IDB		60°F [15.5°C]			70°F [21.1°C]			80°F [26.7°C]			
CFM [L/s]		960 [453]	800 [378]	640 [302]	960 [453]	800 [378]	640 [302]	960 [453]	800 [378]	640 [302]	
OUTDOOR DRY BULB TEMPERATURE °F [°C]	0 [-17.8]	Total BTUH [kW] Power	8.8 [2.58] 1.4	8.6 [2.52] 1.4	8.5 [2.49] 1.4	7.5 [2.20] 1.5	7.4 [2.17] 1.5	7.3 [2.14] 1.6	6.8 [1.99] 1.8	6.7 [1.96] 1.8	6.6 [1.93] 1.8
	5 [-15]	Total BTUH [kW] Power	10.5 [3.08] 1.4	10.4 [3.05] 1.4	10.2 [2.99] 1.5	9.3 [2.73] 1.5	9.2 [2.70] 1.6	9.0 [2.64] 1.6	8.6 [2.52] 1.8	8.5 [2.49] 1.8	8.4 [2.46] 1.9
	10 [-12.2]	Total BTUH [kW] Power	12.2 [3.58] 1.4	12.1 [3.55] 1.5	11.9 [3.49] 1.5	11.0 [3.22] 1.6	10.8 [3.17] 1.6	10.7 [3.14] 1.6	10.3 [3.02] 1.8	10.2 [2.99] 1.9	10.0 [2.93] 1.9
	15 [-9.4]	Total BTUH [kW] Power	13.8 [4.04] 1.5	13.6 [3.99] 1.5	13.4 [3.93] 1.5	12.6 [3.69] 1.6	12.4 [3.63] 1.6	12.2 [3.58] 1.7	11.9 [3.49] 1.8	11.7 [3.43] 1.9	11.6 [3.40] 1.9
	20 [-6.7]	Total BTUH [kW] Power	15.4 [4.51] 1.5	15.2 [4.45] 1.5	15.0 [4.40] 1.6	14.2 [4.16] 1.6	14.0 [4.10] 1.7	13.8 [4.04] 1.7	13.5 [3.96] 1.9	13.3 [3.90] 1.9	13.1 [3.84] 2.0
	25 [-3.9]	Total BTUH [kW] Power	16.9 [4.95] 1.5	16.7 [4.89] 1.6	16.5 [4.84] 1.6	15.7 [4.60] 1.6	15.5 [4.54] 1.7	15.3 [4.48] 1.7	15.0 [4.40] 1.9	14.8 [4.34] 1.9	14.6 [4.28] 2.0
	30 [-1.1]	Total BTUH [kW] Power	18.5 [5.42] 1.5	18.2 [5.33] 1.6	18.0 [5.28] 1.6	17.3 [5.07] 1.7	17.0 [4.98] 1.7	16.8 [4.92] 1.8	16.6 [4.86] 1.9	16.4 [4.81] 2.0	16.1 [4.72] 2.0
	35 [1.7]	Total BTUH [kW] Power	20.1 [5.89] 1.6	19.8 [5.80] 1.6	19.6 [5.74] 1.7	18.9 [5.54] 1.7	18.6 [5.45] 1.7	18.4 [5.39] 1.8	18.2 [5.33] 2.0	17.9 [5.25] 2.0	17.7 [5.19] 2.1
	40 [4.4]	Total BTUH [kW] Power	21.8 [6.39] 1.6	21.5 [6.30] 1.6	21.2 [6.21] 1.7	20.6 [6.04] 1.7	20.3 [5.95] 1.8	20.0 [5.86] 1.8	19.9 [5.83] 2.0	19.6 [5.74] 2.0	19.3 [5.66] 2.1
	45 [7.2]	Total BTUH [kW] Power	23.6 [6.92] 1.6	23.3 [6.83] 1.7	23.0 [6.74] 1.7	22.4 [6.56] 1.8	22.1 [6.48] 1.8	21.8 [6.39] 1.8	21.7 [6.36] 2.0	21.4 [6.27] 2.1	21.1 [6.18] 2.1
50 [10]	Total BTUH [kW] Power	25.6 [7.50] 1.7	25.2 [7.39] 1.7	24.9 [7.30] 1.7	24.4 [7.15] 1.8	24.0 [7.03] 1.8	23.7 [6.95] 1.9	23.7 [6.95] 2.0	23.4 [6.86] 2.1	23.0 [6.74] 2.1	

IDB—Indoor air dry bulb

HEATING PERFORMANCE DATA—RQPM-A030

IDB		60°F [15.5°C]			70°F [21.1°C]			80°F [26.7°C]			
CFM [L/s]		1200 [566]	1000 [472]	800 [378]	1200 [566]	1000 [472]	800 [378]	1200 [566]	1000 [472]	800 [378]	
OUTDOOR DRY BULB TEMPERATURE °F [°C]	0 [-17.8]	Total BTUH [kW] Power	10.3 [3.02] 1.6	10.1 [2.96] 1.6	10.0 [2.93] 1.7	8.9 [2.61] 1.7	8.8 [2.58] 1.8	8.7 [2.55] 1.8	7.5 [2.20] 2.0	7.4 [2.17] 2.0	7.3 [2.14] 2.1
	5 [-15]	Total BTUH [kW] Power	12.0 [3.52] 1.6	11.8 [3.46] 1.7	11.6 [3.40] 1.7	10.6 [3.11] 1.8	10.5 [3.08] 1.8	10.3 [3.02] 1.9	9.2 [2.70] 2.0	9.1 [2.67] 2.1	9.0 [2.64] 2.1
	10 [-12.2]	Total BTUH [kW] Power	13.8 [4.04] 1.6	13.6 [3.99] 1.7	13.4 [3.93] 1.7	12.4 [3.63] 1.8	12.2 [3.58] 1.9	12.0 [3.52] 1.9	11.0 [3.22] 2.1	10.9 [3.19] 2.1	10.7 [3.14] 2.2
	15 [-9.4]	Total BTUH [kW] Power	15.6 [4.57] 1.7	15.4 [4.51] 1.7	15.2 [4.45] 1.8	14.2 [4.16] 1.9	14.0 [4.10] 1.9	13.8 [4.04] 1.9	12.9 [3.78] 2.1	12.7 [3.72] 2.1	12.5 [3.66] 2.2
	20 [-6.7]	Total BTUH [kW] Power	17.6 [5.16] 1.7	17.3 [5.07] 1.8	17.1 [5.01] 1.8	16.2 [4.75] 1.9	16.0 [4.69] 1.9	15.7 [4.60] 2.0	14.8 [4.34] 2.1	14.6 [4.28] 2.2	14.4 [4.22] 2.2
	25 [-3.9]	Total BTUH [kW] Power	19.6 [5.74] 1.7	19.3 [5.66] 1.8	19.0 [5.57] 1.8	18.2 [5.33] 1.9	17.9 [5.25] 2.0	17.7 [5.19] 2.0	16.8 [4.92] 2.2	16.6 [4.86] 2.2	16.3 [4.78] 2.3
	30 [-1.1]	Total BTUH [kW] Power	21.6 [6.33] 1.8	21.3 [6.24] 1.8	21.0 [6.15] 1.9	20.3 [5.95] 2.0	20.0 [5.86] 2.0	19.7 [5.77] 2.1	18.9 [5.54] 2.2	18.6 [5.45] 2.2	18.4 [5.39] 2.3
	35 [1.7]	Total BTUH [kW] Power	23.8 [6.98] 1.8	23.5 [6.89] 1.9	23.1 [6.77] 1.9	22.4 [6.56] 2.0	22.1 [6.48] 2.0	21.8 [6.39] 2.1	21.1 [6.18] 2.2	20.8 [6.10] 2.3	20.5 [6.01] 2.3
	40 [4.4]	Total BTUH [kW] Power	26.0 [7.62] 1.9	25.7 [7.53] 1.9	25.3 [7.41] 1.9	24.7 [7.24] 2.0	24.3 [7.12] 2.1	24.0 [7.03] 2.1	23.3 [6.83] 2.3	23.0 [6.74] 2.3	22.6 [6.62] 2.4
	45 [7.2]	Total BTUH [kW] Power	28.4 [8.32] 1.9	28.0 [8.21] 1.9	27.6 [8.09] 2.0	27.0 [7.91] 2.1	26.6 [7.80] 2.1	26.2 [7.68] 2.2	25.6 [7.50] 2.3	25.2 [7.39] 2.4	24.9 [7.30] 2.4
50 [10]	Total BTUH [kW] Power	30.8 [9.03] 1.9	30.3 [8.88] 2.0	29.9 [8.76] 2.0	29.4 [8.62] 2.1	29.0 [8.50] 2.1	28.6 [8.38] 2.2	28.0 [8.21] 2.3	27.6 [8.09] 2.4	27.2 [7.97] 2.5	

IDB—Indoor air dry bulb

[] Designates Metric Conversions



HEATING PERFORMANCE DATA—RQPM-A036

IDB		60°F [15.5°C]			70°F [21.1°C]			80°F [26.7°C]			
CFM [L/s]		1440 [680]	1200 [566]	960 [453]	1440 [680]	1200 [566]	960 [453]	1440 [680]	1200 [566]	960 [453]	
OUTDOOR DRY BULB TEMPERATURE °F [°C]	0 [-17.8]	Total BTUH [kW] Power	11.3 [3.31] 1.7	11.1 [3.25] 1.8	11.0 [3.22] 1.8	9.8 [2.87] 2.0	9.7 [2.84] 2.1	9.5 [2.78] 2.1	8.8 [2.58] 2.3	8.7 [2.55] 2.3	8.6 [2.52] 2.4
	5 [-15]	Total BTUH [kW] Power	13.9 [4.07] 1.8	13.7 [4.02] 1.8	13.5 [3.96] 1.9	12.4 [3.63] 2.1	12.2 [3.58] 2.1	12.1 [3.55] 2.2	11.5 [3.37] 2.3	11.3 [3.31] 2.4	11.1 [3.25] 2.4
	10 [-12.2]	Total BTUH [kW] Power	16.5 [4.84] 1.8	16.3 [4.78] 1.9	16.0 [4.69] 1.9	15.0 [4.40] 2.1	14.8 [4.34] 2.2	14.6 [4.28] 2.2	14.1 [4.13] 2.4	13.9 [4.07] 2.4	13.7 [4.02] 2.5
	15 [-9.4]	Total BTUH [kW] Power	19.1 [5.60] 1.9	18.8 [5.51] 1.9	18.6 [5.45] 2.0	17.6 [5.16] 2.2	17.4 [5.10] 2.2	17.1 [5.01] 2.3	16.7 [4.89] 2.4	16.4 [4.81] 2.5	16.2 [4.75] 2.6
	20 [-6.7]	Total BTUH [kW] Power	21.7 [6.36] 1.9	21.4 [6.27] 2.0	21.1 [6.18] 2.0	20.2 [5.92] 2.2	19.9 [5.83] 2.3	19.6 [5.74] 2.4	19.2 [5.63] 2.5	19.0 [5.57] 2.6	18.7 [5.48] 2.6
	25 [-3.9]	Total BTUH [kW] Power	24.3 [7.12] 2.0	23.9 [7.00] 2.1	23.6 [6.92] 2.1	22.8 [6.68] 2.3	22.5 [6.59] 2.4	22.2 [6.51] 2.4	21.8 [6.39] 2.5	21.5 [6.30] 2.6	21.2 [6.21] 2.7
	30 [-1.1]	Total BTUH [kW] Power	26.8 [7.85] 2.1	26.5 [7.77] 2.1	26.1 [7.65] 2.2	25.4 [7.44] 2.3	25.0 [7.33] 2.4	24.7 [7.24] 2.5	24.4 [7.15] 2.6	24.1 [7.06] 2.7	23.7 [6.95] 2.7
	35 [1.7]	Total BTUH [kW] Power	29.4 [8.62] 2.1	29.0 [8.50] 2.2	28.6 [8.38] 2.2	27.9 [8.18] 2.4	27.5 [8.06] 2.5	27.2 [7.97] 2.5	27.0 [7.91] 2.7	26.6 [7.80] 2.7	26.2 [7.68] 2.8
	40 [4.4]	Total BTUH [kW] Power	32.0 [9.38] 2.2	31.5 [9.23] 2.2	31.1 [9.11] 2.3	30.5 [8.94] 2.5	30.1 [8.82] 2.5	29.6 [8.67] 2.6	29.5 [8.65] 2.7	29.1 [8.53] 2.8	28.7 [8.41] 2.8
	45 [7.2]	Total BTUH [kW] Power	34.5 [10.11] 2.2	34.1 [9.99] 2.3	33.6 [9.85] 2.3	33.1 [9.70] 2.5	32.6 [9.55] 2.6	32.1 [9.41] 2.6	32.1 [9.41] 2.8	31.6 [9.26] 2.8	31.2 [9.14] 2.9
50 [10]	Total BTUH [kW] Power	37.1 [10.87] 2.3	36.6 [10.73] 2.3	36.0 [10.55] 2.4	35.6 [10.43] 2.6	35.1 [10.29] 2.6	34.6 [10.14] 2.7	34.7 [10.17] 2.8	34.2 [10.02] 2.9	33.7 [9.88] 3.0	

IDB—Indoor air dry bulb

HEATING PERFORMANCE DATA—RQPM-A037

IDB		60°F [15.5°C]			70°F [21.1°C]			80°F [26.7°C]			
CFM [L/s]		1440 [680]	1200 [566]	960 [453]	1440 [680]	1200 [566]	960 [453]	1440 [680]	1200 [566]	960 [453]	
OUTDOOR DRY BULB TEMPERATURE °F [°C]	0 [-17.8]	Total BTUH [kW] Power	11.9 [3.5] 1.9	11.7 [3.4] 1.9	11.5 [3.4] 2.0	10.6 [3.1] 2.1	10.5 [3.1] 2.2	10.3 [3.0] 2.2	9.3 [2.7] 2.4	9.2 [2.7] 2.4	9.1 [2.7] 2.5
	5 [-15]	Total BTUH [kW] Power	14.4 [4.2] 1.9	14.2 [4.2] 2.0	13.9 [4.1] 2.0	13.1 [3.8] 2.1	12.9 [3.8] 2.2	12.7 [3.7] 2.3	11.8 [3.5] 2.4	11.7 [3.4] 2.5	11.5 [3.4] 2.5
	10 [-12.2]	Total BTUH [kW] Power	16.8 [4.9] 1.9	16.6 [4.9] 2.0	16.4 [4.8] 2.0	15.6 [4.6] 2.2	15.4 [4.5] 2.2	15.1 [4.4] 2.3	14.3 [4.2] 2.5	14.1 [4.1] 2.5	13.9 [4.1] 2.6
	15 [-9.4]	Total BTUH [kW] Power	19.3 [5.7] 2.0	19.1 [5.6] 2.0	18.8 [5.5] 2.1	18.1 [5.3] 2.2	17.8 [5.2] 2.3	17.6 [5.2] 2.4	16.8 [4.9] 2.5	16.6 [4.9] 2.6	16.3 [4.8] 2.6
	20 [-6.7]	Total BTUH [kW] Power	21.8 [6.4] 2.0	21.5 [6.3] 2.1	21.2 [6.2] 2.1	20.6 [6.0] 2.3	20.3 [5.9] 2.3	20.0 [5.9] 2.4	19.3 [5.7] 2.5	19.0 [5.6] 2.6	18.8 [5.5] 2.7
	25 [-3.9]	Total BTUH [kW] Power	24.3 [7.1] 2.1	24.0 [7.0] 2.1	23.6 [6.9] 2.2	23.0 [6.7] 2.3	22.7 [6.7] 2.4	22.4 [6.6] 2.4	21.8 [6.4] 2.6	21.5 [6.3] 2.7	21.2 [6.2] 2.7
	30 [-1.1]	Total BTUH [kW] Power	26.8 [7.9] 2.1	26.4 [7.7] 2.2	26.0 [7.6] 2.2	25.5 [7.5] 2.4	25.2 [7.4] 2.4	24.8 [7.3] 2.5	24.3 [7.1] 2.6	23.9 [7.0] 2.7	23.6 [6.9] 2.8
	35 [1.7]	Total BTUH [kW] Power	29.3 [8.6] 2.2	28.9 [8.5] 2.2	28.5 [8.4] 2.3	28.0 [8.2] 2.4	27.6 [8.1] 2.5	27.2 [8.0] 2.5	26.8 [7.9] 2.7	26.4 [7.7] 2.7	26.0 [7.6] 2.8
	40 [4.4]	Total BTUH [kW] Power	31.8 [9.3] 2.2	31.3 [9.2] 2.3	30.9 [9.1] 2.3	30.5 [8.9] 2.5	30.1 [8.8] 2.5	29.7 [8.7] 2.6	29.3 [8.6] 2.7	28.8 [8.4] 2.8	28.4 [8.3] 2.9
	45 [7.2]	Total BTUH [kW] Power	34.3 [10.1] 2.3	33.8 [9.9] 2.3	33.3 [9.8] 2.4	33.0 [9.7] 2.5	32.5 [9.5] 2.6	32.1 [9.4] 2.6	31.7 [9.3] 2.8	31.3 [9.2] 2.8	30.8 [9.0] 2.9
50 [10]	Total BTUH [kW] Power	36.7 [10.8] 2.3	36.2 [10.6] 2.4	35.7 [10.5] 2.4	35.5 [10.4] 2.5	35.0 [10.3] 2.6	34.5 [10.1] 2.7	34.2 [10.0] 2.8	33.7 [9.9] 2.9	33.3 [9.8] 3.0	

IDB—Indoor air dry bulb

[] Designates Metric Conversions



HEATING PERFORMANCE DATA—RQPM-A042

IDB		60°F [15.5°C]			70°F [21.1°C]			80°F [26.7°C]			
CFM [L/s]		1740 [821]	1450 [684]	1160 [547]	1740 [821]	1450 [684]	1160 [547]	1740 [821]	1450 [684]	1160 [547]	
OUTDOOR DRY BULB TEMPERATURE °F [°C]	0 [-17.8]	Total BTUH [kW] Power	12.4 [3.63] 2.2	12.2 [3.58] 2.3	12.0 [3.52] 2.3	11.1 [3.25] 2.5	11.0 [3.22] 2.6	10.8 [3.17] 2.6	9.9 [2.90] 2.8	9.7 [2.84] 2.9	9.6 [2.81] 3.0
	5 [-15]	Total BTUH [kW] Power	15.4 [4.51] 2.3	15.2 [4.45] 2.3	14.9 [4.37] 2.4	14.1 [4.13] 2.6	13.9 [4.07] 2.6	13.7 [4.02] 2.7	12.9 [3.78] 2.9	12.7 [3.72] 3.0	12.5 [3.66] 3.0
	10 [-12.2]	Total BTUH [kW] Power	18.5 [5.42] 2.3	18.3 [5.36] 2.4	18.0 [5.28] 2.4	17.3 [5.07] 2.6	17.0 [4.98] 2.7	16.8 [4.92] 2.7	16.0 [4.69] 3.0	15.8 [4.63] 3.0	15.6 [4.57] 3.1
	15 [-9.4]	Total BTUH [kW] Power	21.7 [6.36] 2.4	21.4 [6.27] 2.4	21.1 [6.18] 2.5	20.5 [6.01] 2.7	20.2 [5.92] 2.7	19.9 [5.83] 2.8	19.2 [5.63] 3.0	19.0 [5.57] 3.1	18.7 [5.48] 3.2
	20 [-6.7]	Total BTUH [kW] Power	25.0 [7.33] 2.4	24.6 [7.21] 2.5	24.3 [7.12] 2.6	23.7 [6.95] 2.7	23.4 [6.86] 2.8	23.0 [6.74] 2.9	22.5 [6.59] 3.1	22.2 [6.51] 3.1	21.8 [6.39] 3.2
	25 [-3.9]	Total BTUH [kW] Power	28.2 [8.26] 2.5	27.8 [8.15] 2.5	27.4 [8.03] 2.6	26.9 [7.88] 2.8	26.5 [7.77] 2.8	26.1 [7.65] 2.9	25.6 [7.50] 3.1	25.3 [7.41] 3.2	24.9 [7.30] 3.3
	30 [-1.1]	Total BTUH [kW] Power	31.2 [9.14] 2.5	30.8 [9.03] 2.6	30.3 [8.88] 2.7	29.9 [8.76] 2.8	29.5 [8.65] 2.9	29.1 [8.53] 3.0	28.7 [8.41] 3.2	28.3 [8.29] 3.2	27.9 [8.18] 3.3
	35 [1.7]	Total BTUH [kW] Power	34.1 [9.99] 2.6	33.6 [9.85] 2.7	33.1 [9.70] 2.7	32.8 [9.61] 2.9	32.3 [9.47] 2.9	31.9 [9.35] 3.0	31.6 [9.26] 3.2	31.1 [9.11] 3.3	30.7 [9.00] 3.4
	40 [4.4]	Total BTUH [kW] Power	36.6 [10.73] 2.6	36.1 [10.58] 2.7	35.6 [10.43] 2.8	35.4 [10.37] 2.9	34.9 [10.23] 3.0	34.4 [10.08] 3.1	34.1 [9.99] 3.3	33.7 [9.88] 3.3	33.2 [9.73] 3.4
	45 [7.2]	Total BTUH [kW] Power	38.9 [11.40] 2.7	38.4 [11.25] 2.8	37.8 [11.08] 2.8	37.6 [11.02] 3.0	37.1 [10.87] 3.1	36.6 [10.73] 3.1	36.4 [10.67] 3.3	35.9 [10.52] 3.4	35.4 [10.37] 3.5
50 [10]	Total BTUH [kW] Power	40.8 [11.96] 2.7	40.2 [11.78] 2.8	39.6 [11.61] 2.9	39.5 [11.58] 3.0	38.9 [11.40] 3.1	38.4 [11.25] 3.2	38.3 [11.22] 3.4	37.7 [11.05] 3.5	37.2 [10.90] 3.5	

IDB—Indoor air dry bulb

HEATING PERFORMANCE DATA—RQPM-A048

IDB		60°F [15.5°C]			70°F [21.1°C]			80°F [26.7°C]			
CFM [L/s]		1860 [878]	1550 [732]	1240 [585]	1860 [878]	1550 [732]	1240 [585]	1860 [878]	1550 [732]	1240 [585]	
OUTDOOR DRY BULB TEMPERATURE °F [°C]	0 [-17.8]	Total BTUH [kW] Power	12.7 [3.72] 2.3	12.6 [3.69] 2.4	12.4 [3.63] 2.4	11.5 [3.37] 2.7	11.3 [3.31] 2.7	11.1 [3.25] 2.8	10.0 [2.93] 3.0	9.9 [2.90] 3.1	9.7 [2.84] 3.2
	5 [-15]	Total BTUH [kW] Power	16.8 [4.92] 2.4	16.6 [4.86] 2.4	16.3 [4.78] 2.5	15.5 [4.54] 2.7	15.3 [4.48] 2.8	15.1 [4.43] 2.9	14.1 [4.13] 3.1	13.9 [4.07] 3.2	13.7 [4.02] 3.2
	10 [-12.2]	Total BTUH [kW] Power	20.7 [6.07] 2.4	20.4 [5.98] 2.5	20.1 [5.89] 2.6	19.5 [5.71] 2.8	19.2 [5.63] 2.8	18.9 [5.54] 2.9	18.0 [5.28] 3.1	17.8 [5.22] 3.2	17.5 [5.13] 3.3
	15 [-9.4]	Total BTUH [kW] Power	24.5 [7.18] 2.5	24.2 [7.09] 2.6	23.8 [6.98] 2.6	23.3 [6.83] 2.8	22.9 [6.71] 2.9	22.6 [6.62] 3.0	21.8 [6.39] 3.2	21.5 [6.30] 3.3	21.2 [6.21] 3.4
	20 [-6.7]	Total BTUH [kW] Power	28.2 [8.26] 2.6	27.8 [8.15] 2.6	27.4 [8.03] 2.7	26.9 [7.88] 2.9	26.6 [7.80] 3.0	26.2 [7.68] 3.0	25.5 [7.47] 3.3	25.2 [7.39] 3.4	24.8 [7.27] 3.4
	25 [-3.9]	Total BTUH [kW] Power	31.8 [9.32] 2.6	31.3 [9.17] 2.7	30.9 [9.06] 2.8	30.5 [8.94] 3.0	30.1 [8.82] 3.0	29.7 [8.70] 3.1	29.1 [8.53] 3.3	28.7 [8.41] 3.4	28.3 [8.29] 3.5
	30 [-1.1]	Total BTUH [kW] Power	35.2 [10.32] 2.7	34.7 [10.17] 2.8	34.2 [10.02] 2.8	34.0 [9.96] 3.0	33.5 [9.82] 3.1	33.0 [9.67] 3.2	32.5 [9.52] 3.4	32.1 [9.41] 3.5	31.6 [9.26] 3.6
	35 [1.7]	Total BTUH [kW] Power	38.5 [11.28] 2.8	38.0 [11.14] 2.8	37.5 [10.99] 2.9	37.3 [10.93] 3.1	36.7 [10.76] 3.2	36.2 [10.61] 3.2	35.8 [10.49] 3.4	35.3 [10.35] 3.5	34.8 [10.20] 3.6
	40 [4.4]	Total BTUH [kW] Power	41.7 [12.22] 2.8	41.1 [12.05] 2.9	40.6 [11.90] 3.0	40.5 [11.87] 3.1	39.9 [11.69] 3.2	39.3 [11.52] 3.3	39.0 [11.43] 3.5	38.5 [11.28] 3.6	37.9 [11.11] 3.7
	45 [7.2]	Total BTUH [kW] Power	44.8 [13.13] 2.9	44.2 [12.95] 2.9	43.5 [12.75] 3.0	43.5 [12.75] 3.2	42.9 [12.57] 3.3	42.3 [12.40] 3.4	42.1 [12.34] 3.6	41.5 [12.16] 3.7	40.9 [11.99] 3.8
50 [10]	Total BTUH [kW] Power	47.7 [13.98] 2.9	47.1 [13.80] 3.0	46.4 [13.60] 3.1	46.5 [13.63] 3.3	45.8 [13.42] 3.3	45.2 [13.25] 3.4	45.0 [13.19] 3.6	44.4 [13.01] 3.7	43.8 [12.84] 3.8	

IDB—Indoor air dry bulb

[] Designates Metric Conversions



HEATING PERFORMANCE DATA—RQPM-A049CK

IDB		60°F [15.5°C]			70°F [21.1°C]			80°F [26.7°C]			
CFM [L/s]		1860 [878]	1550 [732]	1240 [585]	1860 [878]	1550 [732]	1240 [585]	1860 [878]	1550 [732]	1240 [585]	
OUTDOOR DRY BULB TEMPERATURE °F [°C]	0 [-17.8]	Total BTUH [kW] Power	11.9 [3.49] 2.3	11.7 [3.43] 2.4	11.5 [3.37] 2.4	10.5 [3.08] 2.7	10.4 [3.05] 2.7	10.2 [2.99] 2.8	9.1 [2.67] 3.0	9.0 [2.64] 3.1	8.9 [2.61] 3.2
	5 [-15]	Total BTUH [kW] Power	15.2 [4.45] 2.4	15.0 [4.40] 2.4	14.7 [4.31] 2.5	13.8 [4.04] 2.7	13.6 [3.99] 2.8	13.4 [3.93] 2.9	12.5 [3.66] 3.1	12.3 [3.60] 3.2	12.1 [3.55] 3.2
	10 [-12.2]	Total BTUH [kW] Power	18.5 [5.42] 2.4	18.2 [5.33] 2.5	18.0 [5.28] 2.6	17.1 [5.01] 2.8	16.9 [4.95] 2.8	16.6 [4.86] 2.9	15.8 [4.63] 3.1	15.5 [4.54] 3.2	15.3 [4.48] 3.3
	15 [-9.4]	Total BTUH [kW] Power	21.8 [6.39] 2.5	21.5 [6.30] 2.6	21.2 [6.21] 2.6	20.4 [5.98] 2.8	20.1 [5.89] 2.9	19.9 [5.83] 3.0	19.1 [5.60] 3.2	18.8 [5.51] 3.3	18.5 [5.42] 3.4
	20 [-6.7]	Total BTUH [kW] Power	25.1 [7.36] 2.6	24.7 [7.24] 2.6	24.4 [7.15] 2.7	23.7 [6.95] 2.9	23.4 [6.86] 3.0	23.1 [6.77] 3.0	22.4 [6.56] 3.3	22.1 [6.48] 3.4	21.8 [6.39] 3.4
	25 [-3.9]	Total BTUH [kW] Power	28.4 [8.32] 2.6	28.0 [8.21] 2.7	27.6 [8.09] 2.8	27.1 [7.94] 3.0	26.7 [7.82] 3.0	26.3 [7.71] 3.1	25.7 [7.53] 3.3	25.3 [7.41] 3.4	25.0 [7.33] 3.5
	30 [-1.1]	Total BTUH [kW] Power	31.7 [9.29] 2.7	31.3 [9.17] 2.8	30.8 [9.03] 2.8	30.4 [8.91] 3.0	29.9 [8.76] 3.1	29.5 [8.65] 3.2	29.0 [8.50] 3.4	28.6 [8.38] 3.5	28.2 [8.26] 3.6
	35 [1.7]	Total BTUH [kW] Power	35.0 [10.26] 2.8	34.5 [10.11] 2.8	34.0 [9.96] 2.9	33.7 [9.88] 3.1	33.2 [9.73] 3.2	32.7 [9.58] 3.2	32.3 [9.47] 3.4	31.9 [9.35] 3.5	31.4 [9.20] 3.6
	40 [4.4]	Total BTUH [kW] Power	38.3 [11.22] 2.8	37.8 [11.08] 2.9	37.3 [10.93] 3.0	37.0 [10.84] 3.1	36.5 [10.70] 3.2	36.0 [10.55] 3.3	35.6 [10.43] 3.5	35.1 [10.29] 3.6	34.6 [10.14] 3.7
	45 [7.2]	Total BTUH [kW] Power	41.7 [12.22] 2.9	41.1 [12.05] 2.9	40.5 [11.87] 3.0	40.3 [11.81] 3.2	39.7 [11.63] 3.3	39.2 [11.49] 3.4	39.0 [11.43] 3.6	38.4 [11.25] 3.7	37.9 [11.11] 3.8
50 [10]	Total BTUH [kW] Power	45.0 [13.19] 2.9	44.3 [12.98] 3.0	43.7 [12.81] 3.1	43.6 [12.78] 3.3	43.0 [12.60] 3.3	42.4 [12.43] 3.4	42.3 [12.40] 3.6	41.7 [12.22] 3.7	41.1 [12.05] 3.8	

IDB—Indoor air dry bulb

HEATING PERFORMANCE DATA—RQPM-A049JK

IDB		60°F [15.5°C]			70°F [21.1°C]			80°F [26.7°C]			
CFM [L/s]		1860 [878]	1550 [732]	1240 [585]	1860 [878]	1550 [732]	1240 [585]	1860 [878]	1550 [732]	1240 [585]	
OUTDOOR DRY BULB TEMPERATURE °F [°C]	0 [-17.8]	Total BTUH [kW] Power	25.9 [7.59] 2.2	25.5 [7.47] 2.3	25.1 [7.36] 2.4	24.5 [7.18] 2.6	24.2 [7.09] 2.7	23.8 [6.98] 2.7	23.1 [6.77] 2.9	22.8 [6.68] 3.0	22.5 [6.59] 3.0
	5 [-15]	Total BTUH [kW] Power	27.7 [8.12] 2.3	27.3 [8.00] 2.4	26.9 [7.88] 2.4	26.3 [7.71] 2.7	26.0 [7.62] 2.7	25.6 [7.50] 2.8	25.0 [7.33] 3.0	24.6 [7.21] 3.0	24.2 [7.09] 3.1
	10 [-12.2]	Total BTUH [kW] Power	29.5 [8.65] 2.4	29.1 [8.53] 2.4	28.7 [8.41] 2.5	28.1 [8.24] 2.7	27.8 [8.15] 2.8	27.4 [8.03] 2.9	26.8 [7.85] 3.0	26.4 [7.74] 3.1	26.0 [7.62] 3.2
	15 [-9.4]	Total BTUH [kW] Power	31.3 [9.17] 2.4	30.9 [9.06] 2.5	30.5 [8.94] 2.6	30.0 [8.79] 2.8	29.5 [8.65] 2.9	29.1 [8.53] 3.0	28.6 [8.38] 3.1	28.2 [8.26] 3.2	27.8 [8.15] 3.3
	20 [-6.7]	Total BTUH [kW] Power	33.2 [9.73] 2.5	32.7 [9.58] 2.6	32.2 [9.44] 2.6	31.8 [9.32] 2.9	31.3 [9.17] 2.9	30.9 [9.06] 3.0	30.4 [8.91] 3.2	30.0 [8.79] 3.2	29.6 [8.67] 3.3
	25 [-3.9]	Total BTUH [kW] Power	35.0 [10.26] 2.6	34.5 [10.11] 2.6	34.0 [9.96] 2.7	33.6 [9.85] 2.9	33.1 [9.70] 3.0	32.7 [9.58] 3.1	32.2 [9.44] 3.2	31.8 [9.32] 3.3	31.3 [9.17] 3.4
	30 [-1.1]	Total BTUH [kW] Power	36.8 [10.79] 2.6	36.3 [10.64] 2.7	35.8 [10.49] 2.8	35.4 [10.37] 3.0	34.9 [10.23] 3.1	34.4 [10.08] 3.2	34.1 [9.99] 3.3	33.6 [9.85] 3.4	33.1 [9.70] 3.5
	35 [1.7]	Total BTUH [kW] Power	38.6 [11.31] 2.7	38.1 [11.17] 2.8	37.5 [10.99] 2.8	37.3 [10.93] 3.1	36.7 [10.76] 3.2	36.2 [10.61] 3.2	35.9 [10.52] 3.4	35.4 [10.37] 3.4	34.9 [10.23] 3.5
	40 [4.4]	Total BTUH [kW] Power	40.5 [11.87] 2.8	39.9 [11.69] 2.8	39.3 [11.52] 2.9	39.1 [11.46] 3.1	38.5 [11.28] 3.2	38.0 [11.14] 3.3	37.7 [11.05] 3.4	37.2 [10.90] 3.5	36.6 [10.73] 3.6
	45 [7.2]	Total BTUH [kW] Power	42.3 [12.40] 2.8	41.7 [12.22] 2.9	41.1 [12.05] 3.0	40.9 [11.99] 3.2	40.3 [11.81] 3.3	39.7 [11.63] 3.4	39.5 [11.58] 3.5	39.0 [11.43] 3.6	38.4 [11.25] 3.7
50 [10]	Total BTUH [kW] Power	44.1 [12.92] 2.9	43.5 [12.75] 3.0	42.9 [12.57] 3.0	42.7 [12.51] 3.3	42.1 [12.34] 3.4	41.5 [12.16] 3.4	41.3 [12.10] 3.6	40.8 [11.96] 3.6	40.2 [11.78] 3.7	

IDB—Indoor air dry bulb

[] Designates Metric Conversions



HEATING PERFORMANCE DATA—RQPM-A060

IDB		60°F [15.5°C]			70°F [21.1°C]			80°F [26.7°C]			
CFM [L/s]		2280 [1076]	1900 [897]	1520 [717]	2280 [1076]	1900 [897]	1520 [717]	2280 [1076]	1900 [897]	1520 [717]	
OUTDOOR DRY BULB TEMPERATURE	0 [-17.8]	Total BTUH [kW] Power	22.8 [6.68] 2.9	22.5 [6.59] 2.9	22.2 [6.51] 3.0	21.6 [6.33] 3.4	21.3 [6.24] 3.5	21.0 [6.15] 3.5	20.3 [5.95] 3.9	20.0 [5.86] 4.0	19.7 [5.77] 4.1
	5 [-15]	Total BTUH [kW] Power	26.7 [7.83] 3.0	26.3 [7.71] 3.0	25.9 [7.59] 3.1	25.5 [7.47] 3.5	25.1 [7.36] 3.5	24.8 [7.27] 3.6	24.2 [7.09] 4.0	23.8 [6.98] 4.1	23.5 [6.89] 4.2
	10 [-12.2]	Total BTUH [kW] Power	30.6 [8.97] 3.0	30.2 [8.85] 3.1	29.7 [8.70] 3.2	29.4 [8.62] 3.5	29.0 [8.50] 3.6	28.6 [8.38] 3.7	28.1 [8.24] 4.1	27.7 [8.12] 4.2	27.3 [8.00] 4.3
	15 [-9.4]	Total BTUH [kW] Power	34.5 [10.11] 3.1	34.0 [9.96] 3.2	33.6 [9.85] 3.3	33.3 [9.76] 3.6	32.8 [9.61] 3.7	32.4 [9.50] 3.8	32.0 [9.38] 4.1	31.6 [9.26] 4.2	31.1 [9.11] 4.4
	20 [-6.7]	Total BTUH [kW] Power	38.5 [11.28] 3.2	37.9 [11.11] 3.3	37.4 [10.96] 3.4	37.2 [10.90] 3.7	36.7 [10.76] 3.8	36.2 [10.61] 3.9	35.9 [10.52] 4.2	35.4 [10.37] 4.3	34.9 [10.23] 4.4
	25 [-3.9]	Total BTUH [kW] Power	42.4 [12.43] 3.3	41.8 [12.25] 3.4	41.2 [12.07] 3.5	41.2 [12.07] 3.8	40.6 [11.90] 3.9	40.0 [11.72] 4.0	39.9 [11.69] 4.3	39.3 [11.52] 4.4	38.8 [11.37] 4.5
	30 [-1.1]	Total BTUH [kW] Power	46.4 [13.60] 3.4	45.7 [13.39] 3.5	45.0 [13.19] 3.5	45.1 [13.22] 3.9	44.5 [13.04] 4.0	43.9 [12.87] 4.1	43.8 [12.84] 4.4	43.2 [12.66] 4.5	42.6 [12.48] 4.6
	35 [1.7]	Total BTUH [kW] Power	50.3 [14.74] 3.4	49.6 [14.54] 3.5	48.9 [14.33] 3.6	49.1 [14.39] 3.9	48.4 [14.18] 4.0	47.7 [13.98] 4.1	47.8 [14.01] 4.5	47.1 [13.80] 4.6	46.5 [13.63] 4.7
	40 [4.4]	Total BTUH [kW] Power	54.3 [15.91] 3.5	53.5 [15.68] 3.6	52.8 [15.47] 3.7	53.1 [15.56] 4.0	52.3 [15.33] 4.1	51.6 [15.12] 4.2	51.8 [15.18] 4.5	51.1 [14.98] 4.7	50.3 [14.74] 4.8
	45 [7.2]	Total BTUH [kW] Power	58.3 [17.09] 3.6	57.5 [16.85] 3.7	56.7 [16.62] 3.8	57.1 [16.73] 4.1	56.3 [16.50] 4.2	55.5 [16.27] 4.3	55.8 [16.35] 4.6	55.0 [16.12] 4.7	54.2 [15.88] 4.9
50 [10]	Total BTUH [kW] Power	62.3 [18.26] 3.7	61.4 [17.99] 3.8	60.6 [17.76] 3.9	61.1 [17.91] 4.2	60.2 [17.64] 4.3	59.4 [17.41] 4.4	59.8 [17.53] 4.7	58.9 [17.26] 4.8	58.1 [17.03] 5.0	

IDB—Indoor air dry bulb

[] Designates Metric Conversions



INDOOR AIRFLOW PERFORMANCE—230 VOLTS

Nominal Cooling Capacity Tons [kW]	Motor Speed from Factory	Manufacturer Recommended Air-Flow Range (Min/Max) CFM	Blower Size/ Motor HP [W] & # of Speeds	Motor Speed	CFM [L/s] Air Delivery/RPM/Watts—230 Volts Side Discharge—Wet Coil											
					External Static Pressure—Inches W.C. [kPa]											
					0.1 [0.2]	0.2 [0.05]	0.3 [0.07]	0.4 [0.10]	0.5 [0.12]	0.6 [0.15]	0.7 [0.17]	0.8 [0.20]	0.9 [0.22]	1.0 [0.25]		
2.0 [7.03]	Low	700/900	10x9 1/4 HP [186] 2 Speed (PSC Motor)	Low	CFM	827 [390]	811 [383]	782 [369]	740 [349]	684 [323]	614 [290]	531 [251]	435 [205]	—	—	
					RPM	450	533	626	742	799	894	932	985	—	—	
					Watts	278	273	269	254	244	227	216	198	—	—	
	High	CFM	1230 [580]	1223 [577]	1216 [574]	1211 [572]	1187 [560]	1125 [531]	1020 [481]	874 [412]	696 [328]	504 [238]	1092	—		
		RPM	575	643	703	767	819	877	976	1001	1072	1092	—	—		
		Watts	479	468	455	448	431	416	357	341	279	259	—	—		
2.5 [8.79]	Low	875/1125	10x9 1/3 HP [249] 2 Speed (PSC Motor)	Low	CFM	1032 [487]	1030 [486]	1014 [478]	979 [462]	923 [436]	843 [398]	735 [347]	596 [281]	423 [200]	—	
					RPM	533	570	659	746	795	863	934	1019	1050	—	—
					Watts	336	331	326	314	303	280	271	227	210	—	—
	High	CFM	1312 [619]	1301 [614]	1292 [610]	1276 [602]	1246 [588]	1196 [564]	1117 [527]	1003 [473]	845 [399]	—	—	—		
		RPM	592	646	712	768	824	883	933	1012	1035	—	—	—		
		Watts	482	473	466	454	433	421	401	349	329	—	—	—		
3.0 [10.55]	Low	1050/1350	10x9 1/2 HP [373] 2 Speed (PSC Motor)	Low	CFM	1261 [595]	1253 [591]	1225 [578]	1177 [555]	1110 [524]	1023 [483]	915 [432]	788 [372]	641 [303]	—	
					RPM	648	705	754	802	854	896	985	1008	1041	—	—
					Watts	398	395	387	391	370	361	323	310	300	—	—
	High	CFM	2068 [976]	2008 [948]	1957 [924]	1905 [899]	1841 [869]	1753 [827]	1629 [769]	1458 [688]	1228 [580]	929 [438]	1108	—		
		RPM	850	883	917	946	972	999	1028	1049	1091	1108	—	—		
		Watts	826	806	784	762	734	702	658	626	546	512	—	—		
3.5 [12.31]	Low	1225/1575	11x9 1/2 HP [373] 2 Speed (PSC Motor)	Low	CFM	1431 [675]	1394 [658]	1348 [636]	1302 [614]	1258 [594]	1208 [570]	1140 [538]	1030 [486]	849 [401]	577 [263]	
					RPM	540	579	633	686	724	776	831	868	1035	1076	
					Watts	482	479	477	470	459	453	437	423	335	292	
	High	CFM	1960 [925]	1936 [914]	1903 [898]	1859 [877]	1806 [852]	1742 [822]	1669 [788]	1585 [748]	1491 [704]	1387 [655]	975	—		
		RPM	703	727	750	780	809	846	877	910	940	975	—	—		
		Watts	783	782	776	759	750	729	712	686	666	625	—	—		
4.0 [14.07]	Low	1400/1800	11x9 3/4 HP [559] 2 Speed (PSC Motor)	Low	CFM	1674 [790]	1638 [773]	1595 [753]	1547 [730]	1492 [704]	1432 [676]	1365 [644]	1293 [610]	1214 [573]	1129 [533]	
					RPM	576	618	668	708	753	789	832	874	915	954	
					Watts	575	563	556	549	544	532	522	503	483	465	
	High	CFM	1996 [942]	1976 [933]	1947 [919]	1909 [901]	1863 [879]	1808 [853]	1744 [823]	1671 [789]	1590 [750]	1500 [708]	973	—		
		RPM	680	722	752	781	807	833	867	912	936	973	—	—		
		Watts	799	787	784	760	753	749	730	699	693	652	—	—		
5.0 [17.6]	Low	1750/2250	11x9 3/4 HP [559] 2 Speed (PSC Motor)	Low	CFM	2044 [965]	2017 [952]	1993 [936]	1941 [916]	1892 [893]	1836 [866]	1773 [837]	1702 [803]	1623 [766]	1537 [725]	
					RPM	689	723	756	798	822	855	889	924	951	988	
					Watts	886	870	865	849	831	817	799	782	755	726	
	High	CFM	2693 [1271]	2654 [1253]	2606 [1230]	2549 [1203]	2483 [1172]	2408 [1136]	2323 [1096]	2230 [1052]	2127 [1004]	2015 [951]	1044	—		
		RPM	876	897	915	938	956	975	996	1009	1025	1044	—	—		
		Watts	1438	1427	1399	1368	1340	1312	1274	1228	1192	1146	—	—		

[] Designates Metric Conversions



INDOOR AIRFLOW PERFORMANCE—208 VOLTS

Nominal Cooling Capacity Tons [kW]	Motor Speed from Factory	Manufacturer Recommended Air-Flow Range (Min/Max) CFM	Blower Size/ Motor HP [W] & # of Speeds	Motor Speed	CFM [L/s] Air Delivery/RPM/Watts—208 Volts Side Discharge—Wet Coil																					
					External Static Pressure—Inches W.C. [kPa]																					
					0.1 [0.02]	0.2 [0.05]	0.3 [0.07]	0.4 [0.10]	0.5 [0.12]	0.6 [0.15]	0.7 [0.17]	0.8 [0.20]	0.9 [0.22]	1.0 [0.25]												
2.0 [7.03]	Low	700/900	10x9 1/4 HP [186] 2 Speed (PSC Motor)	Low	CFM	723 [341]	692 [327]	654 [309]	609 [287]	556 [262]	496 [234]	428 [202]	—	—	—	—	—	—	—	—	—	—				
					RPM	443	528	651	710	819	863	914	—	—	—	—	—	—	—	—	—	—	—	—		
					Watts	230	222	219	214	202	196	184	—	—	—	—	—	—	—	—	—	—	—	—	—	
	High	700/900	10x9 1/4 HP [186] 2 Speed (PSC Motor)	High	CFM	1062 [501]	1062 [501]	1058 [499]	1043 [492]	1013 [478]	962 [454]	884 [417]	774 [365]	627 [296]	437 [206]	—	—	—	—	—	—	—	—			
					RPM	528	618	674	735	812	895	936	—	—	—	—	—	—	—	—	—	—	—	—		
					Watts	396	393	384	376	361	335	318	—	—	—	—	—	—	—	—	—	—	—	—	—	
2.5 [8.79]	Low	875/1125	10x9 1/3 HP [249] 2 Speed (PSC Motor)	Low	CFM	923 [435]	904 [426]	874 [413]	832 [393]	774 [365]	698 [329]	602 [284]	483 [228]	—	—	—	—	—	—	—	—	—	—			
					RPM	498	543	648	728	806	853	947	—	—	—	—	—	—	—	—	—	—	—	—	—	
					Watts	280	278	268	259	252	243	219	—	—	—	—	—	—	—	—	—	—	—	—	—	
	High	875/1125	10x9 1/3 HP [249] 2 Speed (PSC Motor)	High	CFM	1164 [549]	1154 [545]	1143 [539]	1124 [530]	1090 [514]	1034 [489]	948 [447]	826 [390]	660 [311]	445 [210]	—	—	—	—	—	—	—	—	—		
					RPM	526	596	670	744	803	864	945	—	—	—	—	—	—	—	—	—	—	—	—	—	
					Watts	401	398	388	379	371	350	322	—	—	—	—	—	—	—	—	—	—	—	—	—	—
3.0 [10.55]	Low	1050/1350	10x9 1/2 HP [373] 2 Speed (PSC Motor)	Low	CFM	1145 [540]	1142 [539]	1118 [528]	1073 [506]	1006 [475]	918 [433]	—	—	—	—	—	—	—	—	—	—	—	—			
					RPM	556	645	703	769	828	909	—	—	—	—	—	—	—	—	—	—	—	—	—	—	
					Watts	346	340	335	326	321	298	—	—	—	—	—	—	—	—	—	—	—	—	—	—	—
	High	1050/1350	10x9 1/2 HP [373] 2 Speed (PSC Motor)	High	CFM	1884 [889]	1850 [873]	1815 [856]	1772 [836]	1712 [808]	1630 [769]	1516 [715]	1363 [643]	1164 [549]	910 [430]	—	—	—	—	—	—	—	—	—		
					RPM	791	834	871	912	946	975	1004	—	—	—	—	—	—	—	—	—	—	—	—	—	
					Watts	704	694	675	655	638	606	581	—	—	—	—	—	—	—	—	—	—	—	—	—	—
3.5 [12.31]	Low	1225/1575	11x9 1/2 HP [373] 2 Speed (PSC Motor)	Low	CFM	1279 [604]	1237 [584]	1196 [564]	1151 [543]	1098 [518]	1032 [487]	950 [448]	846 [399]	717 [338]	558 [263]	—	—	—	—	—	—	—	—	—		
					RPM	490	539	598	653	709	772	811	—	—	—	—	—	—	—	—	—	—	—	—	—	
					Watts	401	400	393	391	381	373	364	—	—	—	—	—	—	—	—	—	—	—	—	—	—
	High	1225/1575	11x9 1/2 HP [373] 2 Speed (PSC Motor)	High	CFM	1751 [826]	1729 [816]	1698 [801]	1658 [782]	1608 [759]	1549 [731]	1481 [699]	1404 [663]	1317 [622]	1221 [576]	—	—	—	—	—	—	—	—	—		
					RPM	640	668	706	734	781	813	851	—	—	—	—	—	—	—	—	—	—	—	—	—	
					Watts	660	658	651	644	628	617	603	—	—	—	—	—	—	—	—	—	—	—	—	—	—
4.0 [14.07]	Low	1400/1800	11x9 3/4 HP [559] 2 Speed (PSC Motor)	Low	CFM	1400 [661]	1393 [658]	1373 [648]	1337 [631]	1288 [608]	1225 [578]	1147 [541]	1055 [498]	949 [448]	828 [391]	—	—	—	—	—	—	—	—	—		
					RPM	536	578	623	677	718	782	830	—	—	—	—	—	—	—	—	—	—	—	—	—	—
					Watts	471	466	458	455	453	442	429	—	—	—	—	—	—	—	—	—	—	—	—	—	—
	High	1400/1800	11x9 3/4 HP [559] 2 Speed (PSC Motor)	High	CFM	1786 [843]	1764 [832]	1734 [818]	1695 [800]	1649 [778]	1595 [753]	1532 [723]	1462 [690]	1384 [653]	1297 [612]	—	—	—	—	—	—	—	—	—		
					RPM	618	643	684	726	757	805	841	—	—	—	—	—	—	—	—	—	—	—	—	—	
					Watts	665	660	651	646	638	626	612	—	—	—	—	—	—	—	—	—	—	—	—	—	—
5.0 [17.6]	Low	1750/2250	11x9 3/4 HP [559] 2 Speed (PSC Motor)	Low	CFM	1848 [872]	1821 [859]	1785 [843]	1742 [822]	1690 [798]	1630 [769]	1562 [737]	1486 [701]	1402 [662]	1309 [618]	—	—	—	—	—	—	—	—	—		
					RPM	660	685	722	755	795	836	867	—	—	—	—	—	—	—	—	—	—	—	—	—	—
					Watts	731	725	720	707	698	680	665	—	—	—	—	—	—	—	—	—	—	—	—	—	—
	High	1750/2250	11x9 3/4 HP [559] 2 Speed (PSC Motor)	High	CFM	2444 [1153]	2420 [1142]	2384 [1125]	2337 [1103]	2278 [1075]	2208 [1042]	2127 [1004]	2034 [960]	1930 [911]	1814 [856]	—	—	—	—	—	—	—	—	—		
					RPM	829	838	863	885	914	936	958	—	—	—	—	—	—	—	—	—	—	—	—	—	
					Watts	1225	1218	1197	1191	1160	1135	1105	—	—	—	—	—	—	—	—	—	—	—	—	—	—

[J Designates Metric Conversions



INDOOR AIRFLOW PERFORMANCE—230 VOLTS

Nominal Cooling Capacity Tons [kW]	Motor Speed from Factory	Manufacturer Recommended Air-Flow Range (Min/Max) CFM	Blower Size/ Motor HP [W] & # of Speeds	Motor Speed	CFM [L/s] Air Delivery/RPM/Watts—230 Volts Side Discharge—Wet Coil										
					External Static Pressure—Inches W.C. [kPa]										
					0.1 [.02]	0.2 [.05]	0.3 [.07]	0.4 [.10]	0.5 [.12]	0.6 [.15]	0.7 [.17]	0.8 [.20]	0.9 [.22]	1.0 [.25]	
2.0 [7.03]	Low (Tap 2)	700/900	10x9 1/4 HP [186] 2 Speed X-13 (ECM) Motor	Low (Tap 2)	CFM	939 [443]	877 [414]	816 [385]	754 [356]	693 [327]	631 [298]	570 [269]	508 [240]	447 [211]	—
					RPM	585	601	655	744	809	860	915	1001	1043	—
					Watts	131	116	97	110	121	126	136	149	152	—
2.5 [8.79]	Low (Tap 2)	875/1125	10x9 1/3 HP [249] 2 Speed X-13 (ECM) Motor	High (Tap 1)	CFM	1240 [585]	1184 [559]	1127 [532]	1071 [505]	1014 [479]	958 [452]	901 [425]	845 [399]	788 [372]	732 [345]
					RPM	607	634	698	761	815	880	946	989	1038	1091
					Watts	161	145	159	173	182	196	210	220	231	237
3.0 [10.55]	Low (Tap 2)	1050/1350	10x9 1/2 HP [373] 2 Speed X-13 (ECM) Motor	Low (Tap 2)	CFM	1169 [552]	1109 [523]	1049 [495]	988 [466]	928 [438]	868 [410]	807 [381]	747 [353]	687 [324]	626 [295]
					RPM	603	619	693	756	809	893	942	989	1034	1076
					Watts	144	130	138	151	159	174	185	195	199	209
3.5 [12.31]	Low (Tap 2)	1050/1350	10x9 1/2 HP [373] 2 Speed X-13 (ECM) Motor	High (Tap 1)	CFM	1365 [644]	1316 [621]	1266 [597]	1217 [574]	1168 [551]	1119 [528]	1069 [505]	1020 [481]	971 [458]	922 [435]
					RPM	631	677	732	784	843	894	942	1035	1077	1118
					Watts	177	190	204	218	234	247	256	279	289	294
4.0 [14.07]	Low (Tap 2)	1225/1575	11x9 1/2 HP [373] 2 Speed X-13 (ECM) Motor	Low (Tap 2)	CFM	1328 [627]	1280 [604]	1231 [581]	1183 [558]	1135 [536]	1086 [513]	1038 [490]	990 [467]	941 [444]	893 [421]
					RPM	648	697	752	807	857	903	989	1036	1077	1114
					Watts	178	191	206	220	233	246	265	277	286	291
5.0 [17.6]	Low (Tap 2)	1400/1800	11x9 3/4 HP [559] 2 Speed X-13 (ECM) Motor	High (Tap 1)	CFM	1510 [713]	1464 [691]	1418 [669]	1373 [648]	1327 [626]	1281 [605]	1235 [583]	1190 [562]	1144 [540]	1098 [518]
					RPM	707	743	792	841	890	921	981	1031	1114	1151
					Watts	248	261	277	292	307	322	334	348	366	358
5.0 [17.6]	Low (Tap 2)	1400/1800	11x9 3/4 HP [559] 2 Speed X-13 (ECM) Motor	Low (Tap 2)	CFM	1542 [728]	1490 [703]	1438 [679]	1386 [654]	1335 [630]	1283 [606]	1231 [581]	1180 [557]	1128 [532]	1076
					RPM	598	617	662	714	758	800	849	876	913	951
					Watts	244	231	237	254	270	285	304	313	326	340
5.0 [17.6]	Low (Tap 2)	1750/2250	11x9 3/4 HP [559] 2 Speed X-13 (ECM) Motor	High (Tap 1)	CFM	1740 [821]	1695 [800]	1649 [778]	1604 [757]	1558 [735]	1513 [714]	1467 [692]	1422 [671]	1376 [649]	1331 [628]
					RPM	632	665	709	749	797	833	879	917	951	981
					Watts	295	311	331	350	371	386	409	426	440	454
5.0 [17.6]	Low (Tap 2)	1750/2250	11x9 3/4 HP [559] 2 Speed X-13 (ECM) Motor	Low (Tap 2)	CFM	1701 [803]	1655 [781]	1609 [759]	1563 [738]	1517 [716]	1471 [694]	1425 [673]	1379 [651]	1333 [629]	1287 [607]
					RPM	624	648	696	743	787	826	863	895	934	970
					Watts	280	287	309	328	347	363	380	392	410	426
5.0 [17.6]	Low (Tap 2)	1750/2250	11x9 3/4 HP [559] 2 Speed X-13 (ECM) Motor	High (Tap 1)	CFM	1921 [907]	1878 [886]	1835 [866]	1792 [846]	1749 [825]	1706 [805]	1663 [785]	1620 [765]	1577 [744]	1534 [724]
					RPM	678	706	738	776	816	865	899	932	967	994
					Watts	385	400	416	439	458	484	501	517	537	550
5.0 [17.6]	Low (Tap 2)	1750/2250	11x9 3/4 HP [559] 2 Speed X-13 (ECM) Motor	Low (Tap 2)	CFM	1986 [937]	1945 [918]	1905 [899]	1864 [880]	1823 [860]	1782 [841]	1741 [822]	1700 [802]	1659 [783]	1618 [764]
					RPM	731	759	792	832	871	909	943	979	1014	1055
					Watts	446	458	477	499	521	543	562	582	600	621
5.0 [17.6]	Low (Tap 2)	1750/2250	11x9 3/4 HP [559] 2 Speed X-13 (ECM) Motor	High (Tap 1)	CFM	2229 [1052]	2190 [1034]	2152 [1016]	2114 [998]	2075 [979]	2037 [961]	1999 [943]	1960 [925]	1922 [907]	1884 [889]
					RPM	795	824	851	882	919	952	983	1013	1045	1077
					Watts	619	638	658	680	703	724	745	764	784	804

[] Designates Metric Conversions



INDOOR AIRFLOW PERFORMANCE—208 VOLTS

Nominal Cooling Capacity Tons [kW]	Motor Speed from Factory	Manufacturer Recommended Air-Flow Range (Min/Max) CFM	Blower Size/ Motor HP [W] & # of Speeds	Motor Speed	CFM [L/s] Air Delivery/RPM/Watts—208 Volts Site Discharge—Wet Coil										
					External Static Pressure—Inches W.C. [kPa]										
					0.1 [0.2]	0.2 [0.05]	0.3 [0.07]	0.4 [0.10]	0.5 [0.12]	0.6 [0.15]	0.7 [0.17]	0.8 [0.20]	0.9 [0.22]	1.0 [0.25]	
2.0 [7.03]	Low (Tap 2)	700/900	10x9 1/4 HP [186] 2 Speed X-13 (ECM) Motor	Low (Tap 2)	CFM	959 [453]	892 [421]	825 [389]	758 [358]	691 [326]	624 [294]	557 [263]	491 [232]	—	—
				RPM	582	606	655	723	808	851	906	996	—	—	
				Watts	132	110	96	106	119	123	132	144	—	—	
2.5 [8.79]	Low (Tap 2)	875/1125	10x9 1/3 HP [249] 2 Speed X-13 (ECM) Motor	High (Tap 1)	CFM	1229 [580]	1170 [552]	1112 [525]	1054 [497]	996 [470]	938 [443]	879 [415]	821 [387]	763 [360]	705 [333]
				RPM	607	634	698	761	815	880	946	989	1038	1091	
				Watts	161	145	159	173	182	196	210	220	231	237	
3.0 [10.55]	Low (Tap 2)	1050/1350	10x9 1/2 HP [373] 2 Speed X-13 (ECM) Motor	Low (Tap 2)	CFM	1162 [548]	1099 [519]	1035 [488]	972 [459]	908 [429]	844 [398]	717 [369]	654 [309]	590 [278]	
				RPM	603	626	690	752	815	906	941	984	1027	1096	
				Watts	143	124	136	148	157	175	180	188	192	202	
3.5 [12.31]	Low (Tap 2)	1225/1575	11x9 1/2 HP [373] 2 Speed X-13 (ECM) Motor	High (Tap 1)	CFM	1306 [616]	1253 [591]	1200 [566]	1147 [541]	1095 [517]	1042 [492]	989 [467]	937 [442]	884 [417]	831 [392]
				RPM	632	679	733	787	841	883	941	1035	1067	1099	
				Watts	174	187	201	215	227	235	248	266	273	277	
4.0 [14.07]	Low (Tap 2)	1400/1800	11x9 3/4 HP [559] 2 Speed X-13 (ECM) Motor	Low (Tap 2)	CFM	1328 [627]	1276 [602]	1223 [577]	1171 [553]	1118 [528]	1066 [503]	1013 [478]	961 [454]	—	—
				RPM	642	693	747	803	852	903	988	1031	—	—	
				Watts	173	187	200	214	226	238	254	263	—	—	
5.0 [17.6]	Low (Tap 2)	1750/2250	11x9 3/4 HP [559] 2 Speed X-13 (ECM) Motor	High (Tap 1)	CFM	1508 [712]	1459 [689]	1409 [665]	1359 [641]	1310 [618]	1260 [595]	1210 [571]	1160 [547]	1111 [524]	1061 [501]
				RPM	698	738	789	839	888	933	983	1035	1103	1137	
				Watts	243	255	271	285	299	310	322	332	343	343	
5.0 [17.6]	Low (Tap 2)	1750/2250	11x9 3/4 HP [559] 2 Speed X-13 (ECM) Motor	Low (Tap 2)	CFM	1531 [723]	1477 [697]	1423 [672]	1370 [647]	1316 [621]	1262 [596]	1208 [570]	1154 [545]	1101 [520]	1047 [494]
				RPM	602	619	668	715	757	801	844	878	918	954	
				Watts	238	227	236	251	266	281	296	307	320	333	
5.0 [17.6]	Low (Tap 2)	1750/2250	11x9 3/4 HP [559] 2 Speed X-13 (ECM) Motor	High (Tap 1)	CFM	1724 [814]	1678 [792]	1632 [770]	1586 [749]	1540 [727]	1495 [706]	1449 [684]	1403 [662]	1357 [640]	1311 [619]
				RPM	639	671	715	759	794	834	875	911	948	977	
				Watts	295	309	330	348	363	380	397	414	429	440	
5.0 [17.6]	Low (Tap 2)	1750/2250	11x9 3/4 HP [559] 2 Speed X-13 (ECM) Motor	Low (Tap 2)	CFM	1708 [806]	1658 [782]	1609 [759]	1559 [736]	1510 [713]	1460 [689]	1410 [665]	1361 [642]	1311 [619]	1262 [596]
				RPM	619	651	686	741	783	822	859	894	937	971	
				Watts	280	284	298	323	339	355	370	385	402	415	
5.0 [17.6]	Low (Tap 2)	1750/2250	11x9 3/4 HP [559] 2 Speed X-13 (ECM) Motor	High (Tap 1)	CFM	1917 [905]	1872 [883]	1827 [862]	1782 [841]	1736 [819]	1691 [798]	1646 [777]	1601 [756]	1556 [734]	1510 [713]
				RPM	673	702	736	769	818	860	898	928	960	989	
				Watts	377	392	409	426	451	473	490	504	518	531	
5.0 [17.6]	Low (Tap 2)	1750/2250	11x9 3/4 HP [559] 2 Speed X-13 (ECM) Motor	Low (Tap 2)	CFM	1954 [922]	1914 [903]	1874 [884]	1833 [865]	1793 [846]	1753 [827]	1713 [808]	1673 [790]	1632 [770]	1592 [751]
				RPM	719	747	779	818	857	894	928	963	998	1038	
				Watts	439	451	469	491	512	534	553	573	590	611	
5.0 [17.6]	Low (Tap 2)	1750/2250	11x9 3/4 HP [559] 2 Speed X-13 (ECM) Motor	High (Tap 1)	CFM	2173 [1026]	2136 [1008]	2098 [990]	2061 [973]	2024 [955]	1986 [937]	1949 [920]	1911 [902]	1874 [884]	1837 [867]
				RPM	775	803	830	860	896	928	959	988	1019	1050	
				Watts	604	622	642	663	686	706	727	745	765	784	

[J Designates Metric Conversions



ELECTRICAL DATA – RQNM SERIES

		-A024JK	-A030JK	-A036CK	-A036JK	-A042CK	-A042JK	-A048CK	-A048JK	-A060CK	-A060JK
Unit Information	Unit Operating Voltage Range	187-253	187-253	187-253	187-253	187-253	187-253	187-253	187-253	187-253	187-253
	Minimum Circuit Ampacity	20/20	21/21	17/17	25/25	23/23	33/33	23/23	33/33	31/31	41/41
	Minimum Overcurrent Protection Device Size	25/25	25/25	20/20	30/30	30/30	40/40	30/30	40/40	35/35	50/50
	Maximum Overcurrent Protection Device Size	30/30	35/35	25/25	40/40	35/35	50/50	35/35	50/50	45/45	60/60
Compressor Motor	No.	1	1	1	1	1	1	1	1	1	1
	Volts	208/230	208/230	208/230	208/230	208/230	208/230	208/230	208/230	208/230	208/230
	Phase	1	1	3	1	3	1	3	1	3	1
	HP	2	2.5	3	3	3.5	3.5	4	4	4.5	4.5
	RPM	3450	3450	3450	3450	3450	3450	3450	3450	3450	3450
	Amps (RLA)	13.5/13.5	14.1/14.1	10.4/10.4	16.7/16.7	14.1/14.1	21.8/21.8	13.7/13.7	21.8/21.8	17.9/17.9	26.4/26.4
	Amps (LRA)	58.3/58.3	73/73	88/88	79/79	95/95	112/112	83.1/83.1	117/117	120/120	150/150
Condenser Motor	No.	1	1	1	1	1	1	1	1	1	1
	Volts	208/230	208/230	208/230	208/230	208/230	208/230	208/230	208/230	208/230	208/230
	Phase	1	1	1	1	1	1	1	1	1	1
	HP	1/3	1/3	1/3	1/3	1/3	1/3	1/3	1/3	1/3	1/3
	Amps (FLA)	1.5	1.5	1.5	1.5	1.9	1.9	1.9	1.9	1.9	1.9
	Amps (LRA)	3	3	3	3	4	4	4	4	4	4
Evaporator Fan	No.	1	1	1	1	1	1	1	1	1	1
	Volts	208/230	208/230	208/230	208/230	208/230	208/230	208/230	208/230	208/230	208/230
	Phase	1	1	1	1	1	1	1	1	1	1
	HP	1/4	1/3	1/2	1/2	1/2	1/2	3/4	3/4	3/4	3/4
	Amps (FLA)	1.5	1.7	2.5	2.5	2.7	2.7	3.2	3.2	5.8	5.8
	Amps (LRA)	2.6	2.6	5	5	4.6	4.6	4.4	4.4	11.3	11.3



ELECTRICAL DATA – RQPM SERIES								
		-A024JK	-A030JK	-A036CK	-A036JK	-A037CK	-A037JK	-A042CK
Unit Information	Unit Operating Voltage Range	187-253	187-253	187-253	187-253	187-253	187-253	187-253
	Minimum Circuit Ampacity	23/23	21/21	19/19	27/27	19/19	27/27	26/26
	Minimum Overcurrent Protection Device Size	30/30	30/30	25/25	35/35	25/25	35/35	30/30
	Maximum Overcurrent Protection Device Size	35/35	35/35	25/25	40/40	25/25	40/40	35/35
Compressor Motor	No.	1	1	1	1	1	1	1
	Volts	208/230	208/230	208/230	208/230	208/230	208/230	208/230
	Phase	1	1	3	1	3	1	3
	HP	2	2.5	3	3	3	3	3.5
	RPM	3450	3450	3450	3450	3450	3450	3450
	Amps (RLA)	13.5/13.5	14.1/14.1	10.4/10.4	16.7/16.7	10.4/10.4	16.7/16.7	14.1/14.1
	Amps (LRA)	58.3/58.3	73/73	88/88	79/79	88/88	79/79	95/95
Condenser Motor	No.	1	1	1	1	1	1	1
	Volts	208/230	208/230	208/230	208/230	208/230	208/230	208/230
	Phase	1	1	1	1	1	1	1
	HP	1/3	1/3	1/3	1/3	1/3	1/3	1/3
	Amps (FLA)	1.5	1.5	1.5	1.5	1.5/1.5	1.5/1.5	1.9
	Amps (LRA)	3	3	3	3	3/3	3/3	4
Evaporator Fan	No.	1	1	1	1	1	1	1
	Volts	208/230	208/230	208/230	208/230	208/230	208/230	208/230
	Phase	1	1	1	1	1	1	1
	HP	1/2	1/2	1/2	1/2	1/2	1/2	3/4
	Amps (FLA)	4.1	4.1	4.1	4.1	4.1/4.1	4.1/4.1	6



ELECTRICAL DATA – RQPM SERIES								
		-A042JK	-A048CK	-A048JK	-A049CK	-A049JK	-A060CK	-A060JK
Unit Information	Unit Operating Voltage Range	187-253	187-253	187-253	187-253	187-253	187-253	187-253
	Minimum Circuit Ampacity	36/36	26/26	36/36	26/26	36/36	32/32	43/43
	Minimum Overcurrent Protection Device Size	45/45	30/30	45/45	30/30	45/45	40/40	50/50
	Maximum Overcurrent Protection Device Size	50/50	35/35	50/50	35/35	50/50	45/45	60/60
Compressor Motor	No.	1	1	1	1	1	1	1
	Volts	208/230	208/230	208/230	208/230	208/230	208/230	208/230
	Phase	1	3	1	3	1	3	1
	HP	3.5	4	4	3450	3450	4.5	4.5
	RPM	3450	3450	3450	4	4	3450	3450
	Amps (RLA)	21.8/21.8	13.7/13.7	21.8/21.8	13.7/13.7	21.8/21.8	17.9/17.9	26.4/26.4
	Amps (LRA)	112/112	110/110	117/117	110/110	117/117	120/120	150/150
Condenser Motor	No.	1	1	1	1	1	1	1
	Volts	208/230	208/230	208/230	208/230	208/230	208/230	208/230
	Phase	1	1	1	1	1	1	1
	HP	1/3	1/3	1/3	1/3	1/3	1/3	1/3
	Amps (FLA)	1.9	1.9	1.9	1.9/1.9	1.9/1.9	1.9	1.9
	Amps (LRA)	4	4	4	4/4	4/4	4	4
Evaporator Fan	No.	1	1	1	1	1	1	1
	Volts	208/230	208/230	208/230	208/230	208/230	208/230	208/230
	Phase	1	1	1	1	1	1	1
	HP	3/4	3/4	3/4	3/4	3/4	1	1
	Amps (FLA)	6	6	6	6/6	6/6	7.6	7.6



208-240 VOLT, SINGLE PHASE, 60 HZ, AUXILIARY ELECTRIC HEATER KITS CHARACTERISTICS AND APPLICATION													
Separate Power Supply For Both Unit and Heater Kit													
Unit Model No. RQNM-	Single Power Supply For Both Unit and Heater Kit						Separate Power Supply For Both Unit and Heater Kit						
	Heater Kit			Heat Pump			Heater Kit			Heat Pump			
RXQJ- Heater Kit Nominal kW	No. of Elements	No. of Sequence Steps	Rated Heater kW @ 208-240 V	Heater KBTU/Hr @ 208-240 V	Heater Amp. @ 208-240 V	Unit Min. Ckt. Ampacity @ 208-240 V	Over Current Protective Device Size Min./Max. @ 208 V	Over Current Protective Device Size Min./Max. @ 240 V	Min. Ckt. Ampacity 208-240 V	Max. Fuse Size	Min. Circuit Ampacity 208-240 V	Over Current Protective Device Size Min./Max. @ 208 V	Over Current Protective Device Size Min./Max. @ 240 V
A024J	No Heat	—	—	—	—	20/20	25/30	25/30	20/20	—	20/20	25/30	25/30
	C05J	1	3.6/4.8	12.28/16.38	17.33/20	42/45	45/50	45/50	—	25/25	—	—	—
	C07J	1	5.4/7.2	18.42/24.56	26/30	53/58	60/60	60/60	—	35/40	—	—	—
A030J	C10J	2	7.2/9.6	24.57/32.76	34.7/40	64/70	70/70	70/70	—	45/50	—	—	—
	No Heat	—	—	—	—	21/21	25/35	25/35	21/21	—	21/21	25/35	25/35
	C05J	1	3.6/4.8	12.28/16.38	17.33/20	43/46	45/50	50/50	—	25/25	—	—	—
A036J	C07J	1	5.4/7.2	18.42/24.56	26/30	54/59	60/60	60/60	—	35/40	—	—	—
	C10J	2	7.2/9.6	24.57/32.76	34.7/40	65/71	70/70	80/80	—	45/50	—	—	—
	C15J	3	10.8/14.4	36.85/49.13	52/60	86/96	90/90	100/100	—	70/80	—	—	—
A042J	C20J	4	14.4/19.2	49.12/65.52	69.33/80	112/125	125/125	150/150	—	90/100	—	—	—
	No Heat	—	—	—	—	25/25	30/40	30/40	25/25	—	25/25	30/40	30/40
	C05J	1	3.6/4.8	12.28/16.38	17.33/20	47/50	50/50	60/60	—	25/25	—	—	—
A048J	C07J	1	5.4/7.2	18.42/24.56	26/30	58/63	60/60	70/70	—	35/40	—	—	—
	C10J	2	7.2/9.6	24.57/32.76	34.7/40	69/75	70/70	80/80	—	45/50	—	—	—
	C15J	3	10.8/14.4	36.85/49.13	52/60	90/100	90/90	0/100	—	70/80	—	—	—
A060J	C20J	4	14.4/19.2	49.12/65.52	69.33/80	112/133	125/125	150/150	—	90/100	—	—	—
	No Heat	—	—	—	—	33/33	40/50	40/50	33/33	—	33/33	40/50	40/50
	C05J	1	3.6/4.8	12.28/16.38	17.33/20	54/58	60/70	60/70	—	25/25	—	—	—
A060J	C07J	1	5.4/7.2	18.42/24.56	26/30	65/70	70/70	70/80	—	35/40	—	—	—
	C10J	2	7.2/9.6	24.57/32.76	34.7/40	76/83	80/80	90/90	—	45/50	—	—	—
	C15J	3	10.8/14.4	36.85/49.13	52/60	98/108	100/100	110/110	—	70/80	—	—	—
A060J	C20J	4	14.4/19.2	49.12/65.52	69.33/80	120/133	125/125	150/150	—	90/100	—	—	—
	No Heat	—	—	—	—	41/41	50/60	50/60	41/41	—	41/41	50/60	50/60
	C05J	1	3.6/4.8	12.28/16.38	17.33/20	63/66	80/80	80/80	—	25/25	—	—	—
A060J	C07J	1	5.4/7.2	18.42/24.56	26/30	74/79	90/90	90/90	—	35/40	—	—	—
	C10J	2	7.2/9.6	24.57/32.76	34.7/40	85/91	90/100	100/100	—	45/50	—	—	—
	C15J	3	10.8/14.4	36.85/49.13	52/60	106/116	110/110	125/125	—	70/80	—	—	—
A060J	C20J	4	14.4/19.2	49.12/65.52	69.33/80	128/141	150/150	150/150	—	90/100	—	—	—



208-240 VOLT, THREE PHASE, 60 HZ, AUXILIARY ELECTRIC HEATER KITS CHARACTERISTICS AND APPLICATION															
Single Power Supply For Both Unit and Heater Kit															
Unit Model No. RQNM-	Heater Kit						Heat Pump						Separate Power Supply For Both Unit and Heater Kit		
	RXQJ-Heater Kit Nominal kW	No. of Elements	No. of Sequence Steps	Rated Heater kW @ 208-240 V	Heater KBTU/Hr @ 208-240 V	Heater Amp. @ 208-240 V	Unit Min. Ckt. Ampacity @ 208-240 V	Over Current Protective Device Size Min./Max. @ 208 V	Min./Max. @ 240 V	Min. Ckt. Ampacity	Max. Fuse Size	Min. Circuit Ampacity 208-240 V	Heat Pump		
												Min./Max. @ 208 V	Over Current Protective Device Size Min./Max. @ 240 V	Min./Max. @ 208 V	
A036C	No Heat	—	—	—	—	—	17/17	20/25	20/25	—	—	17/17	20/25	20/25	
	C10C	2	1	7.2/9.6	24.57/32.76	20/23.1	42/46	45/45	50/50	25/29	25/30	—	—	—	
	C15C	3	2	10.8/14.4	36.85/49.13	30.1/34.7	55/61	60/60	70/70	38/44	40/45	—	—	—	
A042C	No Heat	—	—	—	—	—	23/23	30/35	30/35	—	—	23/23	30/35	30/35	
	C10C	2	1	7.2/9.6	24.57/32.76	20/23.1	48/52	50/50	60/60	25/29	25/30	—	—	—	
	C15C	3	2	10.8/14.4	36.85/49.13	30.1/34.7	61/66	70/70	70/70	38/44	40/45	—	—	—	
	C20C	4	2	14.4/19.2	49.12/65.52	40/46.3	73/81	80/80	90/90	50/58	50/60	—	—	—	
A048C	No Heat	—	—	—	—	—	23/23	30/35	30/35	—	—	23/23	30/35	30/35	
	C10C	2	1	7.2/9.6	24.57/32.76	20/23.1	48/52	50/50	60/60	25/29	25/30	—	—	—	
	C15C	3	2	10.8/14.4	36.85/49.13	30.1/34.7	60/66	60/60	70/70	38/44	40/45	—	—	—	
	C20C	4	2	14.4/19.2	49.12/65.52	40/46.3	73/81	80/80	90/90	50/58	50/60	—	—	—	
A060C	No Heat	—	—	—	—	—	31/31	35/45	35/45	—	—	31/31	35/45	35/45	
	C10C	2	1	7.2/9.6	24.57/32.76	20/23.1	56/59	60/60	60/70	25/29	25/30	—	—	—	
	C15C	3	2	10.8/14.4	36.85/49.13	30.1/34.7	69/74	70/70	80/80	38/44	40/45	—	—	—	
	C20C	4	2	14.4/19.2	49.12/65.52	40/46.3	81/88	90/90	90/90	50/58	50/60	—	—	—	



208-240 VOLT, SINGLE PHASE, 60 HZ, AUXILIARY ELECTRIC HEATER KITS CHARACTERISTICS AND APPLICATION													
Separate Power Supply For Both Unit and Heater Kit													
Unit Model No. RQPM-	Single Power Supply For Both Unit and Heater Kit						Separate Power Supply For Both Unit and Heater Kit						
	Heater Kit			Heat Pump			Heater Kit			Heat Pump			
RXQJ- Heater Kit Nominal kW	No. of Elements	No. of Sequence Steps	Rated Heater kW @ 208-240 V	Heater KBTU/Hr @ 208-240 V	Heater Amp. @ 208-240 V	Unit Min. Ckt. Ampacity @ 208-240 V	Over Current Protective Device Size Min./Max. @ 208 V	Over Current Protective Device Size Min./Max. @ 240 V	Min. Ckt. Ampacity 208-240 V	Max. Fuse Size	Min. Circuit Ampacity 208-240 V	Over Current Protective Device Size Min./Max. @ 208 V	Over Current Protective Device Size Min./Max. @ 240 V
A024J	No Heat	—	—	—	—	23/23	30/35	30/35	—	—	23/23	30/35	30/35
	C05J	1	3.6/4.8	12.28/16.38	17.33/20	45/48	45/50	50/50	22/25	25/25	—	—	—
	C07J	1	5.4/7.2	18.42/24.56	26/30	55/60	60/60	60/60	33/38	35/40	—	—	—
A030J	C10J	2	7.2/9.6	24.57/32.76	34.7/40	66/73	70/70	80/80	44/50	45/50	—	—	—
	No Heat	—	—	—	—	24/24	30/35	30/35	—	—	24/24	30/35	30/35
	C05J	1	3.6/4.8	12.28/16.38	17.33/20	45/49	45/50	50/50	22/25	25/25	—	—	—
A036J	C07J	1	5.4/7.2	18.42/24.56	26/30	56/61	60/60	70/70	33/38	35/40	—	—	—
	C10J	2	7.2/9.6	24.57/32.76	34.7/40	67/74	70/70	80/80	44/50	45/50	—	—	—
	C15J	3	10.8/14.4	36.85/49.13	52/60	89/99	90/90	100/100	65/75	70/80	—	—	—
A037J	C20J	4	14.4/19.2	49.12/65.52	69.33/80	114/127	125/125	150/150	87/100	90/100	—	—	—
	No Heat	—	—	—	—	27/27	35/40	35/40	—	—	27/27	35/40	35/40
	C05J	1	3.6/4.8	12.28/16.38	17.33/20	49/52	50/60	60/60	22/25	25/25	—	—	—
A042J	C07J	1	5.4/7.2	18.42/24.56	26/30	59/64	60/60	70/70	33/38	35/40	—	—	—
	C10J	2	7.2/9.6	24.57/32.76	34.7/40	70/77	70/70	80/80	44/50	45/50	—	—	—
	C15J	3	10.8/14.4	36.85/49.13	52/60	92/102	100/100	110/110	65/75	70/80	—	—	—
A048J	C20J	4	14.4/19.2	49.12/65.52	69.33/80	112/136	125/125	150/150	87/100	90/100	—	—	—
	No Heat	—	—	—	—	36/36	45/50	45/50	—	—	36/36	45/50	45/50
	C05J	1	3.6/4.8	12.28/16.38	17.33/20	47/61	60/70	70/70	22/25	25/25	—	—	—
A049J	C07J	1	5.4/7.2	18.42/24.56	26/30	68/73	70/80	80/80	33/38	35/40	—	—	—
	C10J	2	7.2/9.6	24.57/32.76	34.7/40	79/86	80/90	90/90	44/50	45/50	—	—	—
	C15J	3	10.8/14.4	36.85/49.13	52/60	101/111	110/110	125/125	65/75	70/80	—	—	—
A060J	C20J	4	14.4/19.2	49.12/65.52	69.33/80	122/136	125/125	150/150	87/100	90/100	—	—	—
	No Heat	—	—	—	—	43/43	50/60	50/60	—	—	43/43	50/60	50/60
	C05J	1	3.6/4.8	12.28/16.38	17.33/20	65/68	80/80	80/80	22/25	25/25	—	—	—
A060J	C07J	1	5.4/7.2	18.42/24.56	26/30	75/80	90/90	90/90	33/38	35/40	—	—	—
	C10J	2	7.2/9.6	24.57/32.76	34.7/40	86/93	90/100	100/100	44/50	45/50	—	—	—
	C15J	3	10.8/14.4	36.85/49.13	52/60	108/118	110/110	125/125	65/75	70/80	—	—	—
A060J	C20J	4	14.4/19.2	49.12/65.52	69.33/80	130/143	150/150	150/150	87/100	90/100	—	—	—



208-240 VOLT, THREE PHASE, 60 HZ, AUXILIARY ELECTRIC HEATER KITS CHARACTERISTICS AND APPLICATION																
Single Power Supply For Both Unit and Heater Kit																
Unit Model No. RQPM-	Heater Kit						Heat Pump						Separate Power Supply For Both Unit and Heater Kit			
	RXQJ-Heater Kit Nominal kW	No. of Elements	No. of Sequence Steps	Rated Heater kW @ 208-240 V	Heater KBTU/Hr @ 208-240 V	Heater Amp. @ 208-240 V	Unit Min. Ckt. Ampacity @ 208-240 V	Over Current Protective Device Size Min./Max. @ 208 V	Min./Max. @ 240 V	Min. Ckt. Ampacity	Max. Fuse Size	Min. Circuit Ampacity 208-240 V	Heat Pump			
												Min./Max. @ 208 V	Min./Max. @ 240 V	Min./Max. @ 208 V	Over Current Protective Device Size Min./Max. @ 240 V	
A036C A037C	No Heat	—	—	—	—	—	19/19	25/25	25/25	—	—	19/19	25/25	25/25	25/25	
	C10C	2	1	7.2/9.6	24.57/32.76	20/23.1	44/48	45/45	50/50	25/29	25/30	—	—	—	—	
	C15C	3	2	10.8/14.4	36.85/49.13	30.1/34.7	57/61	60/60	70/70	38/44	40/45	—	—	—	—	
A042C	No Heat	—	—	—	—	—	26/26	30/35	30/35	—	—	26/26	30/35	30/35	30/35	
	C10C	2	1	7.2/9.6	24.57/32.76	20/23.1	51/55	60/60	60/60	25/29	25/30	—	—	—	—	
	C15C	3	2	10.8/14.4	36.85/49.13	30.1/34.7	64/69	70/70	70/70	38/44	40/45	—	—	—	—	
	C20C	4	2	14.4/19.2	49.12/65.52	40/46.3	76/84	80/80	90/90	50/58	50/60	—	—	—	—	
A048C A049C	No Heat	—	—	—	—	—	26/26	30/35	30/35	—	—	26/26	30/35	30/35	30/35	
	C10C	2	1	7.2/9.6	24.57/32.76	20/23.1	51/54	60/60	60/60	25/29	25/30	—	—	—	—	
	C15C	3	2	10.8/14.4	36.85/49.13	30.1/34.7	63/69	70/70	70/70	38/44	40/45	—	—	—	—	
	C20C	4	2	14.4/19.2	49.12/65.52	40/46.3	76/83	80/80	90/90	50/58	50/60	—	—	—	—	
A060C	No Heat	—	—	—	—	—	32/32	40/45	40/45	—	—	32/32	40/45	40/45	40/45	
	C10C	2	1	7.2/9.6	24.57/32.76	20/23.1	57/61	60/60	70/70	25/29	25/30	—	—	—	—	
	C15C	3	2	10.8/14.4	36.85/49.13	30.1/34.7	69/76	70/70	80/80	38/44	40/45	—	—	—	—	
	C20C	4	2	14.4/19.2	49.12/65.52	40/46.3	82/90	90/90	90/90	50/58	50/60	—	—	—	—	



UNIT DIMENSIONS—RQNM/RQPM- SERIES

DIMENSIONS

Model	Height "A"
024, 030, 036, 037	29 1/8"
042, 048, 049, 060	37 1/8"

FRONT VIEW

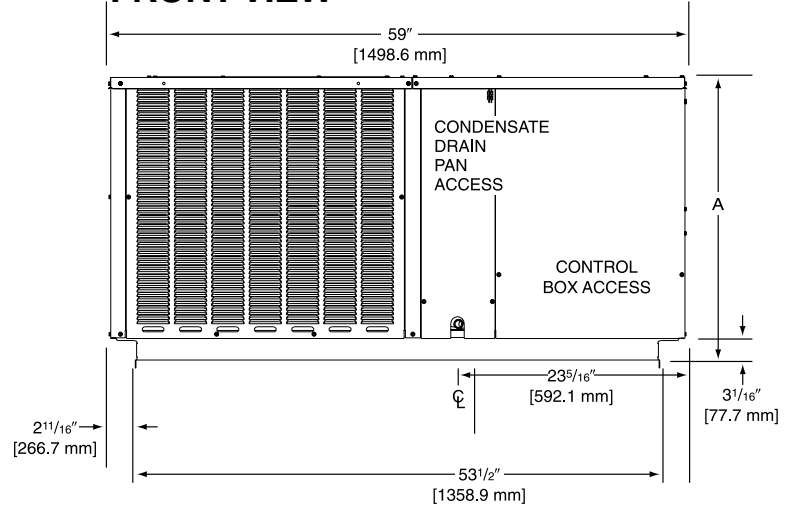

REAR VIEW

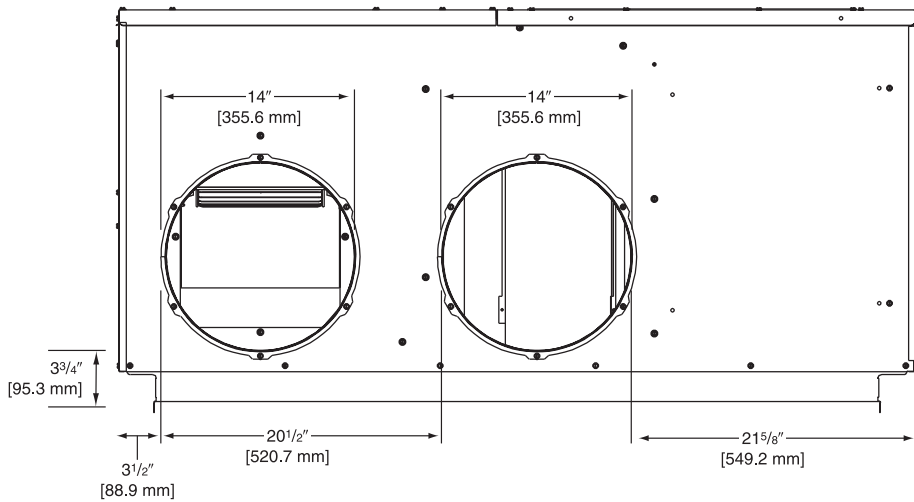

ELECTRICAL CONNECTIONS

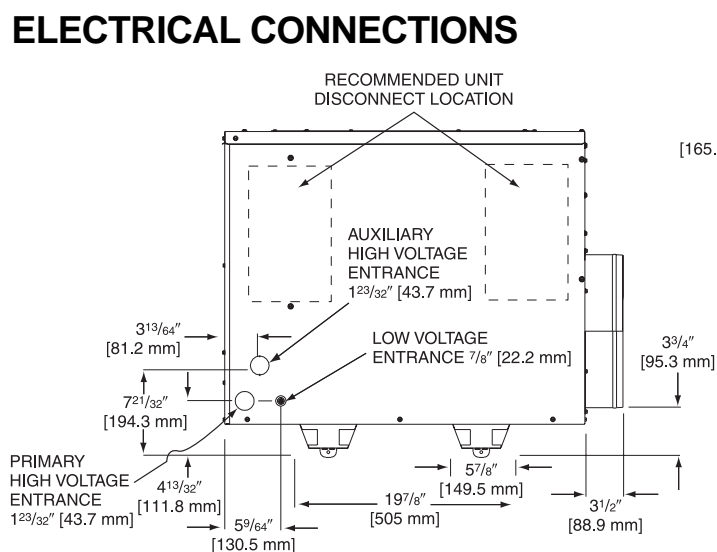

BOTTOM VIEW

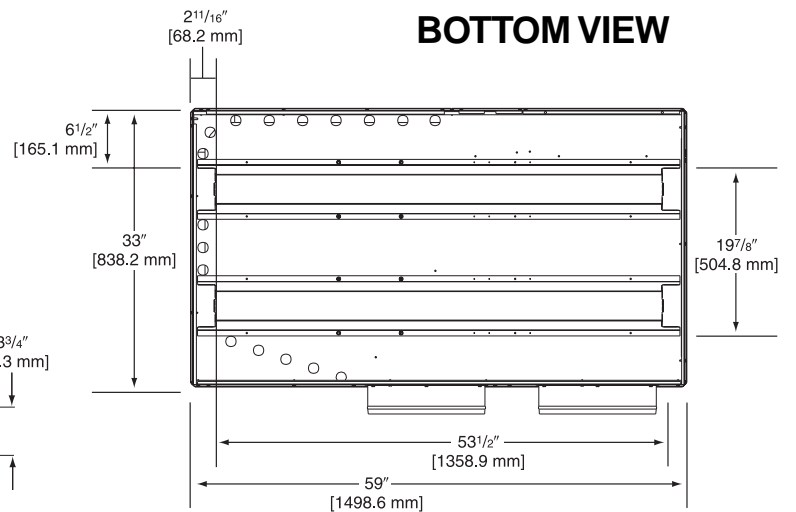

[] Designates Metric Conversions

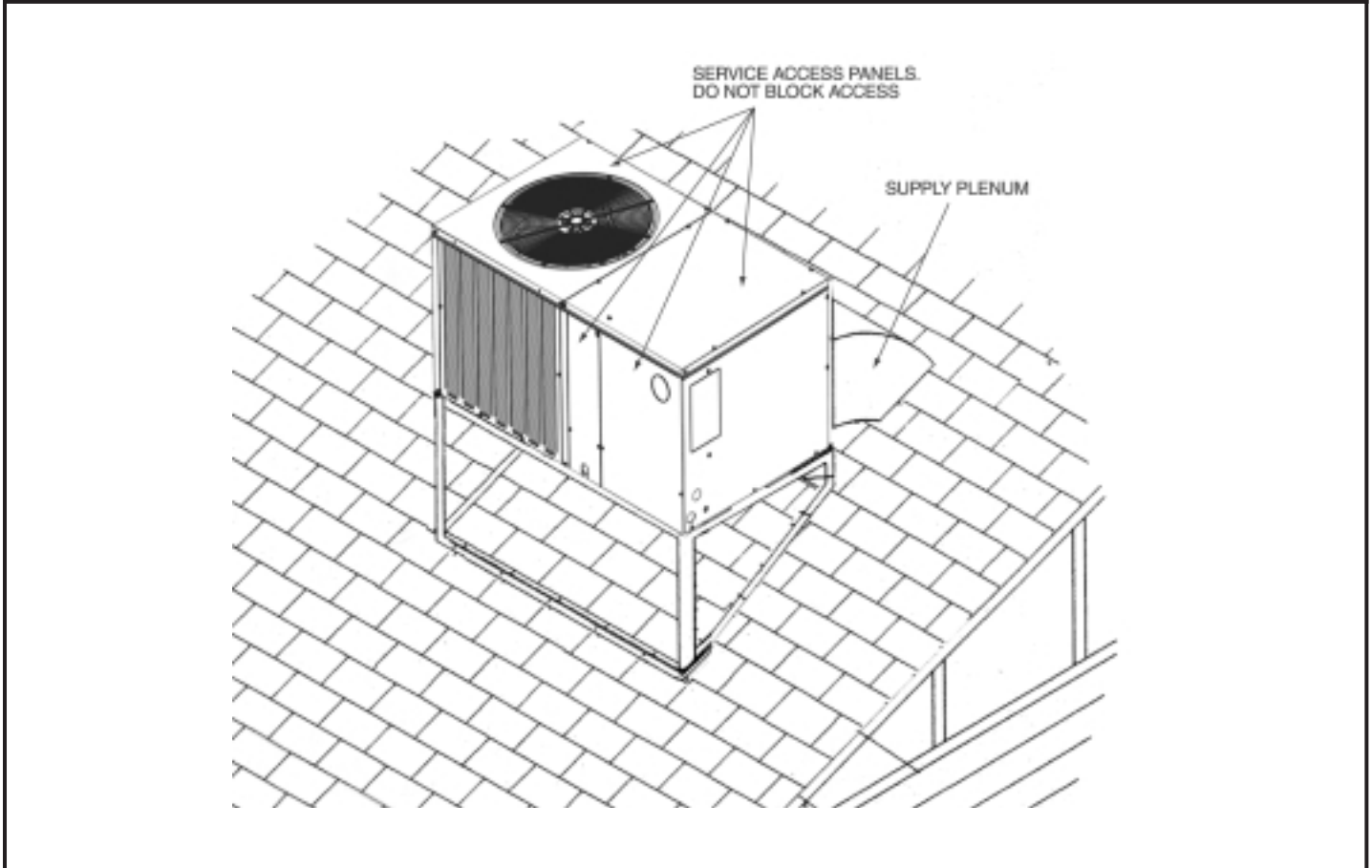
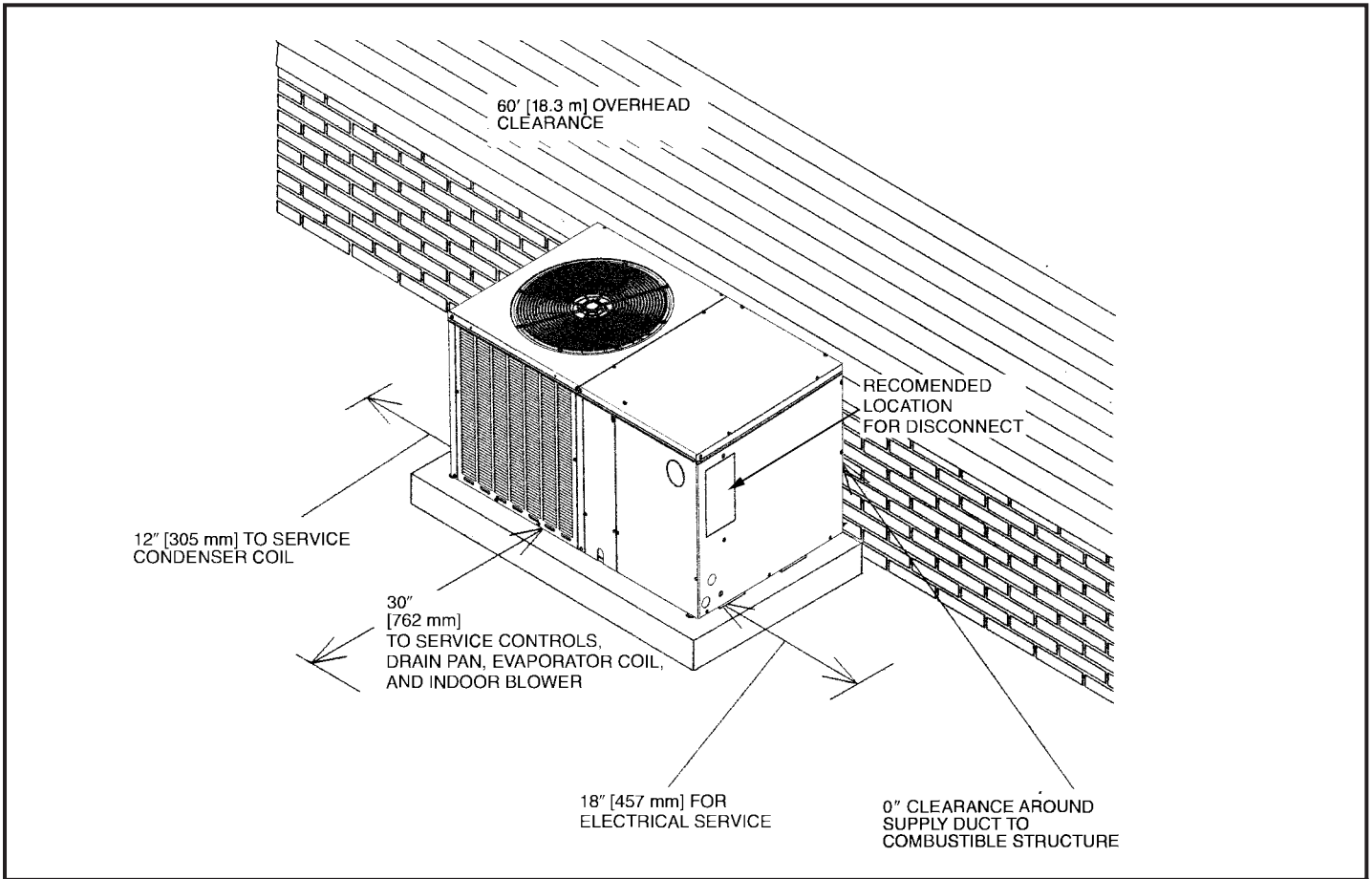

ACCESSORY EQUIPMENT

Accessory Description	Model Application	Accessory Model No.
Outdoor Thermostat	RQNM/RQPM	RXPT-A01
Thermostats	RQNM/RQPM	See Thermostat Specification Sheet (T11-001)

THERMOSTATS

■ Thermostats



100-Series *
Non-Programmable



200-Series *
Programmable



300-Series *
Deluxe
Programmable



400-Series *
Special Applications/
Programmable

500-Series *
Communicating/
Programmable

Brand	Unique Model Number Prefix	Descriptor (3 Characters)	Series (3 Characters)	System (2 Characters)	Type (2 Characters)
RHC	-	TST	101	GE	MS
RHC=Rheem		TST=Thermostat	100=Non-Programmable 200=Programmable 300=Deluxe Programmable 400=Special Applications/ Programmable 500=Communicating/ Programmable	GE=Gas/Oil/Electric HP=Heat Pump MD=Modulating Furnace DF=Dual Fuel UN=Universal AC/HP/GE CM=Communicating	SS=Single-Stage MS=Multi-Stage

* Photos are representative. Actual models may vary.

For detailed thermostat match-up information, see specification sheet form number T11-001.

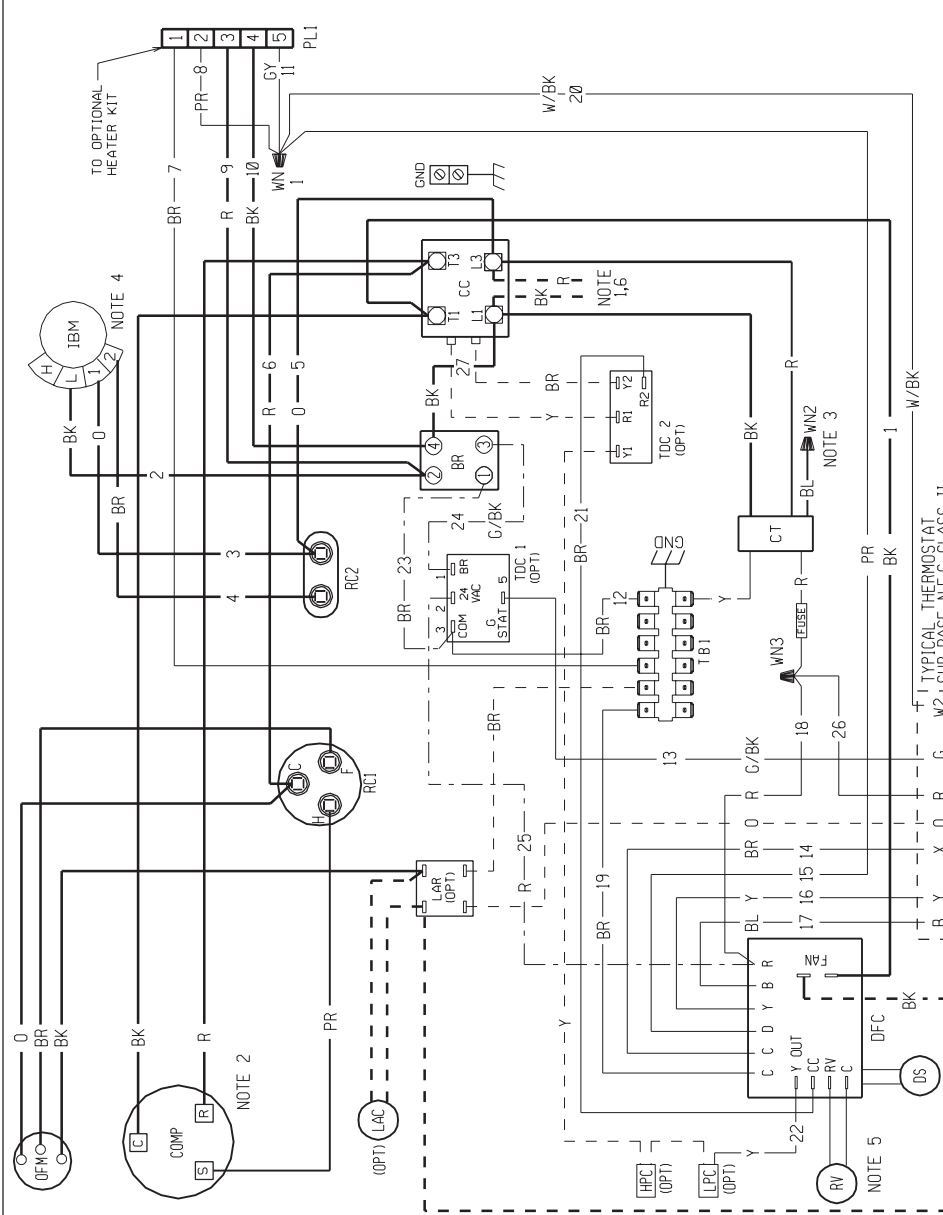
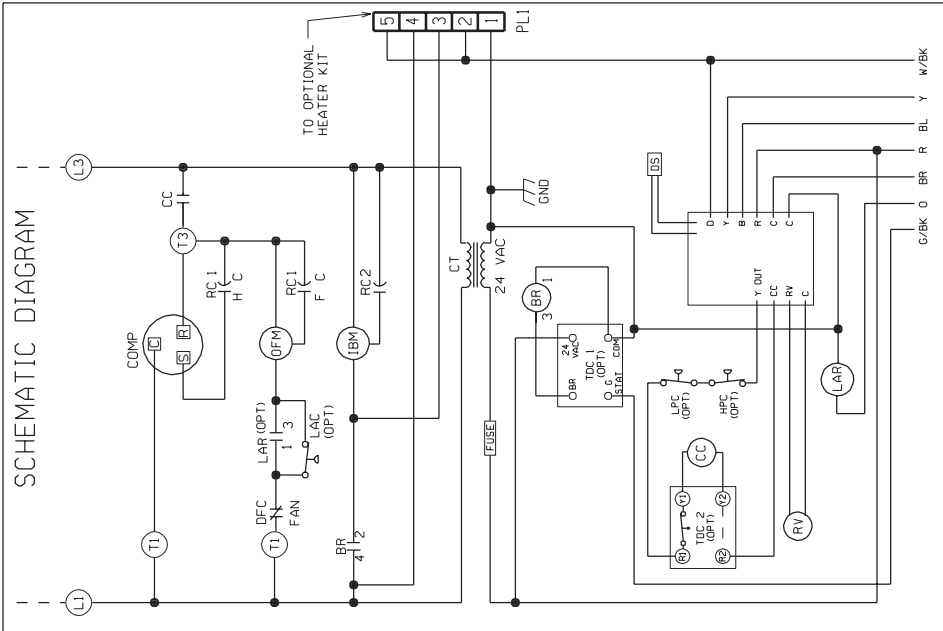

WIRE COLOR CODE

BK	_BLACK	GY	_GRAY	R	_RED
BR	_BROWN	O	_ORANGE	W	_WHITE
BL	_BLUE	PK	_PINK	Y	_YELLOW
G	_GREEN	PR	_PURPLE		

ELECTRICAL WIRING DIAGRAM

PACKAGE HEAT PUMP

1 PH, 208/230 VOLT - 60 HZ

DR. BY DATE
APP. BY DATE
BJL 02-10-04

REV 05
DWG. NO. 90-23621-08

WIRING INFORMATION

LINE VOLTAGE
-FACTORY STANDARD
-FACTORY OPTION
-FIELD INSTALLED

LOW VOLTAGE
-FACTORY STANDARD
-FACTORY OPTION
-FIELD INSTALLED

REPLACEMENT WIRE
-MUST BE THE SAME SIZE AND TYPE OF INSULATION AS ORIGINAL (105 C° MIN.)
WARNING
-CABINET MUST BE PERMANENTLY GROUNDED AND CONFORM TO I.E.C., N.E.C., C.E.C. AND LOCAL CODES AS APPLICABLE.

NOTES:

- CONNECTORS SUITABLE FOR USE WITH COPPER CONDUCTORS ONLY.
- COMPRESSOR MOTOR THERMALLY PROTECTED.
- TRANSFORMER FACTORY WIRED FOR 230 VOLTS. USE RED AND BLUE LEADS FOR 208 VOLTS.
- MOTOR FACTORY WIRED FOR LOW SPEED. SEE AIRFLOW TABLES IN INSTALLATION INSTRUCTIONS TO DETERMINE CORRECT SPEED FOR UNIT APPLICATION.
- THIS COMPONENT ENERGIZED IN HEATING.
- FIELD WIRING OR CONNECTION FROM HEATER KIT FUSE BLOCK.

COMPONENT CODE

LAC	LOW AMBIENT COOLING CONTROL
ALC	AUX. LIMIT CONTROL
BR	BLOWER RELAY
CC	COMPRESSOR CONTACTOR
CH	CRANKCASE HEATER
COMP	COMPRESSOR
CT	CONTROL TRANSFORMER
DFC	DEFROST CONTROL
DR	DEFROST RELAY
IB	DEFROST SENSOR
GND	GROUNDING
HPC	HIGH PRESSURE CONTROL
IBM	INDOOR BLOWER MOTOR
LAR (OPT)	LOW AMBIENT RELAY
OFM (OPT)	OUTDOOR FAN MOTOR
OPT	OPTIONAL
PL	PLUG
RC	RUN CAPACITOR
RCV	REVERSING VALVE
TRM	TERMINAL BLOCK
Y	WIRE DELAY CONTROL WIRE NUT

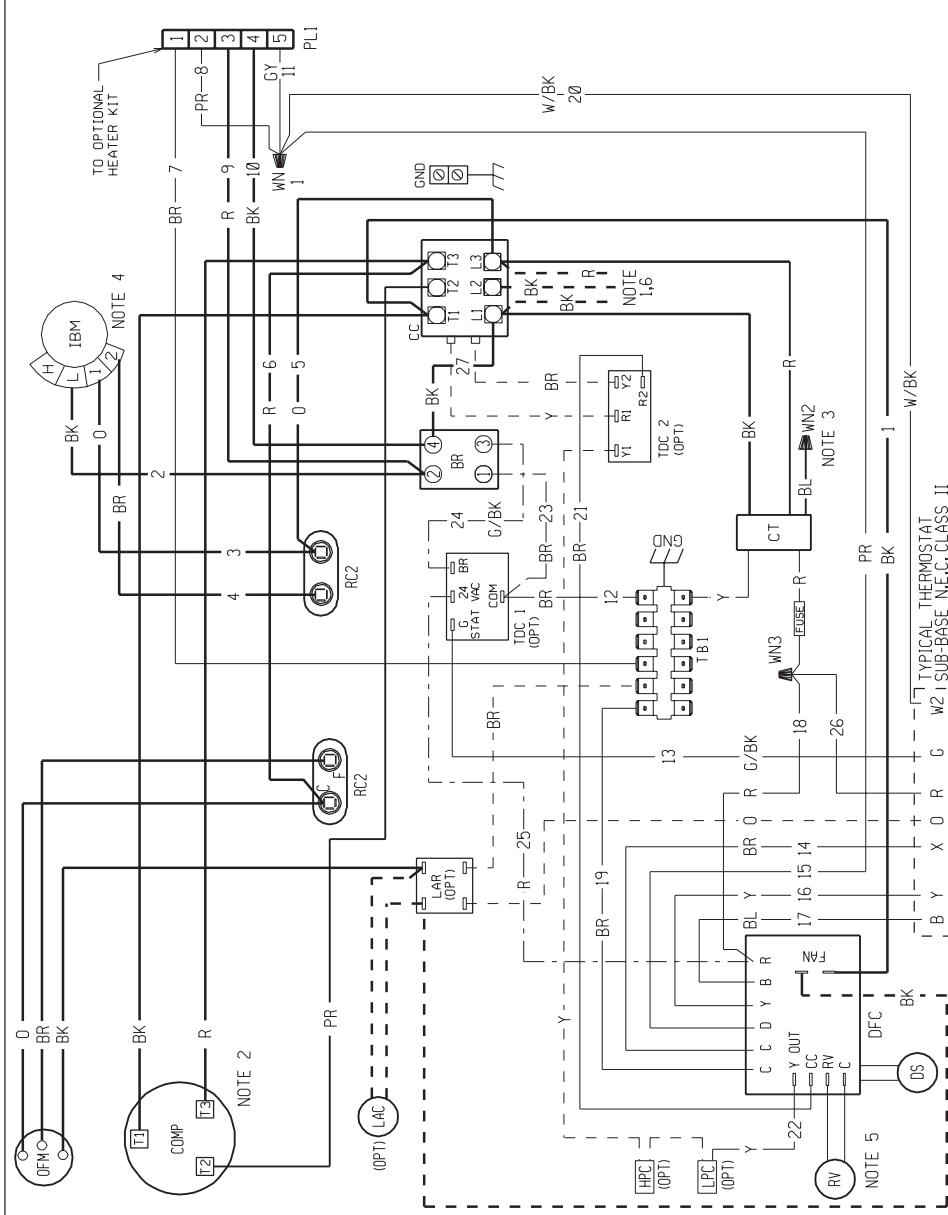
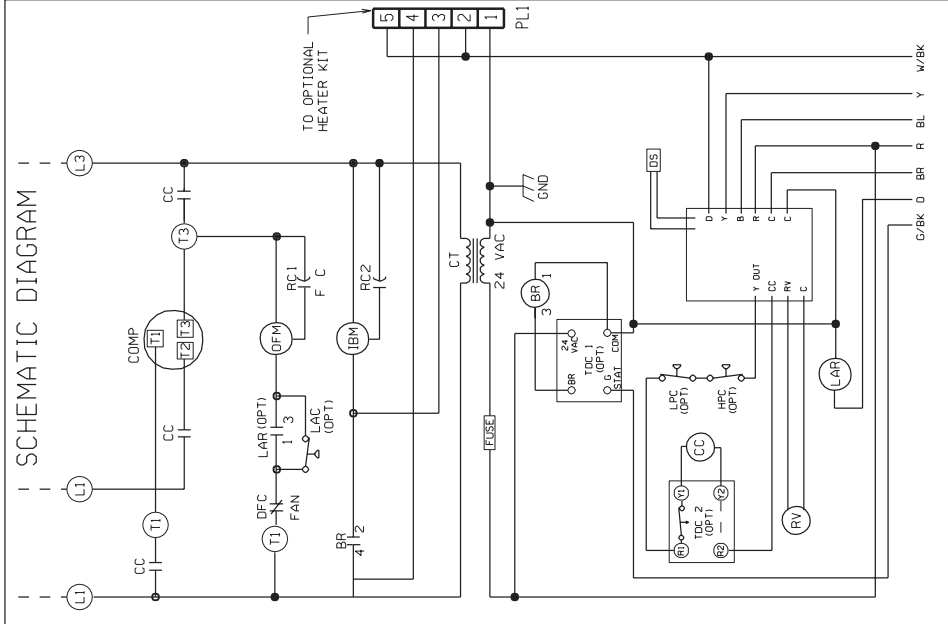

WIRE COLOR CODE	
BK	BLACK
BR	BROWN
BL	BLUE
G	GREEN
W	WHITE
Y	GRAY
O	ORANGE
PR	PURPLE
R	RED
W	WHITE
Y	GRAY

WIRING INFORMATION	
---	LINE VOLTAGE
---	-FACTORY STANDARD
---	-FACTORY OPTION
---	-FIELD INSTALLED
---	LOW VOLTAGE
---	-FACTORY STANDARD
---	-FACTORY OPTION
---	-FIELD INSTALLED
REPLACEMENT WIRE	
-MUST BE THE SAME SIZE AND TYPE OF INSULATION AS ORIGINAL (105 C MIN.)	
WARNING	
-CABINET MUST BE PERMANENTLY GROUNDED AND CONFORM TO I.E.C., N.E.C., C.E.C. AND LOCAL CODES AS APPLICABLE.	

NOTES:	
1.	CONNECTORS SUITABLE FOR USE WITH COPPER CONDUCTORS ONLY.
2.	COMPRESSOR MOTOR THERMALLY PROTECTED.
3.	TRANSFORMER FACTORY WIRED FOR 230 VOLTS. USE RED AND BLUE LEADS FOR 208 VOLTS.
4.	MOTOR FACTORY WIRED FOR LOW SPEED. SEE AIRFLOW TABLES IN INSTALLATION INSTRUCTIONS TO DETERMINE CORRECT SPEED FOR UNIT APPLICATION.
5.	THIS COMPONENT ENERGIZED IN HEATING.
6.	FIELD WIRING OR CONNECTION FROM HEATER KIT FUSE BLOCK.

COMPONENT CODE	
ALC	AUX. LIMIT CONTROL
BR	BLOWER RELAY CONTACTOR
CC	COMPRESSOR HEATER
CC	COMPRESSOR MOTOR
COMP	OPTIONAL
CT	CONTROL TRANSFORMER
DFC	DEFROST CONTROL
DR	DEFROST SENSOR
DS	GROUND
G	GROUND
HGS	HOT GAS SENSOR
HPC	HIGH PRESSURE CONTROL
IBM	INDOOR BLOWER MOTOR
LAC	LOW AMBIENT COOLING
LAR	CONTROL RELAY
LFM	OUTDOOR FAN MOTOR
OPT	OPTIONAL
PL1	PLUG
RC	RUN CAPACITOR
RV	REVERSING VALVE
TB	TERMINAL BLOCK
TDC	TIME DELAY CONTROL
W	WIRE NUT

DWG. NO.	90-23621-10
REV	01



SCHEMATIC DIAGRAM

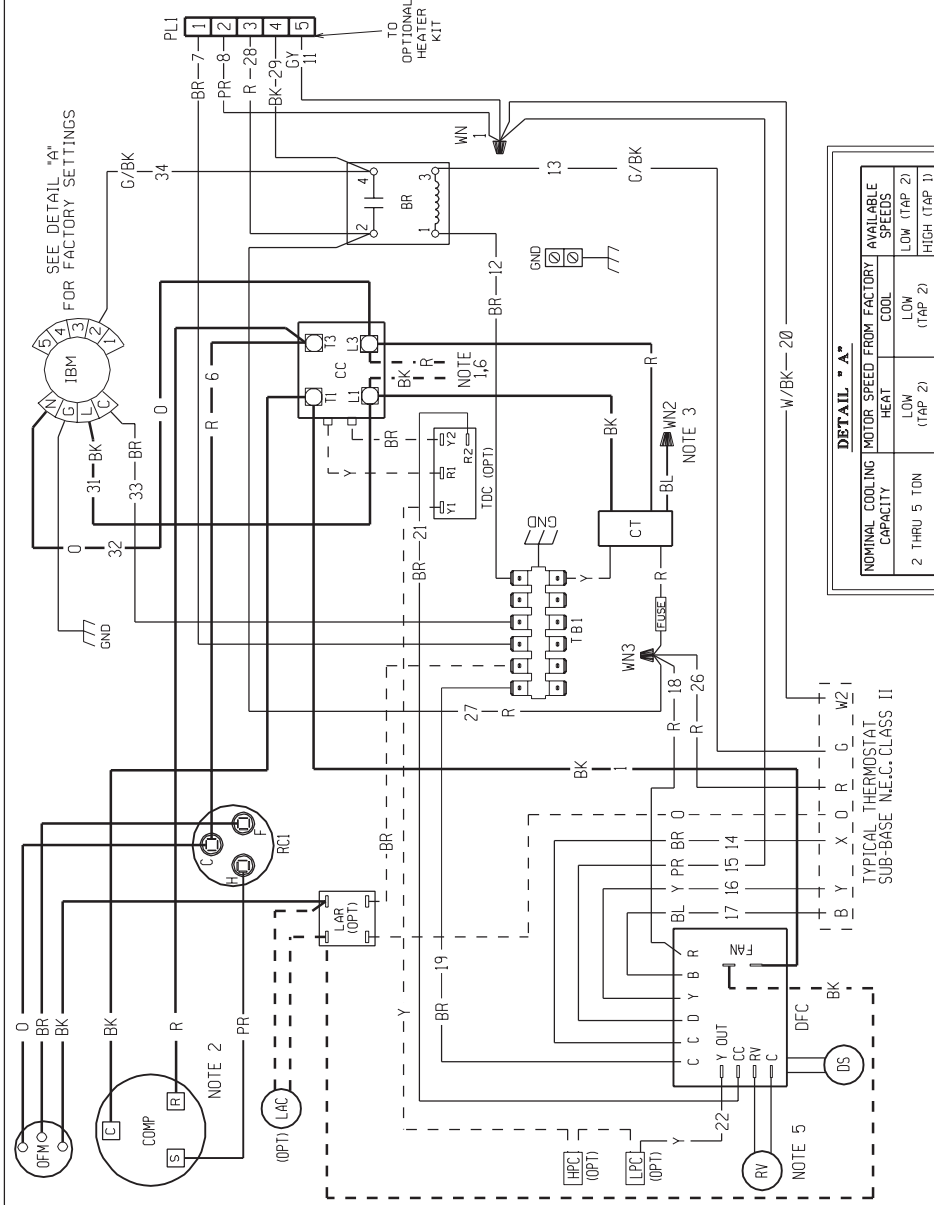
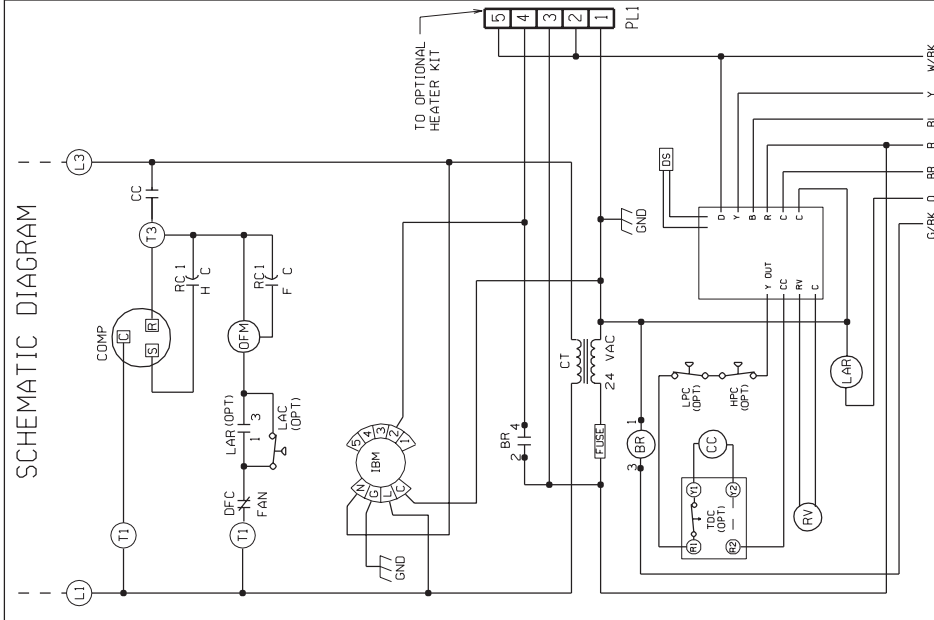

WIRE COLOR CODE

BK	BLACK	GY	GRAY	R	RED
BR	BROWN	O	ORANGE	W	WHITE
BL	BLUE	PK	PINK	Y	YELLOW
G	GREEN	PR	PURPLE		

ELECTRICAL WIRING DIAGRAM

PACKAGE HEAT PUMP

1 PH, 208/230 VOLT - 60 HZ

DR. BY: APP. BY: DATE: DWG. NO. REV: 01

JRJ 7-13-05 90-23621-16

WIRING INFORMATION

LINE VOLTAGE
 -FACTORY STANDARD
 -FACTORY OPTION
 -FIELD INSTALLED

LOW VOLTAGE
 -FACTORY STANDARD
 -FACTORY OPTION
 -FIELD INSTALLED

REPLACEMENT WIRE
 -MUST BE THE SAME SIZE AND TYPE OF INSULATION AS ORIGINAL (105 C MIN.)
 WARNING
 -CABINET MUST BE PERMANENTLY GROUNDED AND CONFORM TO I.E.C., N.E.C., C.E.C. AND LOCAL CODES AS APPLICABLE.

NOTES:

- CONNECTORS SUITABLE FOR USE WITH COPPER CONDUCTORS ONLY.
- COMPRESSOR MOTOR THERMALLY PROTECTED.
- TRANSFORMER FACTORY WIRE FOR 230 VOLTS. USE RED AND BLUE LEADS FOR 208 VOLTS.
- MOTOR FACTORY WIRE FOR LOW SPEED. SEE AIRFLOW TABLES IN INSTALLATION INSTRUCTIONS TO DETERMINE CORRECT SPEED FOR UNIT APPLICATION.
- THIS COMPONENT ENERGIZED IN HEATING.
- FIELD WIRING OR CONNECTION FROM HEATER KIT FUSE BLOCK.

COMPONENT CODE

ALC	AUX. LIMIT CONTROL
BLR	BLOWER RELAY
CC	COMPRESSOR CONTACTOR
CCH	CRANKCASE HEATER
COMP	COMPRESSOR
CT	CONTROL TRANSFORMER
DFC	DEFROST CONTROL
DR	DEFROST RELAY
GS	GROUND SENSING VALVE
GR	GROUND
HPS	HOT GAS SENSOR
HPC	HIGH PRESSURE CONTROL
IBM	INDOOR BLOWER MOTOR

DETAIL "A"

NOMINAL COOLING CAPACITY	MOTOR SPEED FROM FACTORY	AVAILABLE SPEEDS
2 THRU 5 TON	HEAT LOW (TAP 2)	LOW (TAP 2)
	COOL LOW (TAP 2)	HIGH (TAP 1)

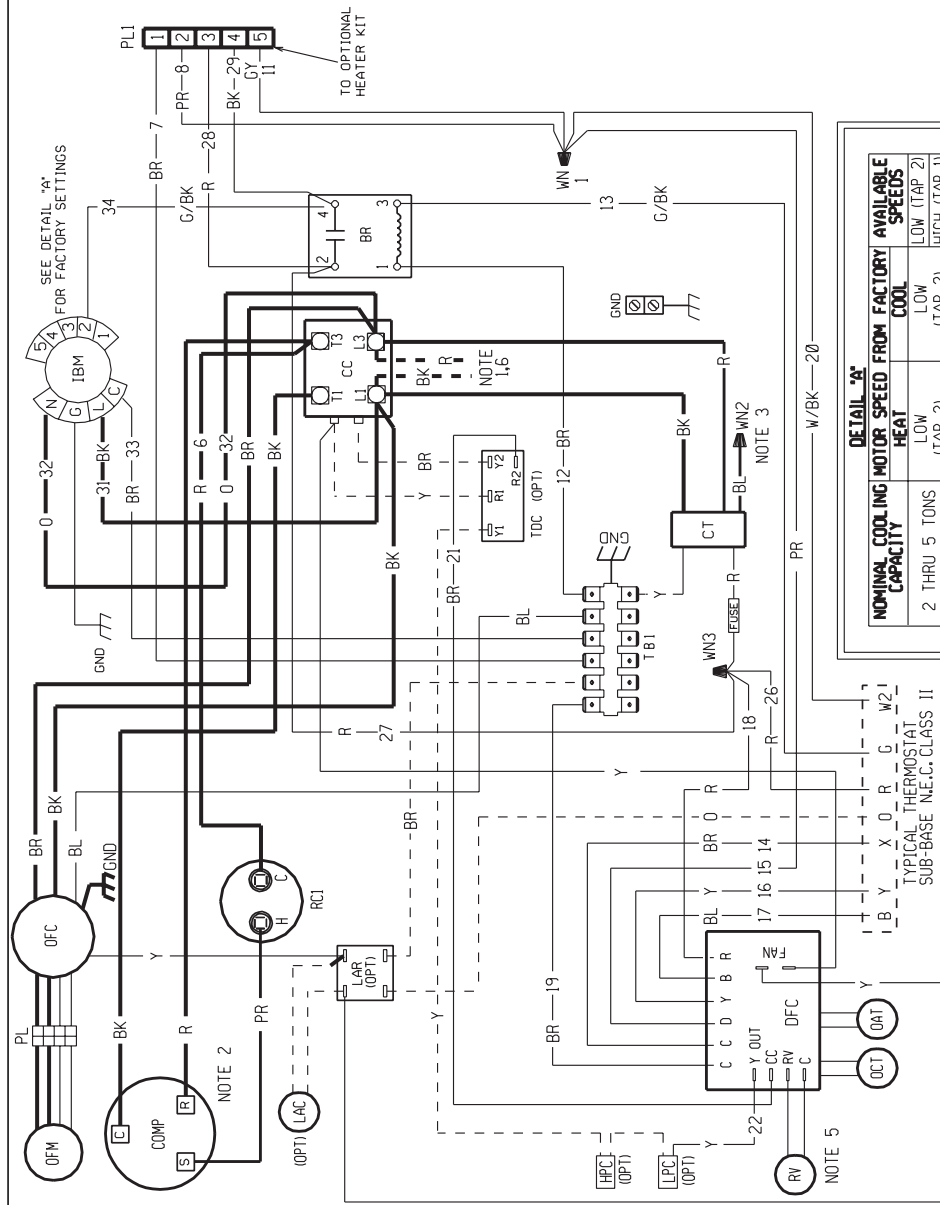
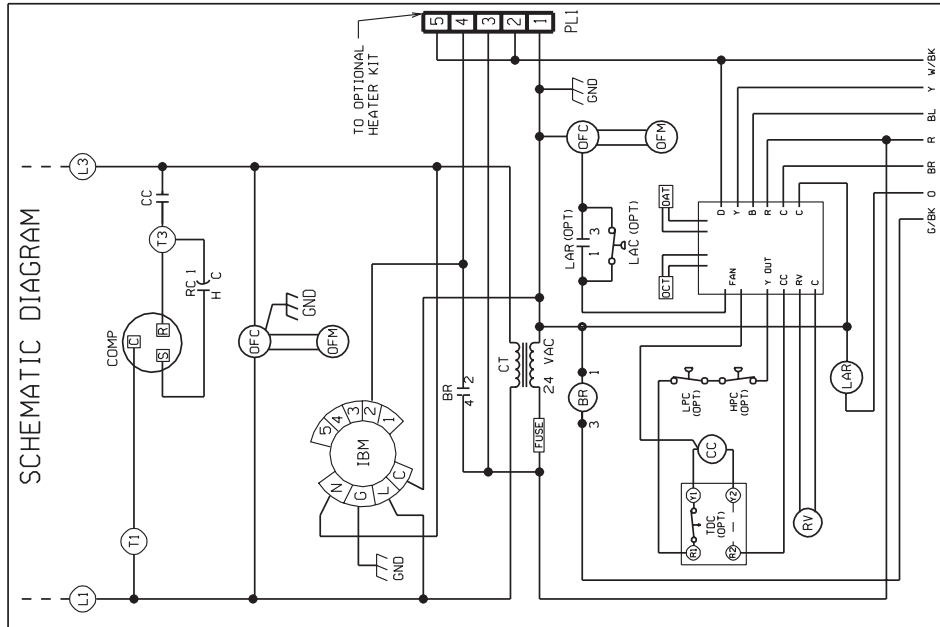

WIRE COLOR CODE

BK	BLACK	GY	GRAY	R	RED
BR	BROWN	O	ORANGE	W	WHITE
BL	BLUE	PK	PINK	Y	YELLOW
G	GREEN	PR	PURPLE	CL	CLEAR

ELECTRICAL WIRING DIAGRAM PACKAGE HEAT PUMP WITH INDOOR X-MOTOR AND OUTDOOR REMOTE CONTROL ECM
 1 PH., 208/230 VOLT - 60 HZ

DR. BY: [] DATE: [] DWG. NO.: **90-23621-22** REV: **02**
 MGR: [] APP. BY: [] 8-6-09

WIRING INFORMATION

- LINE VOLTAGE
- FACTORY STANDARD
- FACTORY OPTION
- FIELD INSTALLED
- LOW VOLTAGE
- FACTORY STANDARD
- FACTORY OPTION
- FIELD INSTALLED

REPLACEMENT WIRE MUST BE THE SAME SIZE AND TYPE OF INSULATION AS ORIGINAL (105 C MIN.).

WARNING
 - CABINET MUST BE PERMANENTLY GROUNDED AND CONFORM TO I.E.C., N.E.C., C.E.C. AND LOCAL CODES AS APPLICABLE.

NOTES:

- CONNECTORS SUITABLE FOR USE WITH COPPER CONDUCTORS ONLY.
- COMPRESSOR MOTOR THERMALLY PROTECTED.
- TRANSFORMER FACTORY WIRE FOR 230 VOLTS. USE RED AND BLUE LEADS FOR 208 VOLTS.
- MOTOR FACTORY WIRE FOR LOW SPEED. SEE AIRFLOW TABLES IN INSTALLATION INSTRUCTIONS TO DETERMINE CORRECT SPEED FOR UNIT APPLICATION.
- THIS COMPONENT ENERGIZED IN HEATING.
- FIELD WIRING OR CONNECTION FROM HEATER KIT FUSE BLOCK.

NOMINAL COOLING CAPACITY	MOTOR SPEED FROM FACTORY		AVAILABLE SPEEDS	
	HEAT	COOL	LOW (TAP 2)	HIGH (TAP 1)
2 THRU 5 TONS	LOW (TAP 2)	LOW (TAP 2)	LOW (TAP 2)	HIGH (TAP 1)

COMPONENT CODE

ALC	AUX. LIMIT CONTROL	LAC	LOW AMBIENT COOLING
BR	BLOWER RELAY CONTACTOR	LAR	LOW AMBIENT RELAY
CC	CRANKCASE HEATER	OAT	OUTDOOR AMBIENT TEMP
CH	COMPRESSOR	OCT	OUTDOOR COIL TEMP
CT	CONTROL TRANSFORMER	OFM	OUTDOOR FAN MOTOR
DFC	DEFROST CONTROL	OPT	OPTIONAL PLUG
DS	DEFROST SENSOR	PL	PLUG
GND	GROUND	RC	RUN CAPACITOR
HGS	HOT GAS SENSOR	RV	REVERSING VALVE
HPC	HIGH PRESSURE CONTROL	TB	TERMINAL BLOCK
IBM	INDOOR BLOWER MOTOR	TDC	TIME DELAY CONTROL WIRE NUT

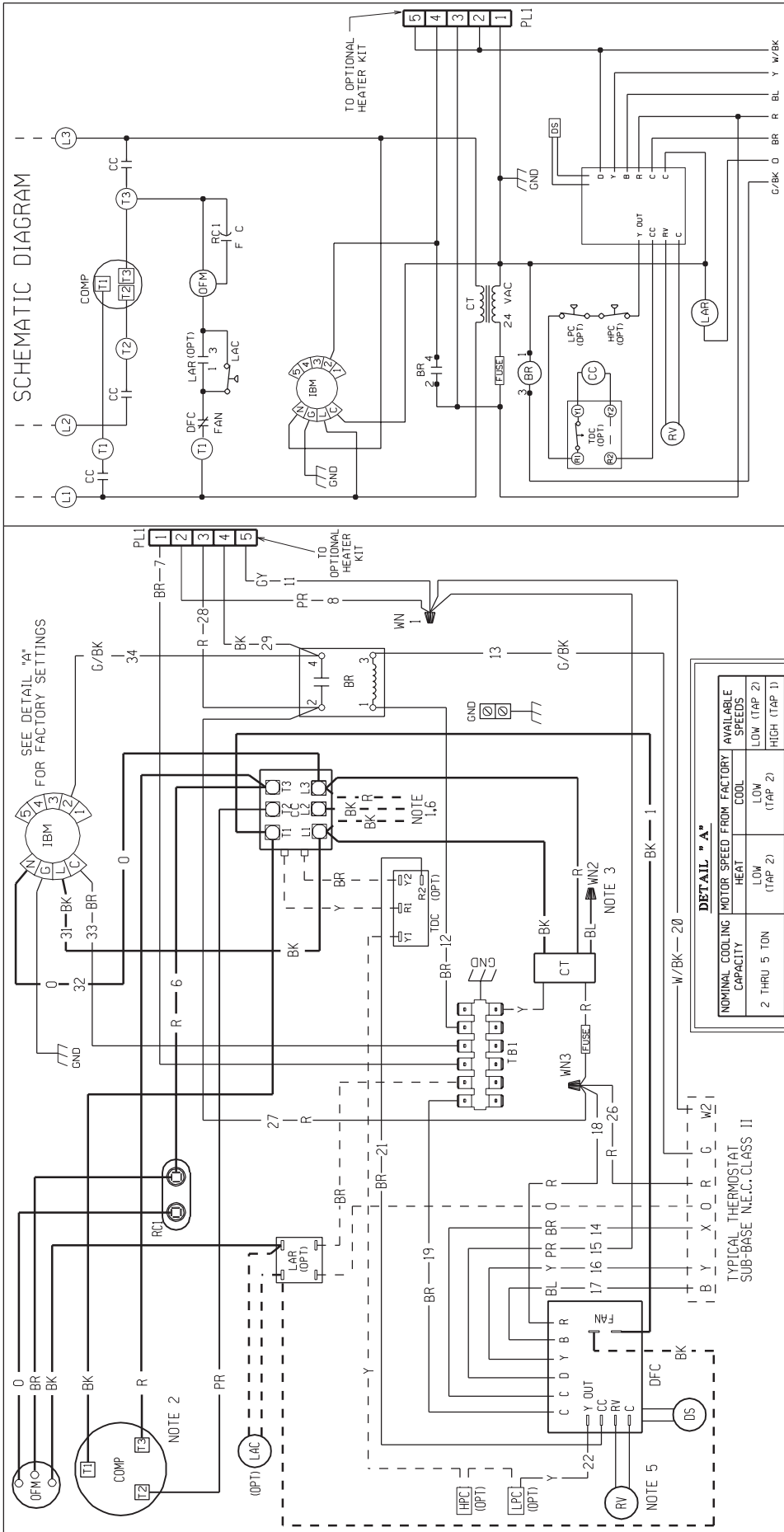

SCHEMATIC DIAGRAM

COMPONENT CODE

ALC AUX. LIMIT CONTROL
 BR BLOWER RELAY
 CC COMPRESSOR CONTACTOR
 CCH CRANKCASE HEATER
 COMP COMPRESSOR
 CT CONTROL TRANSFORMER
 DFC DEFROST CONTROL
 DR DEFROST RELAY
 DS DEFROST SENSOR
 GND GROUNDING BLOCK
 HPC HIGH PRESSURE CONTROL
 IBY INDOOR BLOWER MOTOR

LAC LOW AMBIENT COOLING CONTROL
 LAR LOW AMBIENT RELAY
 OFM OUTDOOR FAN MOTOR
 OPT OPTIONAL
 PL PLUG
 RC RUN CAPACITOR
 RV REVERSING VALVE
 TB TERMINAL BLOCK
 TBC TIME DELAY CONTROL
 WIRE WIRE NUT

WIRE COLOR CODE

BK ___BLACK GY ___GRAY R ___RED
 BR ___BROWN O ___ORANGE W ___WHITE
 BL ___BLUE PK ___PINK Y ___YELLOW
 G ___GREEN PR ___PURPLE

ELECTRICAL WIRING DIAGRAM

PACKAGE HEAT PUMP

3 PH, 208/230 VOLT - 60 HZ

DR. BY APP. BY DATE DWG. NO. REV
 JRJ 7-13-05 90-23621-17 02

WIRING INFORMATION

LINE VOLTAGE
 -FACTORY STANDARD
 -FACTORY OPTION
 -FIELD INSTALLED

LOW VOLTAGE
 -FACTORY STANDARD
 -FACTORY OPTION
 -FIELD INSTALLED

REPLACEMENT WIRE
 -MUST BE THE SAME SIZE AND TYPE OF INSULATION AS ORIGINAL (105 C° MIN.)
 WARNING
 -CABINET MUST BE PERMANENTLY GROUNDED AND CONFORM TO I.E.C., N.E.C., C.E.C. AND LOCAL CODES AS APPLICABLE.

NOTES:

- CONNECTORS SUITABLE FOR USE WITH COPPER CONDUCTORS ONLY.
- COMPRESSOR MOTOR THERMALLY PROTECTED.
- TRANSFORMER FACTORY WIRE FOR 230 VOLTS. USE RED AND BLUE LEADS FOR 208 VOLTS.
- MOTOR FACTORY WIRE FOR LOW SPEED. SEE AIRFLOW TABLES IN INSTALLATION INSTRUCTIONS TO DETERMINE CORRECT SPEED FOR UNIT APPLICATION.
- THIS COMPONENT ENERGIZED IN HEATING.
- FIELD WIRING OR CONNECTION FROM HEATER KIT FUSE BLOCK.

DETAIL # A*

NOMINAL COOLING CAPACITY	MOTOR SPEED	HEAT	COOL	FACTORY AVAILABLE SPEEDS
2 THRU 5 TON	LOW (TAP 2)	LOW (TAP 2)	LOW (TAP 2)	HIGH (TAP 1)

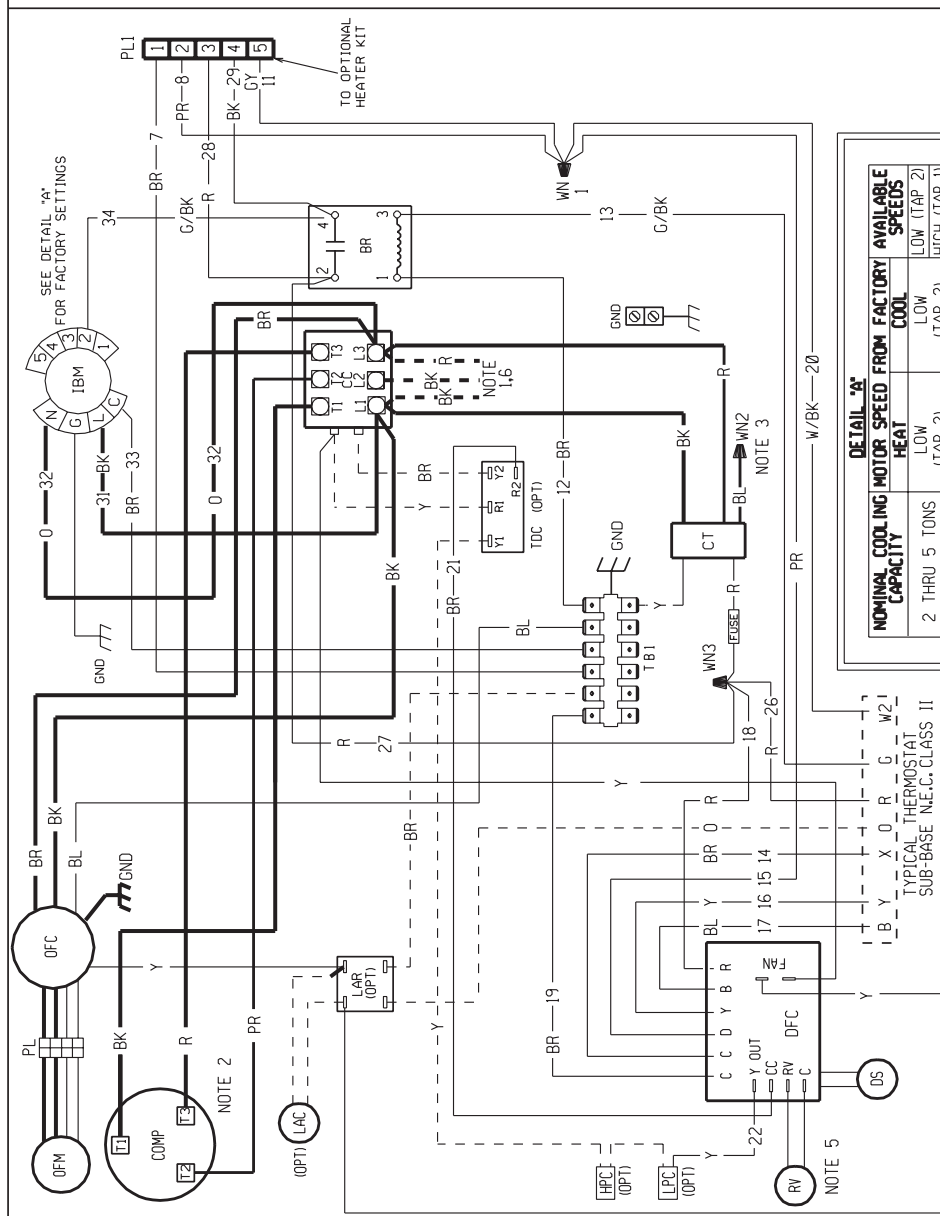
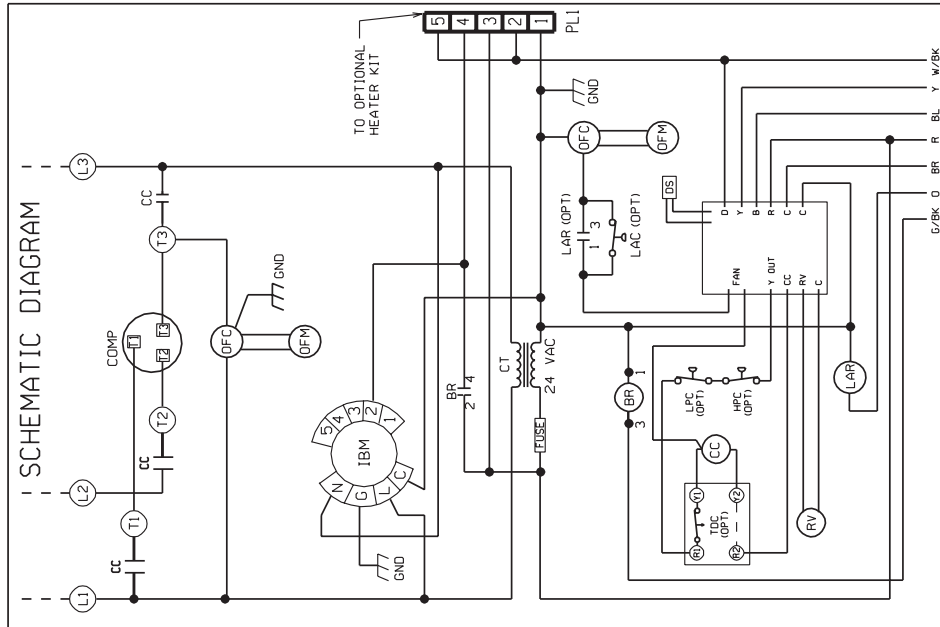

WIRE COLOR CODE

BK	BLACK	GY	GRAY	R	RED
BR	BROWN	O	ORANGE	W	WHITE
BL	BLUE	PK	PINK	Y	YELLOW
G	GREEN	PR	PURPLE	CL	CLEAR

ELECTRICAL WIRING DIAGRAM PACKAGE HEAT PUMP WITH INDOOR X-MOTOR AND OUTDOOR REMOTE CONTROL ECM

3 PH, 208/230 VOLT - 60 HZ
 DR. BY DATE DWG. NO.
 MGR 8-6-09 90-23621-23 REV 02

WIRING INFORMATION

- LINE VOLTAGE
- FACTORY STANDARD
- FACTORY OPTION
- FIELD INSTALLED
- LOW VOLTAGE
- FACTORY STANDARD
- FACTORY OPTION
- FIELD INSTALLED
- REPLACEMENT WIRE
- MUST BE THE SAME SIZE AND TYPE OF INSULATION AS ORIGINAL (105 C MIN.)

WARNING
 -CABINET MUST BE PERMANENTLY GROUNDED AND CONFORM TO I.E.C., N.E.C., C.E.C. AND LOCAL CODES AS APPLICABLE.

DETAIL 'A'

NOMINAL COOLING CAPACITY	MOTOR SPEED FROM FACTORY	COOL SPEEDS	AVAILABLE SPEEDS
2 THRU 5 TONS	LOW (TAP 2)	LOW	LOW (TAP 2)
	HIGH (TAP 1)	HIGH	HIGH (TAP 1)

DETAIL 'B'

NOMINAL HEATING CAPACITY	MOTOR SPEED FROM FACTORY	HEAT SPEEDS	AVAILABLE SPEEDS
2 THRU 5 TONS	LOW (TAP 2)	LOW	LOW (TAP 2)
	HIGH (TAP 1)	HIGH	HIGH (TAP 1)

NOTES:

- CONNECTORS SUITABLE FOR USE WITH COPPER CONDUCTORS ONLY.
- COMPRESSOR MOTOR THERMALLY PROTECTED.
- TRANSFORMER FACTORY WIRE FOR 230 VOLTS. USE RED AND BLUE LEADS FOR 208 VOLTS.
- MOTOR FACTORY WIRE FOR LOW SPEED. SEE AIRFLOW TABLES IN INSTALLATION INSTRUCTIONS TO DETERMINE CORRECT SPEED FOR UNIT APPLICATION.
- THIS COMPONENT ENERGIZED IN HEATING.
- FIELD WIRING OR CONNECTION FROM HEATER KIT FUSE BLOCK.

COMPONENT CODE

ALC	AUX LIMIT CONTROL	LAC	LOW AMBIENT COOLING
BLR	BLOWER RELAY	LAR	LOW AMBIENT RELAY
CC	COMPRESSOR CONTACTOR	OCF	OUTDOOR FAN CONTROL
CCH	CRANKCASE HEATER	OFM	OUTDOOR FAN MOTOR
COMP	COMPRESSOR	OPT	OPTIONAL
CT	CONTROL TRANSFORMER	PL	PLUG
DFC	DEFROST CONTROL	RC	RUN CAPACITOR
DR	DEFROST RELAY	RV	REVERSING VALVE
DS	DEFROST SENSOR	TBC	TERMINAL BLOCK
GND	GROUND	TDC	TIME DELAY CONTROL
HGS	HOT GAS SENSOR	W	WIRE NUT
HPC	HIGH PRESSURE CONTROL		
IBM	INDOOR BLOWER MOTOR		

BEFORE PURCHASING THIS APPLIANCE, READ IMPORTANT ENERGY COST AND EFFICIENCY INFORMATION AVAILABLE FROM YOUR RETAILER.

GENERAL TERMS OF LIMITED WARRANTY

Rheem will furnish a replacement for any part of this product which fails in normal use and service within the applicable periods stated, in accordance with the terms of the limited warranty.

***For Complete Details of the Limited Warranty, Including Applicable Terms and Conditions, See Your Local Installer or Contact the Manufacturer for a Copy.**

Compressor
1 Phase, Residential ApplicationsTen (10) Years
13 & 14 SEER, Commercial ApplicationsFive (5) Years
Conditional Parts* (1 Phase – Residential)
(Registration Required)Ten (10) Years
1 & 3 Phase, Commercial ApplicationsOne (1) Year

Before proceeding with installation, refer to installation instructions packaged with each model, as well as complying with all Federal, State, Provincial, and Local codes, regulations, and practices.

**Rheem Heating,
Cooling and
Water Heating**

P.O. Box 17010, Fort Smith, AR 72917



"In keeping with its policy of continuous progress and product improvement, Rheem reserves the right to make changes without notice."