



# SUBMITTAL COVER SHEET

PROJECT NAME \_\_\_\_\_

LOCATION \_\_\_\_\_

ARCHITECT \_\_\_\_\_

ENGINEER \_\_\_\_\_

CONTRACTOR \_\_\_\_\_

SUBMITTED BY \_\_\_\_\_ DATE \_\_\_\_\_

## UNIT SUMMARY

Quantity						
Unit Designation						
Model No.						
Total Cooling						
Sensible Cooling						
Air Ent. Evaporator						
Air Lvg. Evaporator						
Heating Input						
Heating Output						
CFM/ESP						
EER/SEER						
Electrical						
Minimum Ampacity						
Min.-Max. Breaker						
Net Unit Weight						
Accessory						
Catalog Form Number						

**ACCESSORIES:**

**NOTES:**

# SUBMITTAL SHEET FOR RHPN- ULTRA HIGH EFFICIENCY AIR HANDLER 2 NOMINAL TON [7.03 kW]

JOB NAME \_\_\_\_\_ LOCATION \_\_\_\_\_  
 CONTRACTOR \_\_\_\_\_ ORDER NO. \_\_\_\_\_  
 ENGINEER \_\_\_\_\_ SUBMITTED FOR  APPROVAL  RECORD  
 DATE \_\_\_\_\_ OUTDOOR UNIT MODEL NO. \_\_\_\_\_  
 MODEL NO. \_\_\_\_\_ INDOOR COIL MODEL NO. \_\_\_\_\_



## UNIT DATA

### COOLING PERFORMANCE

TOTAL CAPACITY\* ..... MBH [kW]  
 SENSIBLE CAPACITY\* ..... MBH [kW]  
 OUTDOOR DESIGN TEMP. .... °F [°C] DB  
 TOTAL SUPPLY AIR ..... CFM [L/s]  
 TEMP. OF AIR ENTERING  
 EVAPORATOR COIL ..... °F [°C] DB  
 °F [°C] WB  
 POWER INPUT REQUIREMENT ..... kW  
 (\*uses blower motor heat)

### HEATING PERFORMANCE

TOTAL CAPACITY\* ..... MBH [kW]  
 OUTDOOR DESIGN TEMP. .... °F [°C] DB  
 TEMP. OF AIR ENTERING  
 EVAPORATOR COIL ..... °F [°C] DB  
 ELECTRIC HEAT CAPACITY ..... kW  
 POWER INPUT REQUIREMENT ..... kW  
 (\*uses blower motor heat)

### SUPPLY AIR BLOWER PERFORMANCE

TOTAL AIR SUPPLY ..... CFM [L/s]  
 TOTAL RESISTANCE EXTERNAL  
 TO UNIT ..... IWG  
 BLOWER SPEED ..... RPM  
 POWER OUTPUT REQUIREMENT .. BHP  
 MOTOR RATING ..... HP [W]  
 POWER INPUT REQUIREMENT ..... kW

### ELECTRICAL DATA

POWER SUPPLY ..... Hz  
 TOTAL UNIT AMPACITY ..... AMPS  
 MINIMUM WIRE SIZE ..... AWG  
 MAXIMUM OVERCURRENT DEVICE  
 FUSES/HACR BREAKER ..... AMPS

### CLEARANCES

SERVICE ACCESS FRONT 24" [609.6 mm]



## FEATURES FOR RHPN- AIR HANDLERS 2 NOMINAL TON [7.03 kW]

- Includes an energy efficient GE® ECM® Motor, which in most applications, enhances the SEER rating of the outdoor unit. It also slowly ramps its speed up for quiet operation and enhanced customer satisfaction.
- Versatile 4-way convertible design for upflow, downflow, horizontal left and horizontal right applications.
- Nominal airflow up to 1.0" external static pressure.
- Factory-installed high efficiency indoor coil.
- Sturdy cabinet construction with 1.0 inch [25.4 mm] of foil faced insulation for excellent sound and insulating characteristics.
- Field-installed auxiliary electric heater kits provide exact heat for indoor comfort. Kits include circuit breakers which meet U.L. and cUL requirements for service disconnect.
- On-demand dehumidification terminal that adjusts airflow to help control humidity for unsurpassed comfort in cooling mode.
- Dip switch settings for selectable, customized cooling airflow over a wide variety of applications when wired in 24V conventional configurations.
- Blower self-configures when installed with a communicating outdoor unit and the Manufacturer's 500-Series thermostat.
- Equipment features a 10-year limited parts warranty. See warranty card for complete details.
- Advanced controls provide more comfort and diagnostic options.

[ ] Designates Metric Conversions



# Unit Dimensions

ELECTRICAL CONNECTIONS  
MAY EXIT TOP OR EITHER SIDE

HIGH VOLTAGE CONNECTION 7/8" [22.2 mm],  
1 3/32" [27.8 mm], 1 3/32" [50 mm]  
DIA. KNOCKOUT

LOW VOLTAGE CONNECTION  
5/8" [15.9 mm] AND 7/8" [22.2 mm] KNOCKOUT

AUXILIARY DRAIN CONNECTION  
3/4" [19.1 mm] FEMALE PIPE THREAD (NPT)  
HORIZONTAL APPLICATION ONLY

PRIMARY DRAIN CONNECTION  
3/4" [19.1 mm] FEMALE PIPE THREAD (NPT)

AUXILIARY DRAIN CONNECTION  
3/4" [19.1 mm] FEMALE PIPE THREAD (NPT)  
UPFLOW/DOWNFLOW APPLICATION ONLY

LIQUID LINE CONNECTION  
COPPER (SWEAT)

VAPOR LINE CONNECTION  
COPPER (SWEAT)

**DOWNFLOW APPLICATION AND HORIZONTAL RIGHT**  
INDOOR COIL AND COIL DOOR ROTATES 180°

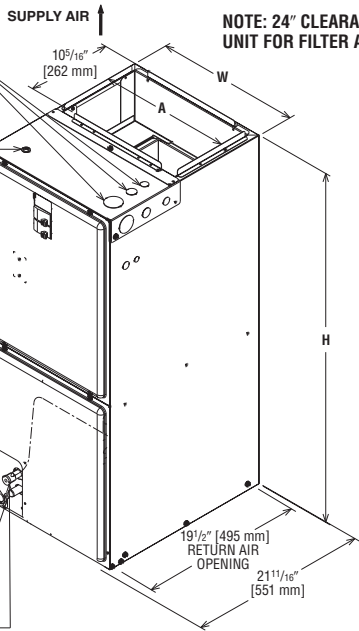
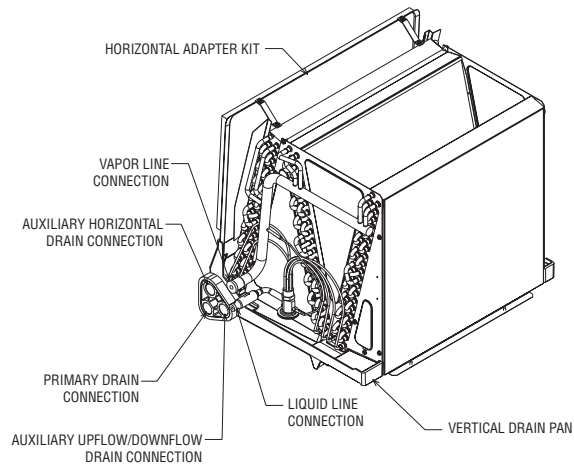

## Return Air Opening Dimensions

Model Cabinet Size	Return Air Opening Width (Inches)	Return Air Opening Depth/Length (Inches)
21	19 3/8	19 1/2
24	22 7/8	19 1/2

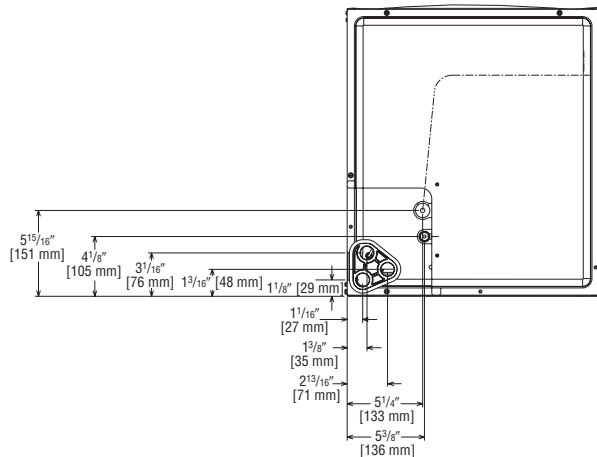

**UPFLOW UNIT SHOWN:**  
UNIT MAY BE INSTALLED UPFLOW,  
DOWNFLOW, HORIZONTAL RIGHT  
OR LEFT AIR SUPPLY.

[ ] Designates Metric Conversions  
( ) Designates Unit with Double Coil Cabinet

## Unit Dimensions & Weights

RHPN-	Unit Width "W" In. [mm]	Unit Height "H" In. [mm]	Supply Duct "A" In. [mm]	Matched to Outdoor Unit	Nominal Coil Airflow [L/s]				Unit Weight/Shipping Weight (Lbs.) [kg]	
					1st Stage		2nd Stage		Unit With Coil (Max. KW)	
					ODD*	Normal	ODD*	Normal		
2421	21 [533]	42 1/2 [1080]	19 1/2 [495]	(-)ARL/(-)ASL-024JEC	500 [238]	600 [283]	860 [307]	775 [366]	92/106	[42]/[48]
3624	24 1/2 [622]	55 1/2 [1410]	23 [584]	(-)ASL-036JEC	725 [342]	825 [389]	975 [460]	1175 [555]	181/198	[82]/[90]
				(-)ARL/(-)ASL-036JEC	825 [389]	950 [448]	1000 [472]	1175 [555]		
4824	24 1/2 [622]	55 1/2 [1410]	23 [584]	(-)ASL-048JEC	825 [389]	1000 [472]	1300 [614]	1600 [755]	181/198	[82]/[90]
				(-)ARL-048JEC	1000 [472]	1200 [566]	1350 [637]	1600 [755]		
6024	24 1/2 [622]	55 1/2 [1410]	23 [584]	(-)ASL-060JEC	925 [437]	1050 [496]	1325 [625]	1700 [802]	181/198	[82]/[90]
				(-)ARL-060JEC	1025 [484]	1275 [602]	1400 [661]	1700 [802]		

\*Maximum dehumidification airflow. Refer to interface board section for more information.

[ ] Designates Metric Conversions

**Before proceeding with installation, refer to installation instructions packaged with each model, as well as complying with all Federal, State, Provincial, and Local codes, regulations, and practices.**

Rheem Sales Company, Inc.  
P.O. Box 17010, Fort Smith, AR 72917

"In keeping with its policy of continuous progress and product improvement, Rheem reserves the right to make changes without notice."