

INSTALLATION INSTRUCTIONS

AIR-COOLED CONDENSING UNITS

(-)ARL-JEC 16 SEER

EQUIPPED WITH THE *COMFORT CONTROL² SYSTEM™*

Comfort Control² System™



Featuring Earth-Friendly
R-410A Refrigerant 



RECOGNIZE THIS SYMBOL AS AN INDICATION OF IMPORTANT SAFETY INFORMATION!

▲ WARNING

THESE INSTRUCTIONS ARE INTENDED AS AN AID TO QUALIFIED, LICENSED SERVICE PERSONNEL FOR PROPER INSTALLATION, ADJUSTMENT AND OPERATION OF THIS UNIT. READ THESE INSTRUCTIONS THOROUGHLY BEFORE ATTEMPTING INSTALLATION OR OPERATION. FAILURE TO FOLLOW THESE INSTRUCTIONS MAY RESULT IN IMPROPER INSTALLATION, ADJUSTMENT, SERVICE OR MAINTENANCE POSSIBLY RESULTING IN FIRE, ELECTRICAL SHOCK, PROPERTY DAMAGE, PERSONAL INJURY OR DEATH.

UL
C US
LISTED



ISO 9001:2000
Certificate Number: 30164

DO NOT DESTROY THIS MANUAL

PLEASE READ CAREFULLY AND KEEP IN A SAFE PLACE FOR FUTURE REFERENCE BY A SERVICEMAN

TABLE OF CONTENTS

1.0	SAFETY INFORMATION	3
2.0	GENERAL INFORMATION	5
2.1	Checking Product Received	5
2.2	Application	5
2.3	Dimensions	6
2.4	Electrical and Physical Data	6
2.5	Proper Installation	7
3.0	LOCATING UNIT	7
3.1	Corrosive Environment	7
3.2	Condenser Location	7
3.3	Operational Issues	8
3.4	For Condensers With Space Limitations	8
3.5	Customer Satisfaction Issues	8
3.6	Unit Mounting	8
3.7	Factory-Preferred Tie-Down Method	8
4.0	REFRIGERANT CONNECTIONS	9
4.1	Tools Required for Installing & Servicing R-410A Models	9
4.2	Specifications of R-410A	10
4.3	Quick Reference Guide for R-410-A	10
5.0	REPLACEMENT UNITS	11
6.0	INDOOR COIL	11
6.1	Location	11
7.0	INTERCONNECTING TUBING	11
7.1	Vapor and Liquid Lines	11
7.2	Maximum Length of Lines	12
7.3	Outdoor Unit Installed Above or Below Indoor Coil	12
7.4	Tubing Installation	13
7.5	Tubing Connections	15
7.6	Leak Testing	15
8.0	COMPRESSOR CRANKCASE HEAT (CCH)	15
9.0	HARD START COMPONENTS	16
10.0	HIGH AND LOW PRESSURE CONTROLS (HPC AND LPC)	16
10.1	Evacuation Procedure	16
11.0	CONDENSING UNITS EQUIPPED WITH THE COMFORT CONTROL² SYSTEMTM	17
11.1	Control Description	17
11.2	Comfort Control ² System TM Control Wiring	18
11.3	Comfort Control ² System TM ICC Control Operation	18
11.4	Active Compressor Protection Mode	20
11.5	Test and Fault Recall Modes	22
11.6	ICC Diagnostic Codes	24-27
11.7	Conventional 24VAC Thermostat Control Wiring	27
11.8	Typical Non-Communicating Thermostat Wiring Diagrams	28
11.9	ICC Control Operation with Conventional Thermostat Wiring	29
11.10	Active Compressor Protection Mode	30
11.11	Test and Fault Recall Modes	31
12.0	ELECTRICAL WIRING	33
12.1	Power Wiring	33
12.2	Grounding	33
12.3	Control Wiring	33
13.0	START-UP AND PERFORMANCE	34
14.0	CHECKING AIRFLOW	34
15.0	CHECKING REFRIGERANT CHARGE	34
15.1	Charging Units With R-410A Refrigerant	35
15.2	Charging By Liquid Pressure	35
15.3	Charging By Weight	35
15.4	Final Leak Testing	35
16.0	ACCESSORIES	36
16.1	Remote Outdoor Temperature Model	36
17.0	TROUBLESHOOTING	36
17.1	Comfort Control ² System TM Initial Startup	36
17.2	Replacement of Comfort Control ² System TM Control Board	37
17.3	Electrical Checks Flow Chart	38
17.4	Cooling Mechanical Checks Flow Chart	39
17.5	General Trouble Shooting Chart	40
17.6	Service Analyzer Charts	41-45
17.7	Subcooling Calculation	46
18.0	WIRING DIAGRAMS	47-48

1.0 SAFETY INFORMATION

WARNING

THESE INSTRUCTIONS ARE INTENDED AS AN AID TO QUALIFIED, LICENSED SERVICE PERSONNEL FOR PROPER INSTALLATION, ADJUSTMENT AND OPERATION OF THIS UNIT. READ THESE INSTRUCTIONS THOROUGHLY BEFORE ATTEMPTING INSTALLATION OR OPERATION. FAILURE TO FOLLOW THESE INSTRUCTIONS MAY RESULT IN IMPROPER INSTALLATION, ADJUSTMENT, SERVICE OR MAINTENANCE POSSIBLY RESULTING IN FIRE, ELECTRICAL SHOCK, PROPERTY DAMAGE, PERSONAL INJURY OR DEATH.

WARNING

THE MANUFACTURER'S WARRANTY DOES NOT COVER ANY DAMAGE OR DEFECT TO THE AIR CONDITIONER CAUSED BY THE ATTACHMENT OR USE OF ANY COMPONENTS, ACCESSORIES OR DEVICES (OTHER THAN THOSE AUTHORIZED BY THE MANUFACTURER) INTO, ONTO OR IN CONJUNCTION WITH THE AIR CONDITIONER. YOU SHOULD BE AWARE THAT THE USE OF UNAUTHORIZED COMPONENTS, ACCESSORIES OR DEVICES MAY ADVERSELY AFFECT THE OPERATION OF THE AIR CONDITIONER AND MAY ALSO ENDANGER LIFE AND PROPERTY. THE MANUFACTURER DISCLAIMS ANY RESPONSIBILITY FOR SUCH LOSS OR INJURY RESULTING FROM THE USE OF SUCH UNAUTHORIZED COMPONENTS, ACCESSORIES OR DEVICES.

WARNING

DISCONNECT ALL POWER TO UNIT BEFORE STARTING MAINTENANCE. FAILURE TO DO SO CAN CAUSE ELECTRICAL SHOCK RESULTING IN SEVERE PERSONAL INJURY OR DEATH.

WARNING

DO NOT USE OXYGEN TO PURGE LINES OR PRESSURIZE SYSTEM FOR LEAK TEST. OXYGEN REACTS VIOLENTLY WITH OIL, WHICH CAN CAUSE AN EXPLOSION RESULTING IN SEVERE PERSONAL INJURY OR DEATH.

WARNING

THE UNIT MUST BE PERMANENTLY GROUNDED. FAILURE TO DO SO CAN CAUSE ELECTRICAL SHOCK RESULTING IN SEVERE PERSONAL INJURY OR DEATH.

WARNING

TURN OFF ELECTRIC POWER AT THE FUSE BOX OR SERVICE PANEL BEFORE MAKING ANY ELECTRICAL CONNECTIONS.

ALSO, THE GROUND CONNECTION MUST BE COMPLETED BEFORE MAKING LINE VOLTAGE CONNECTIONS. FAILURE TO DO SO CAN RESULT IN ELECTRICAL SHOCK, SEVERE PERSONAL INJURY OR DEATH.

Continued on next page →

⚠ CAUTION

R-410A systems operate at higher pressures than R-22 systems. Do not use R-22 service equipment or components on R-410A equipment.

⚠ CAUTION

Only use evaporators approved for use on R-410A systems. Use of existing R-22 evaporators can introduce mineral oil to the R-410A refrigerant forming two different liquids and decreasing oil return to the compressor. This can result in compressor failure.

⚠ CAUTION

When coil is installed over a finished ceiling and/or living area, it is recommended that a secondary sheet metal condensate pan be constructed and installed under entire unit. Failure to do so can result in property damage.

⚠ CAUTION

THE COMPRESSOR HAS AN INTERNAL OVERLOAD PROTECTOR. UNDER SOME CONDITIONS, IT CAN TAKE UP TO 2 HOURS FOR THIS OVERLOAD TO RESET. MAKE SURE OVERLOAD HAS HAD TIME TO RESET BEFORE CONDEMNING THE COMPRESSOR.

⚠ CAUTION

UNIT MAY START SUDDENLY AND WITHOUT WARNING
Solid red light indicates a thermostat call for unit operation is present at the ICC control. ICC control will attempt to start unit after short cycle timer expires or when in Active Protection mode will attempt to restart unit prior to Lockout mode.

⚠ CAUTION

UNIT MAY START SUDDENLY AND WITHOUT WARNING
Solid red light indicates a thermostat call for unit operation is present at the ICC. ICC will attempt to start unit after short cycle timer expires or when in Active Protection mode will attempt to restart unit prior to Lockout mode.

⚠ CAUTION

THE TOP OF THE SCROLL COMPRESSOR SHELL IS HOT. TOUCHING THE COMPRESSOR TOP MAY RESULT IN SERIOUS PERSONAL INJURY.

⚠ CAUTION

R-410A PRESSURES ARE APPROXIMATELY 60% HIGHER THAN R-22 PRESSURES. USE APPROPRIATE CARE WHEN USING THIS REFRIGERANT. FAILURE TO EXERCISE CARE MAY RESULT IN EQUIPMENT DAMAGE, OR PERSONAL INJURY.

WARNING

THE MANUFACTURER'S WARRANTY DOES NOT COVER ANY DAMAGE OR DEFECT TO THE AIR CONDITIONER CAUSED BY THE ATTACHMENT OR USE OF ANY COMPONENTS, ACCESSORIES OR DEVICES (OTHER THAN THOSE AUTHORIZED BY THE MANUFACTURER) INTO, ONTO OR IN CONJUNCTION WITH THE AIR CONDITIONER. YOU SHOULD BE AWARE THAT THE USE OF UNAUTHORIZED COMPONENTS, ACCESSORIES OR DEVICES MAY ADVERSELY AFFECT THE OPERATION OF THE AIR CONDITIONER AND MAY ALSO ENDANGER LIFE AND PROPERTY. THE MANUFACTURER DISCLAIMS ANY RESPONSIBILITY FOR SUCH LOSS OR INJURY RESULTING FROM THE USE OF SUCH UNAUTHORIZED COMPONENTS, ACCESSORIES OR DEVICES.

MATCH ALL COMPONENTS:

- OUTDOOR UNIT
- INDOOR COIL/METERING DEVICE
- INDOOR AIR HANDLER/FURNACE
- REFRIGERANT LINES

2.0 GENERAL INFORMATION

The (-)ARL-series of condensing units are designed to operate using the *Comfort Control*² or traditional 24VAC controls. These units are equipped with *Comfort Control*². To take full advantage of the *Comfort Control*² System™, the preferred method of installation is using the *Comfort Control*². Your installation must have these components to use the *Comfort Control*²:

- (-)ARL condensing unit equipped with *Comfort Control*²
- An air handler or furnace equipped with *Comfort Control*²
- A *Comfort Control*² thermostat

If your installation does not meet the above requirements, you must use traditional 24VAC controls.

This installation instruction manual contains complete instructions for installation and setup using *Comfort Control*² or conventional 24VAC controls. Please refer to the engineering Specification Sheets for complete performance data, thermostat, and accessory listings.

The information contained in this manual has been prepared to assist in the proper installation, operation and maintenance of the air conditioning system. Improper installation, or installation not made in accordance with these instructions, can result in unsatisfactory operation and/or dangerous conditions (noise and component failure), and can cause the related warranty not to apply.

Read this manual and any instructions packaged with separate equipment required to make up the system prior to installation. Retain this manual for future reference.

To achieve optimum efficiency and capacity, the indoor cooling coils listed in the condensing unit specification sheet should be used.

2.1 CHECKING PRODUCT RECEIVED

Upon receiving unit, inspect it for any shipping damage. Claims for damage, either apparent or concealed, should be filed immediately with the shipping company. Check condensing unit model number, electrical characteristics and accessories to determine if they are correct. Check system components (evaporator coil, condensing unit, evaporator blower, etc.) to make sure they are properly matched.

2.2 APPLICATION

Before specifying any air conditioning equipment, a survey of the structure and a heat gain calculation must be made. A heat gain calculation begins by measuring all external surfaces and openings that gain heat from the surrounding air and quantifying that heat gain. A heat gain calculation also calculates the extra heat load caused by sunlight and by humidity removal.

Air conditioning systems are sized on the cooling load calculation. There are two capacities that enable the equipment to provide comfort. The first is sensible capacity.

Sensible heat is the heat energy measured on the dry bulb thermometer as it is added or removed.

The second form of heat is called **latent** or **hidden heat**. This is heat held in the humidity in the air.

A properly-sized unit removes both forms of heat, producing a comfortable living space. An oversized system cycles on and off too quickly and does not properly remove humidity, producing an uncomfortable living space. Select the indoor and outdoor equipment combination based on the manufacturer's engineering data.

After the equipment combination has been selected, satisfying both sensible and latent conditioning requirements, the system must be properly installed. Only then can the unit provide the comfort the manufacturer intends.

There are several factors that the installers must consider:

- Outdoor unit location
- System refrigerant charge
- Indoor unit blower speed
- System air balancing
- Proper equipment evacuation
- Indoor unit airflow
- Supply and return air duct design and sizing
- Diffuser and return air grille location and sizing

2.3 DIMENSIONS

FIGURE 1
DIMENSIONS AND INSTALLATION CLEARANCES

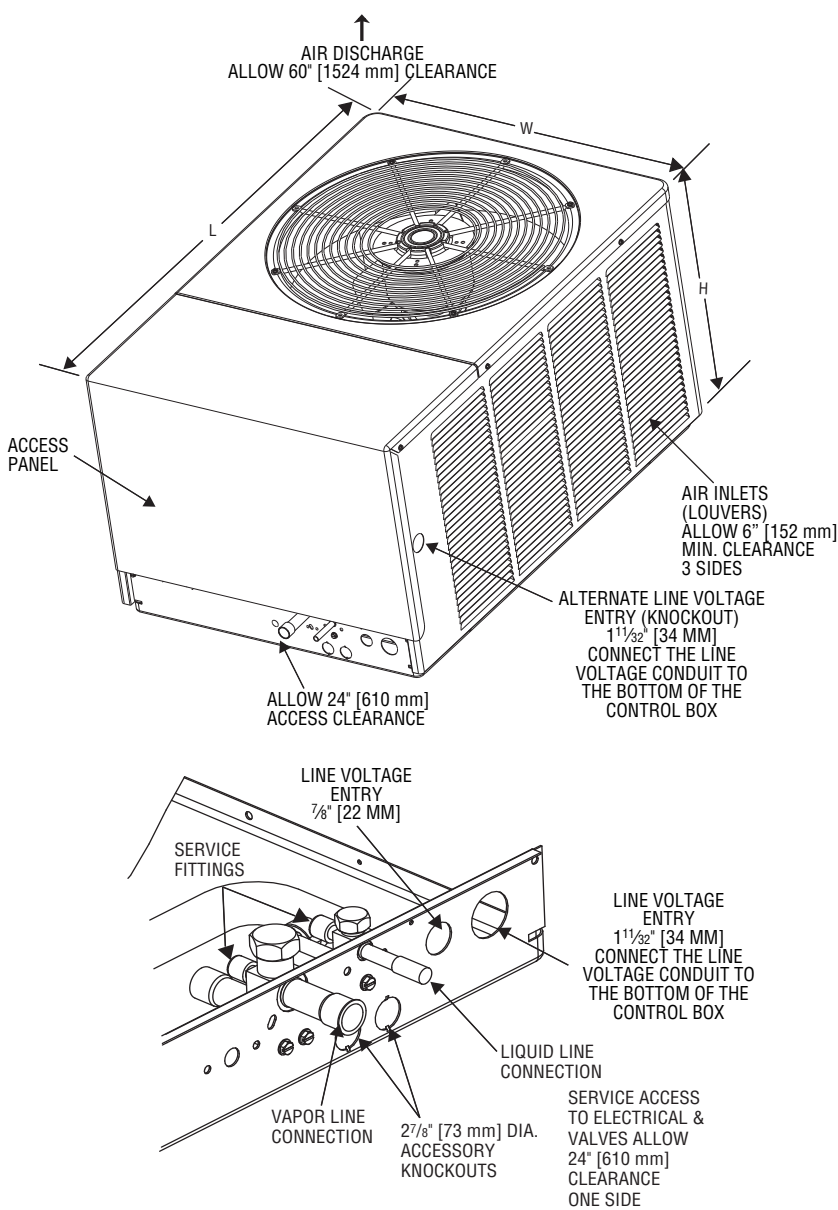

UNIT MODEL NUMBER EXPLANATION

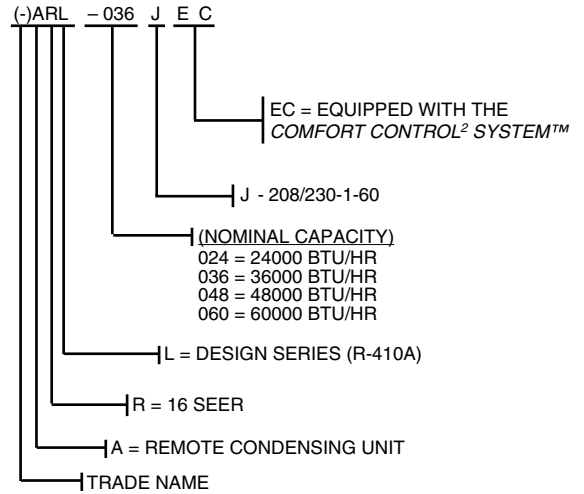

BASE PAN

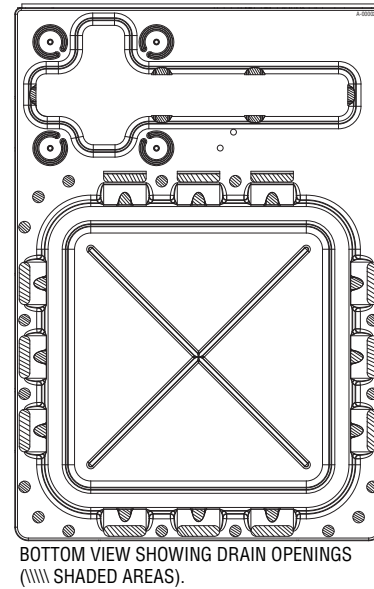

2.4 ELECTRICAL & PHYSICAL DATA

TABLE 1
(-)ARL-JEC ELECTRICAL DATA

Model Number	ELECTRICAL							PHYSICAL					DIMENSIONAL DATA			
	Phase Frequency (Hz) Voltage (Volts)	Compressor		Fan Motor (FLA)	Min. Circuit Ampacity Amperes	Fuse or HACR Circuit Breaker		Outdoor Coil			Weight		Height "H" (Inches)	Length "L" (Inches)	Width "W" (Inches)	
		(RLA)	(LRA)			Min. Amperes	Max. Amperes	Face Area Sq. Ft. [m²]	No. Rows	CFM [L/s]	R-410a Oz. [g]	Net Lbs. [kg]				Shipping Lbs. [kg]
(-)ARL-024JEC	1-60-208/230	10.3/10.3	52	0.8	14/14	20/20	20/20	15.8 [1.47]	1	2285 [1078]	117 [3311]	190 [86.2]	200 [90.7]	23	44-3/8	31-1/2
(-)ARL-036JEC	1-60-208/230	16.7/16.7	82	1.0	22/22	30/30	35/35	15.8 [1.47]	1	3900 [1841]	157 [4445]	236 [107]	246 [111.6]	33	44-3/8	31-1/2
(-)ARL-048JEC	1-60-208/230	21.2/21.2	96	1.0	28/28	35/35	45/45	15.8 [1.47]	1	3900 [1841]	154 [4354]	236 [107]	246 [111.6]	33	44-3/8	31-1/2
(-)ARL-060JEC	1-60-208/230	25.6/25.6	118	2.8	35/35	45/45	60/60	23.0 [2.14]	2	HS* 3500 [1652] LS* 2800 [1322]	224 [6250]	305 [138.4]	315 [142.8]	33	44-3/8	31-1/2

*HS = high speed
*LS = low speed

2.5 PROPER INSTALLATION

Proper sizing and installation of this equipment is critical to achieve optimal performance. Use the information in this Installation Instruction Manual and reference the applicable Engineering Specification Sheet when installing this product.

IMPORTANT: This product has been designed and manufactured to meet ENERGY STAR® criteria for energy efficiency when matched with appropriate coil components. However, proper refrigerant charge and proper airflow are critical to achieve rated capacity and efficiency. Installation of this product should follow the manufacturer's refrigerant charging and airflow instructions. **Failure to confirm proper charge and airflow may reduce energy efficiency and shorten equipment life.**

3.0 LOCATING UNIT

3.1 Corrosive Environment

The metal parts of this unit may be subject to rust or deterioration if exposed to a corrosive environment. This oxidation could shorten the equipment's useful life. Corrosive elements include, but are not limited to, salt spray, fog or mist in seacoast areas, sulphur or chlorine from lawn watering systems, and various chemical contaminants from industries such as paper mills and petroleum refineries.

If the unit is to be installed in an area where contaminants are likely to be a problem, special attention should be given to the equipment location and exposure.

- Avoid having lawn sprinkler heads spray directly on the unit cabinet.
- In coastal areas, locate the unit on the side of the building away from the waterfront.
- Shielding provided by a fence or shrubs may give some protection, but cannot violate minimum airflow and service access clearances.
- Elevating the unit off its slab or base enough to allow air circulation will help avoid holding water against the basepan.

Regular maintenance will reduce the build-up of contaminants and help to protect the unit's finish.

WARNING

DISCONNECT ALL POWER TO UNIT BEFORE STARTING MAINTENANCE. FAILURE TO DO SO CAN CAUSE ELECTRICAL SHOCK RESULTING IN SEVERE PERSONAL INJURY OR DEATH.

- Frequent washing of the cabinet, fan blade and coil with fresh water will remove most of the salt or other contaminants that build up on the unit.
- Regular cleaning and waxing of the cabinet with a good automobile polish will provide some protection.
- A good liquid cleaner may be used several times a year to remove matter that will not wash off with water.

Several different types of protective coatings are offered in some areas. These coatings may provide some benefit, but the effectiveness of such coating materials cannot be verified by the equipment manufacturer.

3.2 CONDENSER LOCATION

Consult local and national building codes and ordinances for special installation requirements. Following location information will provide longer life and simplified servicing of the outdoor condenser.

NOTE: These units must be installed outdoors. No ductwork can be attached, or other modifications made, to the discharge grille. Modifications will affect performance or operation.

3.3 Operational Issues

- **IMPORTANT:** Locate the unit in a manner that will not prevent, impair or compromise the performance of other equipment horizontally installed in proximity to the unit. Maintain all required minimum distances to gas and electric meters, dryer vents, exhaust and inlet openings. In the absence of National Codes, or manufacturers' recommendations, local code recommendations and requirements will take precedence.
- Refrigerant piping and wiring should be properly sized and kept as short as possible to avoid capacity losses and increased operating costs.
- Locate the unit where water run off will not create a problem with the equipment. Position the unit away from the drip edge of the roof whenever possible. Units are weatherized, but can be affected by the following:
 - o Water pouring into the unit from the junction of rooflines, without protective guttering. Large volumes of water entering the heat pump while in operation can impact fan blade or motor life, and coil damage may occur to a heat pump if moisture cannot drain from the unit under freezing conditions.
 - o Freezing moisture, or sleeting conditions, can cause the cabinet to ice-over prematurely and prevent heat pump operation, requiring backup heat, which generally results in less economical operation.
- Closely follow clearance recommendations on Page 6.
 - o 24" to the service panel access
 - o 60" above heat pump fan discharge (unit top) to prevent recirculation
 - o 6" to heat pump coil grille air inlets

3.4 For Units With Space Limitations FOR CONDENSERS WITH SPACE LIMITATIONS

In the event that a space limitation exists, we will permit the following clearances:

Single Unit Applications: Clearances below 6 inches will reduce unit capacity and efficiency. Do not reduce the 60-inch discharge, or the 24-inch service clearances.

Multiple Unit Applications: When multiple condenser grille sides are aligned, a 6-inch per unit clearance is recommended, for a total of 12" between two units. Two combined clearances below 12 inches will reduce capacity and efficiency. Do not reduce the 60-inch discharge, or 24-inch service, clearances.

3.5 Customer Satisfaction Issues

- The condensing unit should be located away from the living, sleeping and recreational spaces of the owner and those spaces on adjoining property.
- To prevent noise transmission, the mounting pad for the outdoor unit should not be connected to the structure, and should be located sufficient distance above grade to prevent ground water from entering the unit.

3.6 Unit Mounting

If elevating the condensing unit, either on a flat roof or on a slab, observe the following guidelines.

- The base pan provided elevates the heat pump 3/4" above the base pad.
- If elevating a unit on a flat roof, use 4" x 4" (or equivalent) stringers positioned to distribute unit weight evenly and prevent noise and vibration (see Figure 2).

NOTE: Do not block drain openings shown in Figure 1.

3.7 Factory-Preferred Tie-Down Method INSTRUCTIONS

IMPORTANT: These instructions are intended as a guide to securing equipment for wind-load ratings of "120 MPH sustained wind load" and "3-second, 150 MPH gust." While this procedure is not mandatory, the Manufacturer does recommend that equipment be properly secured in areas where high wind damage may occur.

STEP 1: Before installing, clear pad of any dirt or debris.

IMPORTANT: The pad must be constructed of industry-approved materials, and must be thick enough to accommodate the concrete fastener.

STEP 2: Center base pan on pad, ensuring it is level.

FIGURE 2
RECOMMENDED ELEVATED INSTALLATION

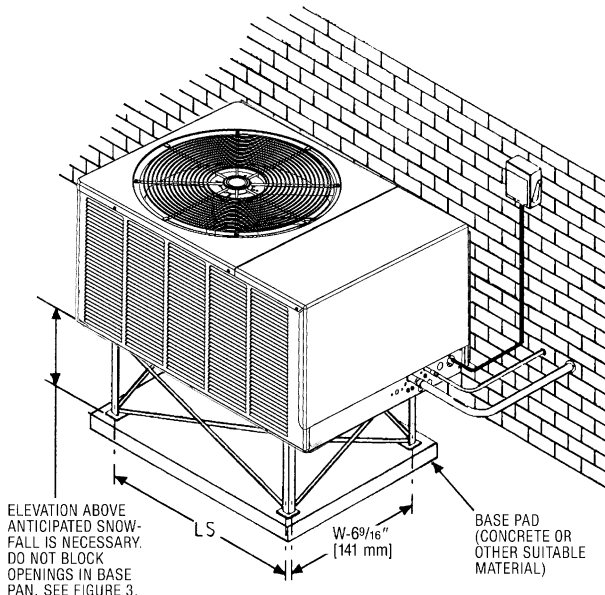

STEP 3: Using basepad as a guide, mark spots on concrete where 4 holes will be drilled (see Figure 3).

STEP 4: Drill four pilot holes in pad, ensuring that the hole is at least 1/4" deeper than the concrete screw being used.

STEP 5: Center basepan over pre-drilled holes and insert concrete screws.

STEP 6: Tighten concrete screws.

NOTE: Do not over-tighten the concrete screws. Doing so can weaken the integrity of the concrete screw and cause it to break.

STEP 7: Finish unit assembly per unit's installation instructions.

4.0 REFRIGERANT CONNECTIONS

All units are factory charged with Refrigerant 410A. All models are supplied with service valves. Keep tube ends sealed until connection is to be made to prevent system contamination.

4.1 Tools Required For Installing & Servicing R-410A Models

Manifold Sets:

- Up to 800 PSIG High side
- Up to 250 PSIG Low Side
- 550 PSIG Low Side Retard

Manifold Hoses:

- Service Pressure Rating of 800 PSIG

Recovery Cylinders:

- 400 PSIG Pressure Rating
- Dept. of Transportation 4BA400 or BW400

▲ CAUTION

R-410A systems operate at higher pressures than R-22 systems. Do not use R-22 service equipment or components on R-410A equipment.

FIGURE 3
SCREW LOCATIONS

(4) 1/4" CONCRETE SCREWS SNUG TO BASE PAN, LENGTH TO PENETRATE CONCRETE 1.5" MINIMUM. SCREWS HAVE TO BE PLACED ON THE BASE PAN AS SHOWN

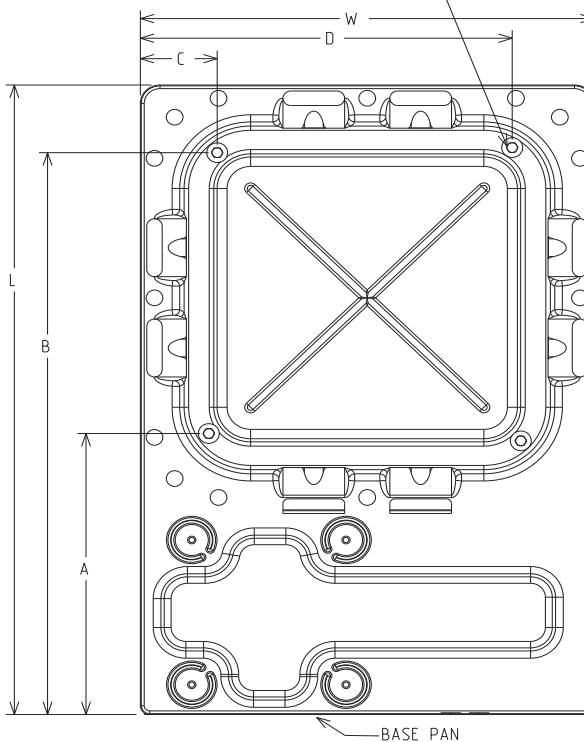

TABLE 2
DIMENSIONS

MODEL NUMBER	L	W	A	B	C	D
(-)ARL-024/036/048/060	41.5	29.813	15	38	3.5	26.5

4.2 Specifications of R-410A:

Application: **R-410A is not a drop-in replacement for R-22;** equipment designs must accommodate its higher pressures. It cannot be retrofitted into R-22 heat pumps.

Physical Properties: R-410A has an atmospheric boiling point of -62.9°F and its saturation pressure at 77°F is 224.5 psig.

Composition: R-410A is an azeotropic mixture of 50% by weight difluoromethane (HFC-32) and 50% by weight pentafluoroethane (HFC-125).

Pressure: **The pressure of R-410A is approximately 60% (1.6 times) greater than R-22.** Recovery and recycle equipment, pumps, hoses and the like need to have design pressure ratings appropriate for R-410A. *Manifold sets need to range up to 800 psig high-side and 250 psig low-side with a 550 psig low-side retard. Hoses need to have a service pressure rating of 800 psig. Recovery cylinders need to have a 400 psig service pressure rating. DOT 4BA400 or DOT BW400.*

Combustibility: At pressures above 1 atmosphere, mixture of R-410A and air can become combustible. **R-410A and air should never be mixed in tanks or supply lines, or be allowed to accumulate in storage tanks. Leak checking should never be done with a mixture of R-410A and air.** Leak checking can be performed safely with nitrogen or a mixture of R-410A and nitrogen.

4.3 Quick Reference Guide For R-410A

- R-410A refrigerant operates at approximately 60% higher pressure (1.6 times) than R-22. Ensure that servicing equipment is designed to operate with R-410A.
- R-410A refrigerant cylinders are pink in color.
- R-410A, as with other HFC's is only compatible with POE oils.

- Vacuum pumps will not remove moisture from oil.
- R-410A systems are to be charged with liquid refrigerants. Prior to March 1999, R-410A refrigerant cylinders had a dip tube. These cylinders should be kept upright for equipment charging. Post March 1999 cylinders do not have a dip tube and should be inverted to ensure liquid charging of the equipment.
- Do not install a suction line filter drier in the liquid line.
- A liquid line filter drier is standard on every unit. Only manufacturer approved liquid line filter driers can be used. These are Sporlan (CW083S) and Alco (80K083S) driers. These filter driers are rated for minimum working pressure of 600 psig.
- Desiccant (drying agent) must be compatible for POE oils and R-410A.

5.0 REPLACEMENT UNITS

To prevent failure of a new condensing unit, the existing evaporator tubing system must be correctly sized and cleaned or replaced. Care must be exercised that the expansion device is not plugged. For new and replacement units, a liquid line filter drier should be installed and refrigerant tubing should be properly sized. Test the oil for acid. If positive, a suction line filter drier is mandatory.

IMPORTANT: WHEN REPLACING AN R-22 UNIT WITH AN R-410A UNIT, EITHER REPLACE THE LINE SET OR ENSURE THAT THE EXISTING LINE SET IS THOROUGHLY CLEANED OF ANY OLD OIL OR DEBRIS.

6.0 INDOOR COIL

REFER TO INDOOR COIL MANUFACTURER'S INSTALLATION INSTRUCTIONS.

IMPORTANT: The manufacturer is not responsible for the performance and operation of a mismatched system, or for a match listed with another manufacturer's coil.

CAUTION

Only use evaporators approved for use on R-410A systems. Use of existing R-22 evaporators can introduce mineral oil to the R-410A refrigerant forming two different liquids and decreasing oil return to the compressor. This can result in compressor failure.

NOTE: All (-)JARL units must be installed with a TXV Evaporator.

The thermostatic expansion valve is specifically designed to operate with R-410A. **DO NOT use an R-22 TXV or evaporator. The existing evaporator must be replaced with the factory specified TXV evaporator specifically designed for R-410A.**

6.1 Location

Do not install the indoor coil in the return duct system of a gas or oil furnace. Provide a service inlet to the coil for inspection and cleaning. Keep the coil pitched toward the drain connection.

CAUTION

When coil is installed over a finished ceiling and/or living area, it is recommended that a secondary sheet metal condensate pan be constructed and installed under entire unit. Failure to do so can result in property damage.

7.0 INTERCONNECTING TUBING

7.1 Vapor and Liquid Lines

Keep all lines sealed until connection is made.

Make connections at the indoor coil first.

TABLE 3
VAPOR LINE CAPACITY MULTIPLIER

(-)ARL Unit Vapor Line Connection Size (inches I.D.) [mm]		024	036	048	060
		3/4" [19.05] I.D. Sweat	7/8" [22.23] I.D. Sweat	7/8" [22.23] I.D. Sweat	7/8" [22.23] I.D. Sweat
Vapor Line Run Feet [m]		Vapor Line Diameter (inches O.D.) [mm]			
		5/8" [15.88] Optional	5/8" [15.88] Optional	5/8" [15.88] Optional	3/4" [19.05] Optional
		3/4" [19.05] Standard	3/4" [19.05] Standard	3/4" [19.05] Standard	7/8" [22.23] Standard
		—	—	7/8" [22.23] Optional	—
25' [7.62]	Opt.	1.00	0.98	0.98	0.99
	Std.	1.00	1.00	1.00	1.00
	Opt.	N/A	N/A	1.02	N/A
50' [15.24]	Opt.	0.99	0.96	0.96	0.97
	Std.	1.00	0.99	0.99	0.99
	Opt.	N/A	N/A	1.00	N/A
75' [22.86]	Opt.	0.98	0.96	0.94	0.96
	Std.	0.99	0.98	0.98	0.99
	Opt.	N/A	N/A	1.00	N/A
100' [30.48]	Opt.	0.97	0.94	0.92	0.95
	Std.	N/A	N/A	0.98	0.98
	Opt.	N/A	N/A	N/A	N/A
125' [38.10]	Opt.	0.97	0.93	0.90	0.94
	Std.	N/A	N/A	0.97	0.97
	Opt.	N/A	N/A	N/A	N/A
150' [45.72]	Opt.	0.96	0.92	0.88	0.93
	Std.	N/A	N/A	0.96	0.97
	Opt.	N/A	N/A	N/A	N/A

NOTES:

1. Do **NOT** exceed the limits in the liquid and suction line sizing charts.
2. Do **NOT** use 7/8 OD suction lines in 2 or 3-ton applications.
3. Do **NOT** use 1-1/8 OD suction line in ANY application.
4. 2 and 3-ton line sets over 75 feet **MUST** use the optional suction line.

Refer to Line Size Information in Tables 3, 4 and 5 for correct size and multipliers to be used to determine capacity for various vapor line diameters and lengths of run. The losses due to the lines being exposed to outdoor conditions are not included.

The factory refrigeration charge in the outdoor unit is sufficient for 15 feet of interconnecting lines. The factory refrigeration charge in the outdoor unit is sufficient for the unit and 15 feet of standard size interconnecting liquid and vapor lines. For different lengths, adjust the charge as indicated below.

1/4" ± .3 oz. per foot

5/16" ± .4 oz. per foot

3/8" ± .6 oz. per foot

1/2" ± 1.2 oz. per foot

7.2 Maximum Length of Lines

The maximum length of interconnecting line is 150 feet. Always use the shortest length possible with a minimum number of bends. Additional compressor oil is not required for any length up to 150 feet.

NOTE: Excessively long refrigerant lines cause loss of equipment capacity.

7.3 Outdoor Unit Installed Above or Below Indoor Coil

Use the following guidelines when installing the unit:

1. Expansion Valve Coil:
 - a. The vertical separation cannot exceed the value in Tables 4 and 5.
 - b. No changes are required for expansion valve coils.
2. It is recommended to use the smallest liquid line size permitted to minimize the system charge.
3. Tables 4 and 5 may be used for sizing horizontal runs.

TABLE 4

(-)ARL LIQUID LINE SIZING

LIQUID LINE SIZE - OUTDOOR UNIT ABOVE INDOOR COIL

R-410A System Capacity Model	Line Size Connection Size (Inch I.D.) [mm]	Line Size (Inch O.D.) [mm]	Liquid Line Size Outdoor Unit Above Indoor Coil (Cooling Only - Does not apply to Heat Pumps) Total Equivalent Length - Feet [m]					
			25 [7.62]	50 [15.24]	75 [22.86]	100 [30.48]	125 [38.1]	150 [45.72]
			Minimum Vertical Separation - Feet [m]					
-024	3/8" [9.53]	1/4" [6.35]	0	1 [0.31]	24 [7.32]	50 [15.24]	76 [23.17]	102 [31.09]
		5/16" [7.93]*	0	0	0	0	0	
		3/8" [9.52]	0	0	0	0	0	
-036	3/8" [9.53]	5/16" [7.93]	0	0	0	5 [1.52]	13 [3.96]	20 [6.10]
		3/8" [9.52]*	0	0	0	0	0	
		1/2" [12.70]	0	0	0	0	0	
-048	3/8" [9.53]	5/16" [7.93]	0	0	0	7 [2.13]	28 [8.53]	50 [15.24]
		3/8" [9.52]*	0	0	0	0	0	
		1/2" [12.70]	0	0	0	0	0	
-060	3/8" [9.53]	3/8" [9.52]*	0	0	0	0	0	0
		1/2" [12.70]	0	0	0	0	0	0

NOTES: N/A = Application Not Recommended

*Standard Line Size

LIQUID LINE SIZE - OUTDOOR UNIT BELOW INDOOR COIL

R-410A System Capacity Model	Line Size Connection Size (Inch I.D.) [mm]	Line Size (Inch O.D.) [mm]	Liquid Line Size Outdoor Unit Below Indoor Coil (Cooling Only - Does not apply to Heat Pumps) Total Equivalent Length - Feet [m]					
			25 [7.62]	50 [15.24]	75 [22.86]	100 [30.48]	125 [38.1]	150 [45.72]
			Maximum Vertical Separation - Feet [m]					
-024	3/8" [9.53]	1/4" [6.35]	13 [3.96]	N/A	N/A	N/A	N/A	N/A
		5/16" [7.93]*	25 [7.62]	21 [6.40]	17 [5.18]	13 [3.96]	9 [2.74]	N/A
		3/8" [9.52]	25 [8.23]	26 [7.93]	25 [7.62]	23 [7.01]	22 [6.71]	20 [6.10]
-036	3/8" [9.53]	5/16" [7.93]	15 [4.57]	N/A	N/A	N/A	N/A	N/A
		3/8" [9.52]*	19 [5.79]	17 [5.18]	15 [4.57]	12 [3.66]	10 [3.05]	N/A
		1/2" [12.70]	21 [6.40]	21 [6.40]	20 [6.10]	20 [6.10]	19 [5.79]	19 [5.79]
-048	3/8" [9.53]	5/16" [7.93]	25 [9.14]	17 [5.18]	N/A	N/A	N/A	N/A
		3/8" [9.52]*	25 [11.89]	34 [10.36]	30 [9.14]	25 [7.62]	21 [6.40]	17 [5.18]
		1/2" [12.70]	25 [12.80]	41 [12.50]	41 [12.50]	40 [12.19]	39 [11.89]	38 [11.58]
-060	3/8" [9.53]	3/8" [9.52]*	25 [17.98]	49 [14.94]	40 [12.19]	30 [9.14]	20 [6.10]	10 [3.05]
		1/2" [12.70]	25 [19.51]	50 [18.90]	61 [18.59]	60 [18.29]	59 [17.98]	57 [17.37]

NOTES: N/A = Application Not Recommended

*Standard Line Size

7.4 Tubing Installation

Observe the following when installing correctly sized type "L" refrigerant tubing between the condensing unit and evaporator coil:

- If a portion of the liquid line passes through a hot area where liquid refrigerant can be heated to form vapor, insulating the liquid line is required.
- Use clean, dehydrated, sealed refrigeration grade tubing.
- Always keep tubing sealed until tubing is in place and connections are to be made.
- Blow out the liquid and vapor lines with dry nitrogen before connecting to the outdoor unit and indoor coil. Any debris in the line set will end up plugging the expansion device.
- As an added precaution, a high quality filter drier is standard on R-410A units.
- Do not allow the vapor line and liquid line to be in contact with each other. This causes an undesirable heat transfer resulting in capacity loss and increased power consumption. The vapor line must be insulated.

TABLE 5
(-)ARL SUCTION LINE SIZING

SUCTION LINE SIZE - OUTDOOR UNIT ABOVE INDOOR COIL

R-410A System Capacity Model	Line Size Connection Size (Inch I.D.) [mm]	Line Size (Inch O.D.) [mm]	Suction Line Size					
			Outdoor Unit ABOVE Indoor Coil (Cooling Only - Does not apply to Heat Pumps)					
			Total Equivalent Length - Feet [m]					
			25 [7.62]	50 [15.24]	75 [22.86]	100 [30.48]	125 [38.1]	150 [45.72]
-024	3/4" [19.05]	5/8" [15.88]	Same as Liquid Line Size Table					
		3/4" [19.05]*	N/A					
		7/8" [22.23]	N/A					
-036	3/4" [19.05]	5/8" [15.88]	Same as Liquid Line Size Table					
		3/4" [19.05]*	N/A					
		7/8" [22.23]	N/A					
-048	7/8" [22.22]	5/8" [15.88]	Same as Liquid Line Size Table					
		3/4" [19.05]	Same as Liquid Line Size Table					
		7/8" [22.23]*	Same as Liquid Line Size Table					
-060	7/8" [22.22]	3/4" [19.05]	Same as Liquid Line Size Table					
		7/8" [22.23]*	Same as Liquid Line Size Table					
		1-1/8" [28.58]	N/A					

NOTES: Using suction line larger than shown in chart will result in poor oil return.
N/A = Application Not Recommended
*Standard Line Size

SUCTION LINE SIZE - OUTDOOR UNIT BELOW INDOOR COIL

R-410A System Capacity Model	Line Size Connection Size (Inch I.D.) [mm]	Line Size (Inch O.D.) [mm]	Suction Line Size					
			Outdoor Unit BELOW Indoor Coil (Cooling Only - Does not apply to Heat Pumps)					
			Total Equivalent Length - Feet [m]					
			25 [7.62]	50 [15.24]	75 [22.86]	100 [30.48]	125 [38.1]	150 [45.72]
-024	3/4" [19.05]	5/8" [15.88]	Same as Liquid Line Size Table					
		3/4" [19.05]*	Same as Liquid Line Size Table			N/A		
		7/8" [22.23]	N/A					
-036	3/4" [19.05]	5/8" [15.88]	Same as Liquid Line Size Table					
		3/4" [19.05]*	Same as Liquid Line Size Table					
		7/8" [22.23]	N/A					
-048	7/8" [22.22]	5/8" [15.88]	Same as Liquid Line Size Table					
		3/4" [19.05]	Same as Liquid Line Size Table					
		7/8" [22.23]*	Same as Liquid Line Size Table					
-060	7/8" [22.22]	3/4" [19.05]	Same as Liquid Line Size Table					
		7/8" [22.23]*	Same as Liquid Line Size Table					
		1-1/8" [28.58]	N/A					

NOTES: Using suction line larger than shown in chart will result in poor oil return.
N/A = Application Not Recommended
*Standard Line Size

- If tubing has been cut, make sure ends are deburred while holding in a position to prevent chips from falling into tubing. Burrs such as those caused by tubing cutters can affect performance dramatically, particularly on small liquid line sizes.
- For best operation, keep tubing run as short as possible with a minimum number of elbows or bends.
- Locations where the tubing will be exposed to mechanical damage should be avoided. If it is necessary to use such locations, the copper tubing should be housed to prevent damage.
- If tubing is to be run underground, it must be run in a sealed watertight chase.
- Use care in routing tubing and do not kink or twist. Use a good tubing bender on the vapor line to prevent kinking.
- Route the tubing using temporary hangers, then straighten the tubing and install permanent hangers. Line must be adequately supported.

- The vapor line must be insulated to prevent dripping (sweating) and prevent performance losses. Armaflex and Rubatex are satisfactory insulations for this purpose. Use 1/2" minimum insulation thickness, additional insulation may be required for long runs.
- Check Table 3 for the correct vapor line size. Check Table 4 for the correct liquid line size.

7.5 Tubing Connections

Indoor coils have only a holding charge of dry nitrogen. Keep all tube ends sealed until connections are to be made.

- Use type "L" copper refrigeration tubing. Braze the connections with the following alloys:
 - copper to copper - 5%
 - Silver alloy (no flux)
 - copper to steel or brass - 35%
 - silver alloy (with flux)
- Be certain both refrigerant shutoff valves at the outdoor unit are closed.
- Clean the inside of the fittings and outside of the tubing with steel wool or sand cloth before soldering. Always keep chips, steel wool, dirt, etc., out of the inside when cleaning.
- Assemble tubing part way into fitting. Apply flux all around the outside of the tubing and push tubing into stop. This procedure will keep the flux from getting inside the system.
- Remove the cap and schrader core from service port to protect seals from heat damage.
- Use an appropriate heatsink material around the copper stub and the service valves before applying heat.
- **IMPORTANT:** Do not braze any fitting with the TEV sensing bulb attached.
- Braze the tubing between the outdoor unit and indoor coil. Flow dry nitrogen into a service port and through the tubing while brazing.
- After brazing – use an appropriate heatsink material to cool the joint and remove any flux residue.
- The service valves are not backseating valves. To open the valves, remove the valve cap with an adjustable wrench. Insert a 3/16" or 5/16" hex wrench into the stem. Back out counterclockwise.
- Replace the valve cap finger tight then tighten an additional 1/2 hex flat for a metal-to-metal seal.

7.6 Leak Testing

- Pressurize line set and coil through service fittings with dry nitrogen to 150 PSIG maximum. Leak test all joints using liquid detergent. If a leak is found, recover pressure and repair.

WARNING

DO NOT USE OXYGEN TO PURGE LINES OR PRESSURIZE SYSTEM FOR LEAK TEST. OXYGEN REACTS VIOLENTLY WITH OIL, WHICH CAN CAUSE AN EXPLOSION RESULTING IN SEVERE PERSONAL INJURY OR DEATH.

8.0 COMPRESSOR CRANKCASE HEAT (CCH)

CCH is standard on these models due to refrigerant migration during the off cycle that can result in a noisy start up.

Crankcase Heater Operation:

Supplemental Crankcase heat is required to prevent refrigerant migration in systems with relatively high system refrigerant charges.

The crankcase heater control is integrated into the *Comfort Control*² and is designed for maximum energy savings.

Summary of operation:

- The crankcase heater is off whenever the compressor is running.

- Once the compressor turns off, the crankcase heater control (CCH) begins the two-hour timer countdown.
 - If the compressor stays off for two hours, the CCH turns on the crankcase heater.
- All heaters are located on the lower half of the compressor shell. Its purpose is to drive refrigerant from the compressor shell during long off cycles, thus preventing damage to the compressor during start-up.

At initial start-up or after extended shutdown periods, make sure the heater is energized for at least 12 hours before the compressor is started. (Disconnect switch on and wall thermostat off.)

9.0 HARD START COMPONENTS

Factory-installed start components are standard on all models.

10.0 HIGH AND LOW PRESSURE CONTROLS (HPC AND LPC)

These controls keep the compressor from operating in pressure ranges which can cause damage to the compressor. Both controls are in the low voltage control circuit.

High pressure control (HPC) is an automatic-reset which opens near 610 PSIG and closes near 420 PSIG.

The low pressure control (LPC) is an automatic-reset which opens near 15 PSIG and closes near 40 PSIG.

NOTE: HPC and LPC are monitored by the *Comfort Control*². See Section 12.0.

CAUTION

THE COMPRESSOR HAS AN INTERNAL OVERLOAD PROTECTOR. UNDER SOME CONDITIONS, IT CAN TAKE UP TO 2 HOURS FOR THIS OVERLOAD TO RESET. MAKE SURE OVERLOAD HAS HAD TIME TO RESET BEFORE CONDEMNING THE COMPRESSOR.

10.1 Evacuation Procedure

Evacuation is the most important part of the entire service procedure. The life and efficiency of the equipment is dependent upon the thoroughness exercised by the serviceman when evacuating air and moisture from the system.

Air in the system causes high condensing temperatures and pressure, resulting in increased power input and non-verifiable performance.

Moisture chemically reacts with the refrigerant and oil to form corrosive hydrofluoric and hydrochloric acids. These attack motor windings and parts, causing breakdown.

After the system has been leak checked and proven sealed, connect the vacuum pump and evacuate system to 500 microns. The vacuum pump must be connected to both the high and low sides of the system through adequate connections. Use the largest size connections available since restrictive service connections may lead to false readings because of pressure drop through the fittings.

IMPORTANT: Compressors (especially scroll type) should never be used to evacuate the air conditioning system because internal electrical arcing may result in a damaged or failed compressor.

With thermostat in the "Off" position, turn the power on to the furnace and the heat pump. Start the heat pump and the furnace with the thermostat. Make sure the blower is operating.

11.0 CONDENSING UNITS EQUIPPED WITH THE COMFORT CONTROL² SYSTEM™

Comfort Control² is the next generation of the Integrated Compressor Control (ICC) and is an integral part of the Comfort Control² System™ with the following features:

11.1 Control Description (see Figure 4)

Dual 7-Segment LED

- Displays status and diagnostic codes (See Status and Diagnostic Description)
- Displays diagnostic/fault recall (See Test Mode/Fault Recall)

Red LED (Y1)

- Y1 red LED (solid on) indicates Y1 call from thermostat is present

⚠ CAUTION

UNIT MAY START SUDDENLY AND WITHOUT WARNING
Solid red light indicates a thermostat call for unit operation is present at the ICC control. ICC control will attempt to start unit after short cycle timer expires or when in Active Protection mode will attempt to restart unit prior to Lockout mode.

Line Voltage Connector

- Line voltage is connected to control board at lug terminals L1 & L2
- Maximum wire size accepted is 6 AWG copper wire
- # 4 – 6 AWG 45 in/lbs
- # 8 AWG 40 in/lbs
- # 10 – 14 AWG 35 in/lbs
- (Check wire terminations annually)

Compressor Control (K2)

- Sealed single pole compressor relay switch with optical feedback feature (arc detection)

COMFORT CONTROL² SYSTEM™ CONTROL WIRING

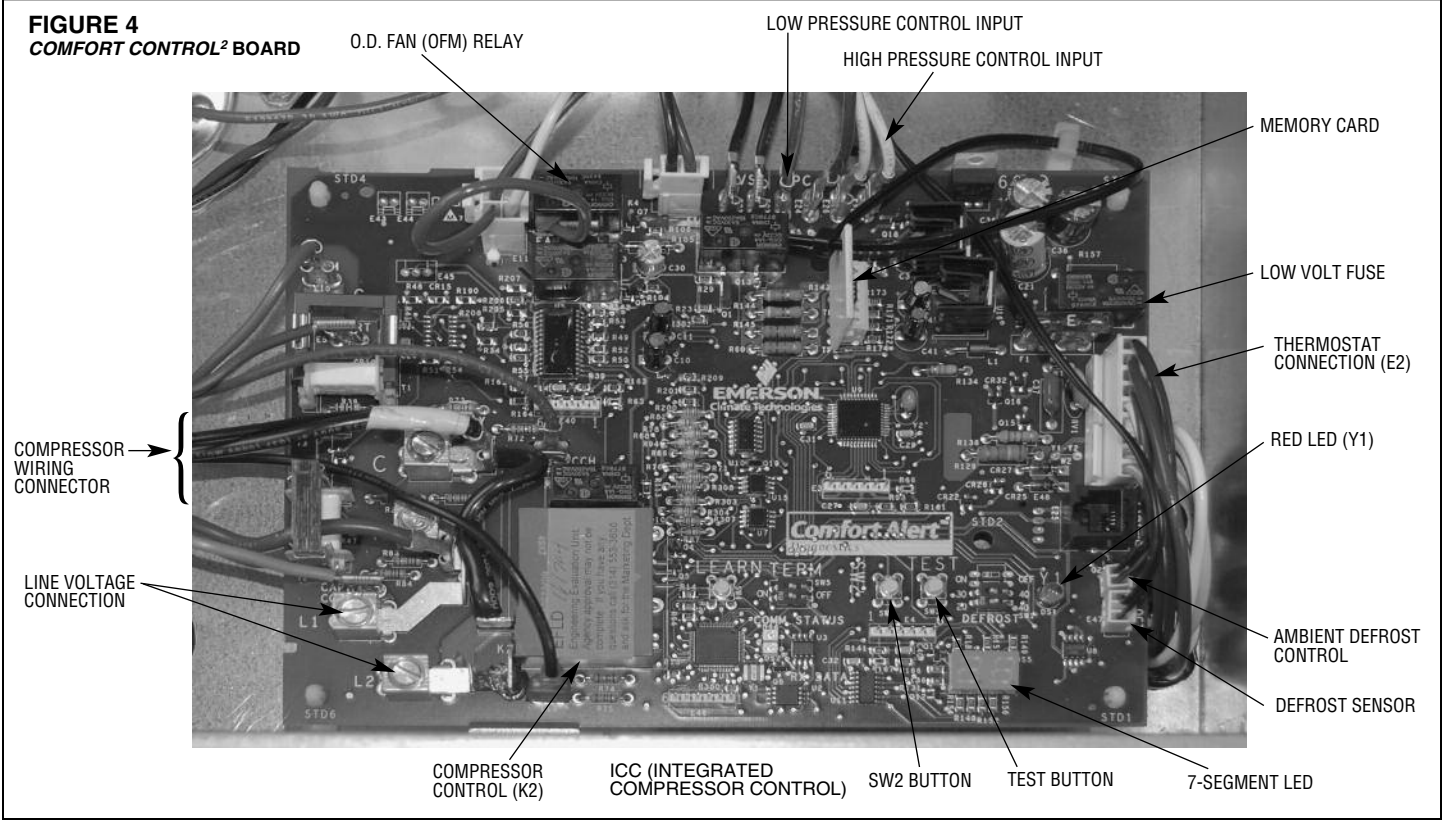

Thermostat Connector (E2)

- **R** – 24VAC from the indoor unit 24VAC transformer (40 VA minimum)
- **C** – 24VAC Common from the indoor unit 24VAC transformer
- 1-Data: System Communications Line 1
- 2-Data: System Communications Line 2

Low Volt Fuse

- If required replace with 3 A automotive ATC style blade fuse

Low Pressure Control (LPC Input)

- Low-pressure control is factory installed
- Low pressure control is an automatic resetting device

High Pressure Control (HPC Input)

- High-pressure control is factory installed
- High pressure control is an automatic resetting device

Ambient Temperature Sensor (included with all applications)

- Included with all applications

TEST and SW2 Buttons

- TEST and SW2 buttons used to enter Test and Fault Recall Mode

Memory Card

- The memory card stores all unit information.
- The unit information is called shared data.
- The shared data is all the information needed for proper unit operation.

11.2 Comfort Control² System™ Control Wiring

The *Comfort Control² System™* consists of:

- Serial communicating heat pump or condensing unit equipped with the *Comfort Control² System™*
- Air handler or furnace equipped with the *Comfort Control² System™*
- *Comfort Control²* thermostat

IMPORTANT: If the installed system does not meet these requirements, the system must be wired using traditional control wiring, reference Section 11.7 Conventional 24VAC Thermostat Control Wiring.

The *Comfort Control² System™* requires four (4) control wires for unit operation:

- R – 24VAC
- C – 24VAC common
- 1 – Data wire 1
- 2 – Data wire 2

Note: *Comfort Control² System™* requires 18 AWG thermostat wire.

Note: Term dip switches should be in “ON” position.

If the low voltage control wiring is run in conduit with the power supply, Class I insulation is required. Class II insulation is required if run separate. Low voltage wiring may be run through the insulated bushing provided in the 7/8 hole in the base panel, up to and attached to the pigtails from the bottom of the control box. Conduit can be run to the base panel if desired by removing the insulated bushing.

The *Comfort Control²* air handler or *Comfort Control²* furnace transformer is equipped with a 24 volt, 50 VA transformer for proper system operation. See the wiring diagram in Figure 5 for reference. Use Table 5 to size the 24-volt control wiring.

The four 18AWG low voltage control wires must be installed from the thermostat to the indoor unit and from indoor unit to the outdoor unit. The wire length between the thermostat and indoor unit should not be greater than 100 feet. The wire length between the indoor unit and outdoor unit should not be greater than 125 feet.

11.3 Comfort Control² System™ ICC Control Operation

Installation Verification

- 24V AC power on R&C must be present at the ICC for it to operate

FIGURE 5
TYPICAL COMFORT CONTROL² SYSTEM™ WIRING DIAGRAM

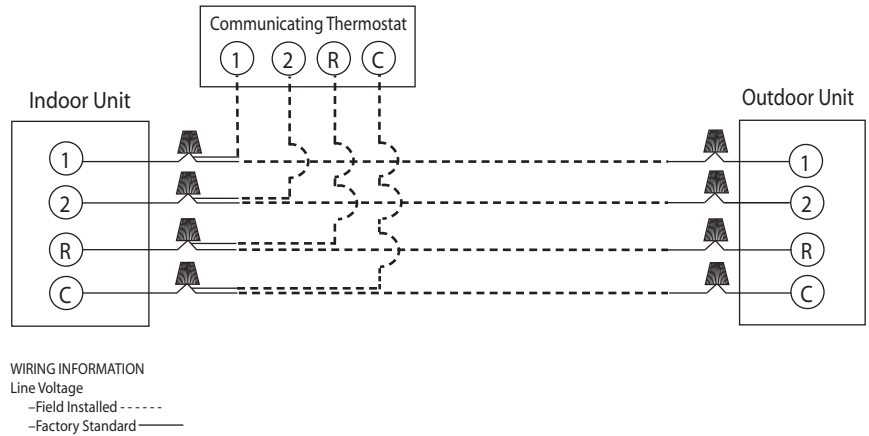

- Line voltage must be present at the ICC for the compressor and the outdoor fan to operate
- The ICC displays a “0” for standby mode. Standby mode indicates line voltage and 24VAC are present at the ICC and there is not a command for unit operation from the *Comfort Control²* thermostat.



Zero (0) displayed
The unit is in standby

Command for Compressor Operation (Y1 LED)

- If a command for compressor operation is received by the ICC (first stage/second stage cooling or first stage/second stage heating), the red Y1 LED will illuminate.
- The ICC has an on/off fan delay of one (1) second for each stage of heating or cooling.
- The ICC ignores the low pressure control for the first 90 seconds of compressor operation.
- The dual 7-segment LED displays five (5) operational status codes.

1) First Stage Cooling Operation – When the ICC receives a command for first stage cooling operation, a lower case “c” is displayed on the dual 7-segment LEDs.



Lower case “c” indicates first stage cooling operation

2) Second Stage Cooling Operation – When the ICC receives a command for second stage cooling operation, an upper case “C” is displayed on the dual 7-segment LEDs.



Upper case “C” indicates second stage cooling operation

3-minute Anti-short Cycle Timer

- The ICC has a built in 3-minute time delay between compressor operations to protect the compressor against short cycling. The dual 7-segment LEDs will flash “c” or “C” while the short cycle timer is active and a command for unit operation is received.



Flashing lower case c
A command for first stage cooling has been received



Flashing upper case C
A command for second stage cooling has been received

- The 3-minute time delay can be bypassed when a command for compressor operation is present by pressing the TEST button for 1 second and releasing. The compressor will begin operation and the dual 7-segment will stop flashing.

30 Second Minimum Run Timer

- The ICC has a built in 30 second minimum unit run time. If a command for compressor operation is received by the ICC and the command is removed, the compressor will continue to operate for 30 seconds. The dual 7-segment LEDs will flash “c” or “C” while the minimum run timer is active.

1 Second Compressor/Fan Delay

- The ICC starts/stops the outdoor fan one (1) second after the start/stop of the compressor upon a command for compressor operation to minimize current inrush and/or voltage drop.

11.4 Active Compressor Protection Mode

- The ICC actively protects the compressor from harmful operation during a fault condition.
- When the ICC detects a condition that could damage the compressor, the ICC will enter active protection mode and lockout compressor operation
- The condition causing active protection must be resolved then the ICC can be reset to restart the system.
- There are five (5) active protection modes:

1) Low Pressure Control Lockout

- The ICC will display a flashing “L” followed by a flashing 21 when a low pressure control lockout occurs.
- The ICC addresses low pressure control faults differently depending on the mode of unit operation (cooling or heating mode).

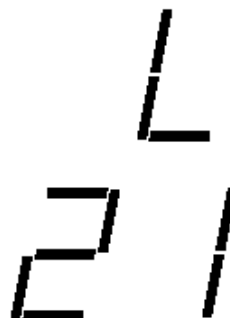

Active Protection – Code L21 – Open low pressure control

Cooling Mode

- If the LPC opens three (3) times during the same command for cooling operation, the ICC will lockout the compressor to keep it from continuing to operate and flash a “L” on the dual 7-segment LEDs followed by a “21”.

IMPORTANT: This mode of active protection must be manually reset.

2) High Pressure Control Lockout

- If the HPC opens three (3) times during the same command for unit operation, the ICC will lockout the compressor to keep it from continuing to operate and flash a “L” on the dual 7-segment LEDs followed by a “29”.

Active Protection – Code L29 – Open high pressure control

IMPORTANT: This mode of active protection must be manually reset.

3) Locked Rotor

- The ICC will display a flashing “L” followed by a flashing “04” when a locked rotor condition occurs.

Active Protection – Code L4 – Locked rotor

If the ICC detects the compressor has run less than 15 seconds for four (4) consecutive starts during the same command for unit operation, the ICC will lockout the compressor to keep it from continuing to operate and flash a “L” on the dual 7-segment LEDs followed by a “04”.

IMPORTANT: This mode of active protection must be manually reset.

4) Compressor Protector Trip

- If ICC detects a protector trip it will display a “P”. If protector doesn’t reset within 4 hours, the ICC display will change to “5”.

Compressor Protector – Code P – Protector Trip

5) Open Start Circuit Lockout

- The ICC will display a flashing “L” followed by a flashing “06” when an open start circuit condition occurs.

Active Protection – Code L6 – Compressor open start circuit

If the ICC detects current in the run circuit without current present in the start circuit, the ICC will lockout the compressor to keep it from continuing to operate and flash a “L” on the dual 7-segment LEDs followed by a “06”.

IMPORTANT: This mode of active protection must be manually reset.

6) Open Run Circuit Lockout

- The ICC will display a flashing “L” followed by a flashing “07” when an open start circuit condition occurs.

Active Protection – Code L7 – Compressor open run circuit

If the ICC detects current in the start circuit without current present in the run circuit, the ICC will lockout the compressor to keep it from continuing to operate and flash a “L” on the dual 7-segment LEDs followed by a “07”.

IMPORTANT: This mode of active protection must be manually reset.

Exiting Active Compressor Protection Lockout

There are three methods to reset the ICC after an active protection lockout:

- 1) Cycle the line voltage to the unit
- 2) Cycle 24VAC to the ICC (remove the R or C connection to the ICC)
- 3) Push the TEST button down with an insulated probe for one (1) second and release

Note: The ICC will attempt to start the unit when the TEST button is pressed and released

Note: The preferred method of resetting the ICC is to push the TEST button down for one (1) second.

11.5 Test and Fault Recall Modes

Test Mode (Test Button on the ICC)

- Enter TEST mode by pressing the TEST button with an insulated probe for one (1) second and release.
- The TEST mode causes the ICC to do the following
 - 1) Resets the ICC from any active protection lockout mode
 - 2) Resets the 3-minute anti-short cycle timer
 - 3) Energizes the unit without a command for unit operation
- If the 3-minute anti-short cycle timer or 30 second minimum run timer is active (a flashing “c” or “C” is displayed on the dual 7-segment LEDs) and a command for unit operation is present, TEST mode causes:
 - 1) A “t” to display momentarily on the dual 7-segment display



Lower case “t”

- 2) The compressor will start and the outdoor fan will operate
- 3) The display will change to a steady “c” or “C” to show the current command for unit operation.

Note: If a command for unit operation is present at the end of TEST mode will cause the unit to continue to operate.

- If no command for unit operation is present, TEST mode causes
 - 1) A steady “t” appears on the dual 7-segment LEDs
 - 2) The compressor will start
 - 3) The compressor will turn off after 5-seconds.

Note: Entering TEST mode without a command for unit operation will cause the compressor to run 5-seconds.

Fault Recall Mode (TEST and SW2 Buttons)

- Enter **FAULT RECALL** mode by pressing the **TEST** and **SW2** buttons at the same time with insulated probes for one (1) second and release.
- When entering and exiting **FAULT RECALL** mode the top and bottom segments of the dual 7-segment LEDs will illuminate.



Fault Recall Mode – the top and bottom segments on the right side are illuminated



- When entering **FAULT RECALL** mode, the ICC will automatically scroll through stored faults on the dual 7-segment LEDs.
- Each fault is displayed one time with the top right-hand segment of the dual 7-segment display activated between faults.
- Each fault is displayed with the most recent fault displayed first.
- A maximum of six individual faults can be stored
- A maximum of three consecutive identical faults are stored.
- A "0" will be displayed with no faults are stored
- The ICC will automatically exit the **FAULT RECALL** mode after displaying stored faults

Clear Fault History (TEST and SW2 Buttons)

- Clear **FAULT HISTORY** by pressing both **TEST** and **SW2** button for five (5) seconds with insulated probes and release.
- The top and bottom segments of the dual 7-segment LEDs flash to indicate the history has been cleared.



 Fault history is cleared with the top and bottom LED segments flash













NOTE: The memory card for the system has specific shared data for this system. The memory card is attached to the control box with a tether. The tether has an identification tag that can be used to identify the memory card. For the system data faults d1 through d8 reference the label on the memory card tether.

**COMFORT CONTROL² SYSTEM™ CONTROL WIRING
AND
CONVENTIONAL THERMOSTAT WIRING
ICC DIAGNOSTIC CODES**

ICC Diagnostic Codes

Descriptions of the ICC diagnostic codes are provided below:

Dual 7-Segment LEDs Display Code	Diagnostic Description	Status/Possible Cause – Troubleshooting Information
	0 – Standby No command for unit operation	Normal operation
	c - First Stage Cooling Unit has received a command for first stage cooling	Normal operation
 FLASHING	c - Anti-short cycle timer (3 minutes) or Minimum run timer (30 seconds) active	<ul style="list-style-type: none"> The unit has received a command for first stage cooling during an active anti-short cycle timer or minimum run timer. Wait until unit timer has expired or press the TEST button to defeat short cycle delay.
	C - Second Stage Cooling Unit has received a command for second stage cooling	Normal operation
 FLASHING	C - Anti-short cycle timer (3 minutes) or Minimum run timer (30 seconds) active	<ul style="list-style-type: none"> The unit has received a command for second stage cooling during an active anti-short cycle timer or minimum run timer. Wait unit timer has expired or press the TEST button to defeat short cycle delay.
	t - Test Mode	The ICC is in TEST mode
	P – Protector Trip A command for compressor operation is present but no current is measured to the compressor	<ul style="list-style-type: none"> Motor protector open Line voltage disconnected
	01 – Long Run Time (Compressor) The compressor has continuously run for more than 18 hours in the cooling mode.	<ul style="list-style-type: none"> Low refrigerant charge Air ducts have substantial leakage Dirty indoor air filter Dirty outdoor coil
	02 – High Side Fault Compressor limit has opened four (4) times within a call for operation	<ul style="list-style-type: none"> Outdoor coil is dirty (cooling mode) Outdoor fan is not running (cooling mode) Dirty indoor coil or filter (heating mode) Indoor blower is not running (heating mode) Liquid line restriction Excessive refrigerant charge
	03 – Short Cycling The ICC detects the run time for the past four (4) compressor cycles is less than three (3) minutes each.	<ul style="list-style-type: none"> Check thermostat wire connections (R, C, 1, & 2) Check thermostat location in zone (too close to discharge grill)
	L4 – Locked Rotor The ICC detects four (4) consecutive protector trips have occurred and the average run time for each trip is less than 15 seconds	<ul style="list-style-type: none"> Bad run capacitor Low line voltage Excessive refrigerant in compressor Seized bearings in compressor

Dual 7-Segment LEDs Display Code	Diagnostic Description	Status/Possible Cause – Troubleshooting Information
05	05 – Open circuit (Compressor will not Run) <ul style="list-style-type: none"> The ICC has had a protector trip for longer than 4 hours 	<ul style="list-style-type: none"> Check for damaged, miswired, or wrong run capacitor Check for broken wires, loose connectors, or miswired compressor Check compressor windings for continuity Check for open compressor internal protector
06	06 – Compressor Open Start Circuit The ICC detects current in the Run circuit but not in the Start circuit of the compressor	<ul style="list-style-type: none"> Check for damaged, miswired, or wrong run capacitor Check for broken wires, loose connectors, or miswired compressor Check compressor windings for continuity
L6	06 – Compressor Open Start Circuit The ICC detects current in the Run circuit but not in the Start circuit of the compressor four (4) times in one compressor call	<ul style="list-style-type: none"> Check for damaged, miswired, or wrong run capacitor Check for broken wires, loose connectors, or miswired compressor Check compressor windings for continuity
07	07 – Compressor Open Run Circuit The ICC detects current in the Start circuit but not in the Run circuit of the compressor	<ul style="list-style-type: none"> Check for damaged, miswired, or wrong run capacitor Check for broken wires, loose connectors, or miswired compressor Check compressor windings for continuity
L7	07 – Compressor Open Run Circuit The ICC detects current in the Start circuit but not in the Run circuit of the compressor four (4) times in one compressor call	<ul style="list-style-type: none"> Check for damaged, miswired, or wrong run capacitor Check for broken wires, loose connectors, or miswired compressor Check compressor windings for continuity
09	09 – Low Secondary Volts The secondary voltage at R and C is below 18VAC	<ul style="list-style-type: none"> Control transformer overloaded Low line voltage
21	21 – Low Pressure Control Open The ICC detects the LPC is open. Note: The low pressure control is ignored for the first 90 seconds of compressor operation	<ul style="list-style-type: none"> Unit has low refrigerant charge Indoor coil is frozen (cooling mode) Dirty indoor coil or filter (cooling mode) Indoor blower is not running (cooling mode) Outdoor coil is frozen (heating mode) Expansion valve is not operating correctly
L 21 FLASHING	L21 – Active Protection Low Pressure Control Trip	LPC has opened 3 times in the same cooling operation, the ICC has locked out the compressor to protect it. ICC alternately flashes L and 21
27	27 – Low Line Voltage or No Line Voltage Fault	<ul style="list-style-type: none"> Check incoming line voltage to the disconnect and unit Check wiring connections
28	28 – High Line Voltage Fault	<ul style="list-style-type: none"> Check line voltage

Dual 7-Segment LEDs Display Code	Diagnostic Description	Status/Possible Cause – Troubleshooting Information
29	29 – High Pressure Control Open The ICC detects the HPC is open	<ul style="list-style-type: none"> • Outdoor coil is dirty (cooling mode) • Outdoor fan is not running (cooling mode) • Dirty indoor coil or filter (heating mode) • Indoor blower is not running (heating mode) • Liquid line restriction • Excessive refrigerant charge
L 29 FLASHING	L29 – Active Protection High Pressure Control Trip	LPC has opened 3 times in the same cooling operation, the ICC has locked out the compressor to protect it. ICC alternately flashes L and 29
30	30 – Fuse Open The ICC detects the on-board fuse is open	<ul style="list-style-type: none"> • The 3-amp fuse on the ICC is open. • Low voltage wiring at R and C is damaged or miswired.
80	80 – Low Air Flow The ICC detects that the indoor unit is not providing the minimum airflow requirements.	<ul style="list-style-type: none"> • Misapplied/wrong indoor air mover – replace with properly sized unit.
83	83 – Condenser Coil Temperature Fault The sensor detects an abnormally low or high coil temperature	<ul style="list-style-type: none"> • Replace the sensor • Check sensor is installed correctly on control
84	84 – Outdoor Ambient Temperature Fault The sensor detects an abnormally low or high outdoor ambient temperature	<ul style="list-style-type: none"> • Check unit placement – If the outdoor unit is in a high temperature area, wait until the ambient temperature drops and check sensor reading. • Replace the sensor. • Check sensor is installed correctly on control
93	93 – Internal Control Fault The control is not functioning properly.	<ul style="list-style-type: none"> • Check control for proper system operation. • Replace control
d1	d1 – No Shared Data	<ul style="list-style-type: none"> • Replace memory card with correct system information.
d3	d3 – Airflow CFM Mismatch The indoor air mover (air handler/furnace) cannot supply the required airflow for proper system operation	<ul style="list-style-type: none"> • Misapplied/wrong indoor air mover – replace with properly sized air handler/furnace.
d4	d4 – (Device) Memory Card Invalid for Device The data in the memory card inserted into the control board does not match the data in the control.	<ul style="list-style-type: none"> • Check memory card to ensure it matches device • Check if memory card is present
d8	d8 – Old Shared Data System data is obsolete	<ul style="list-style-type: none"> • If system will not operate, order new memory card to update system information.

11.7 Conventional 24VAC Thermostat Control Wiring

The (-)ARL series of heat pumps allow the installer to use conventional 24VAC control wiring and a conventional thermostat for proper unit operation.

IMPORTANT: The preferred method of unit installation and operation is with the *Comfort Control² System™*. The *Comfort Control² System™* allows access to the fault history of the system. This diagnostic information is not available when the (-)ARL unit is using a conventional thermostat. Reference section 11.2 *Comfort Control² System™* Control Wiring.

Thermostat control wiring requires a minimum of four (4) wires for proper unit operation:

- R – 24VAC
- C – 24VAC common
- Y1 – First stage operation
- Y2 – Second stage operation

Optional wiring:

- L – ICC fault information

L Terminal Output

- Flash 1 – Compressor running extremely long run cycle or low pressure
- Flash 2 – High pressure control trip
- Flash 3 – Unit short cycling
- Flash 4 – Locked rotor
- Flash 5 – Compressor will not run, open circuit
- Flash 6 – Open start circuit
- Flash 7 – Open run circuit
- Flash 8 – Control mis-operation
- Flash 9 – Low control voltage

When the L terminal from the outdoor unit is connected to a conventional thermostat that is L terminal compatible, the thermostat display will flash the above codes.

If the low voltage control wiring is run in conduit with the power supply, Class I insulation is required. Class II insulation is required if run separate. Low voltage wiring may be run through the insulated bushing provided in the 7/8 hole in the base panel, up to and attached to the pigtails from the bottom of the control box. Conduit can be run to the base panel if desired by removing the insulated bushing.

A thermostat and a 24-volt, 40VA minimum transformer are required for the control circuit of the condensing unit. The furnace or the air handler transformer may be used if sufficient. See the wiring diagram for reference. Use Table 6 to size the 24-volt control wirings.

TABLE 6
FIELD WIRE SIZE FOR 24 VOLT THERMOSTAT CIRCUITS

Thermostat Load - Amps	SOLID COPPER WIRE - AWG.					
	3.0	16	14	12	10	10
2.5	16	14	12	12	10	10
2.0	18	16	14	12	12	10
	50	100	150	200	250	300
	Length of Run - Feet (1)					

(1) Wire length equals twice the run distance.

NOTE: Do not use control wiring smaller than No. 18 AWG between thermostat and outdoor unit.

11.8 Typical Non-Communicating Thermostat Wiring Diagrams

The following figures show the typical wiring diagrams with (-)HPN air handler and (-)ARL condensing unit. Cooling and heat pump airflows may need to be adjusted for homeowner comfort once the system is operational.

WIRE COLOR CODE			
BK - BLACK	G - GREEN	PR - PURPLE	Y - YELLOW
BR - BROWN	GY - GRAY	R - RED	
BL - BLUE	O - ORANGE	W - WHITE	

CONVENTIONAL THERMOSTAT WIRING

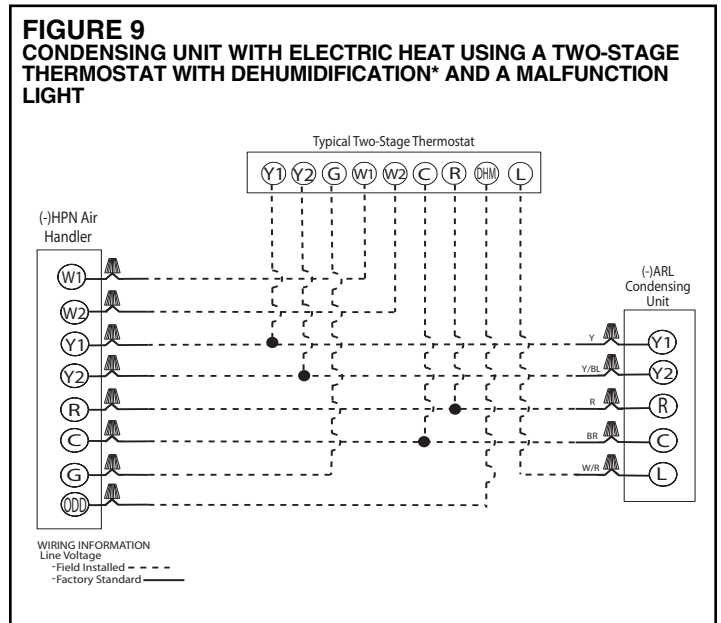
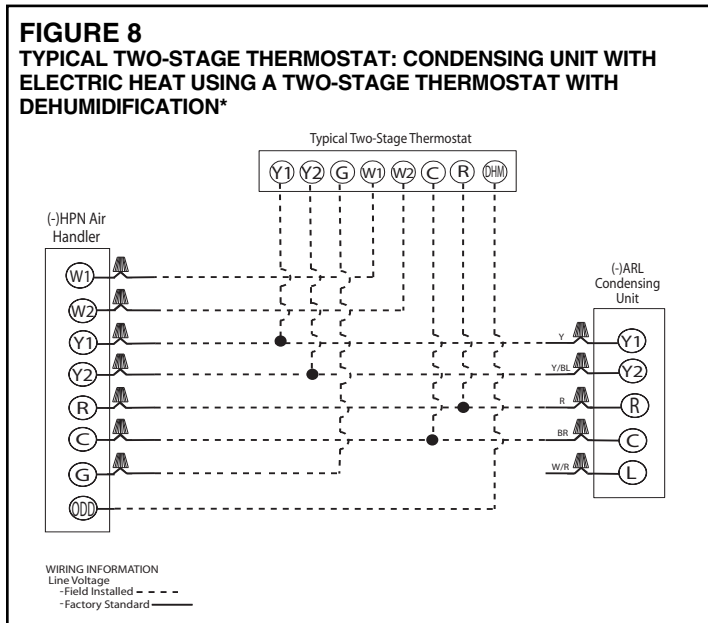
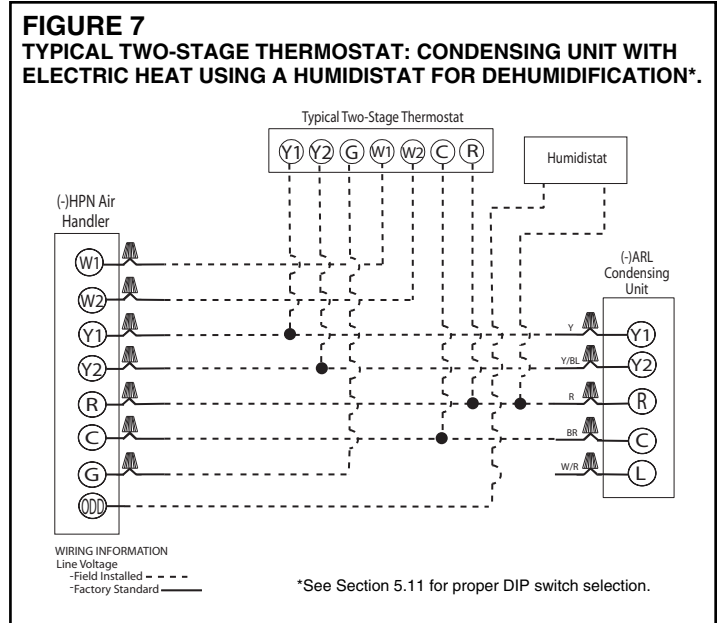
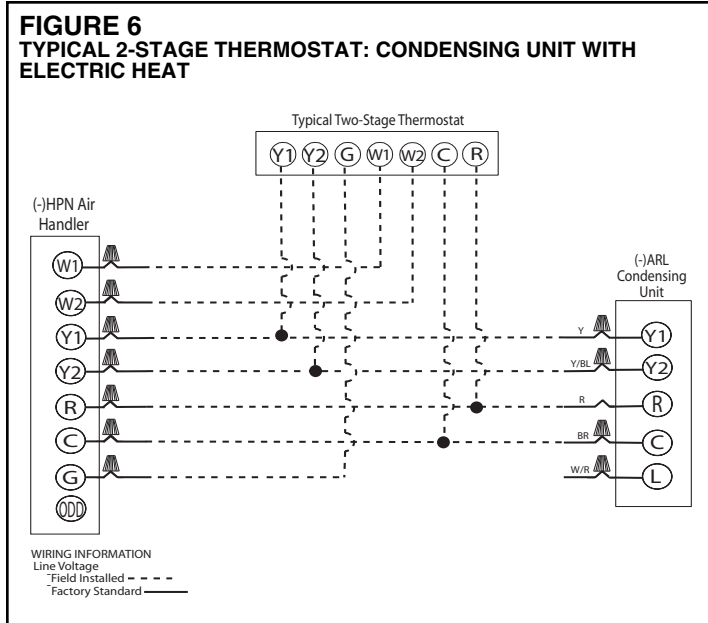

11.9 ICC Control Operation with Conventional Thermostat Wiring

Installation Verification

- 24V AC power on R&C must be present at the ICC for it to operate
- Line voltage must be present at the ICC for the compressor and the outdoor fan to operate
- The ICC displays a “0” for standby mode. Standby mode indicates line voltage and 24VAC are present at the ICC and there is not a call for unit operation from the thermostat.



Zero (0) displayed
The unit is in standby

Call for Compressor Operation (Y1 LED)

- If a call for compressor operation is received by the ICC (first stage/second stage cooling or first stage/second stage heating), the red Y1 LED will illuminate.
- The ICC has an on/off fan delay of one (1) second for each stage of heating or cooling.
- The ICC ignores the lower pressure control for the first 90 seconds of compressor operation.
- On heat pumps, the ICC ignores the LPC during the defrost cycle.
- The dual 7-segment LED displays five (5) operational status codes.

- 1) **First Stage Cooling Operation** – When the ICC receives a call for first stage cooling operation, a lower case “c” is displayed on the dual 7-segment LEDs.



Lower case “c” indicates first stage cooling operation

- 2) **Second Stage Cooling Operation** – When the ICC receives a call for second stage cooling operation, an upper case “C” is displayed on the dual 7-segment LEDs.



Upper case “C” indicates second stage cooling operation

3-minute Anti-short Cycle Timer

- The ICC has a built in 3-minute time delay between compressor operations to protect the compressor against short cycling. The dual 7-segment LEDs will flash “c” or “C” while the short cycle timer is active and a call for unit operation is received.



Flashing lower case c
A call for first stage cooling has been received



Flashing upper case C
A call for second stage cooling has be received

- The 3-minute time delay can be bypassed when a call for compressor operation is present by pressing the TEST button for 1 second and releasing. The compressor will begin operation and the dual 7-segment will stop flashing.

30 Second Minimum Run Timer

- The ICC has a built in 30 second minimum unit run time. If a call for compressor operation is received by the ICC and the call is removed, the compressor will continue to operate for 30 seconds. The dual 7-segment LEDs will flash “c” or “C” while the minimum run timer is active.

1 Second Compressor/Fan Delay

- The ICC starts/stops the outdoor fan one (1) second after the start/stop of the compressor upon a call for compressor operation to minimize current inrush and/or voltage drop.

11.10 Active Compressor Protection Mode

- The ICC actively protects the compressor from harmful operation during a fault condition.
- When the ICC detects a condition that could damage the compressor, the ICC will enter active protection mode and lockout compressor operation
- The condition causing active protection must be resolved then the ICC can be reset to restart the system.
- There are five (5) active protection modes:

1) Low Pressure Control Lockout

- The ICC will display a flashing “L” followed by a flashing 21 when a low pressure control lockout occurs.
- The ICC addresses low pressure control faults differently depending on the mode of unit operation (cooling or heating mode).



Active Protection – Code L21 – Open low pressure control

Cooling Mode

- If the LPC opens three (3) times during the same call for cooling operation, the ICC will lockout the compressor to keep it from continuing to operate and flash a “L” on the dual 7-segment LEDs followed by a “21”.

IMPORTANT: This mode of active protection must be manually reset.

2) High Pressure Control Lockout

- If the HPC opens three (3) times during the same call for unit operation, the ICC will lockout the compressor to keep it from continuing to operate and flash a “L” on the dual 7-segment LEDs followed by a “29”.

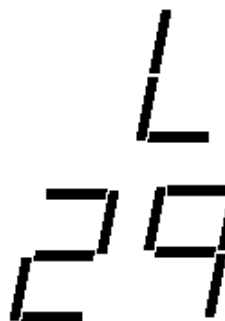

Active Protection – Code L29 – Open high pressure control

IMPORTANT: This mode of active protection must be manually reset.

3) Locked Rotor

- The ICC will display a flashing “L” followed by a flashing “04” when a locked rotor condition occurs.



Active Protection – Code L4 – Locked rotor

If the ICC detects the compressor has run less than 15 seconds for four (4) consecutive starts during the same call for unit operation, the ICC will lockout the compressor to keep it from continuing to operate and flash a “L” on the dual 7-segment LEDs followed by a “04”.

IMPORTANT: This mode of active protection must be manually reset.

4) Open Start Circuit Lockout

- The ICC will display a flashing “L” followed by a flashing “06” when an open start circuit condition occurs.



Active Protection – Code L6 – Compressor open start circuit

If the ICC detects current in the run circuit without current present in the start circuit, the ICC will lockout the compressor to keep it from continuing to operate and flash a “L” on the dual 7-segment LEDs followed by a “06”.

IMPORTANT: This mode of active protection must be manually reset.

5) Open Run Circuit Lockout

- The ICC will display a flashing “L” followed by a flashing “07” when an open start circuit condition occurs.



Active Protection – Code L7 – Compressor open run circuit

If the ICC detects current in the start circuit without current present in the run circuit, the ICC will lockout the compressor to keep it from continuing to operate and flash a “L” on the dual 7-segment LEDs followed by a “07”.

IMPORTANT: This mode of active protection must be manually reset.

Exiting Active Compressor Protection Lockout

There are three methods to reset the ICC after an active protection lockout:

- 1) Cycle the line voltage to the unit
- 2) Cycle 24VAC to the ICC (remove the R or C connection to the ICC)
- 3) Push the TEST button down for one (1) second and release

Note: The ICC will attempt to start the unit when the TEST button is pressed and released

Note: The preferred method of resetting the ICC is to push the TEST button down for one (1) second.

11.11 Test and Fault Recall Modes

Test Mode (Test Button on the ICC)

- Enter TEST mode by pressing the TEST button with an insulated probe for one (1) second and release.
- The TEST mode causes the ICC to do the following
 - 1) Resets the ICC from any active protection lockout mode

- 2) Resets the 3-minute anti-short cycle timer
- 3) Energizes the unit without a call for unit operation
- If the 3-minute anti-short cycle timer or 30 second minimum run timer is active (a flashing “c” or “C” is displayed on the dual 7-segment LEDs) and a call for unit operation is present, TEST mode causes:
 - 1) A “t” to display momentarily on the dual 7-segment display



Lower case “t”

- 2) The compressor will start
- 3) The display will change to a steady “c” or “C” to show the current call for unit operation.

Note: If a call for unit operation is present at the end of TEST mode will cause the unit to continue to operate.

- If no call for unit operation is present, TEST mode causes
 - 1) A steady “t” appears on the dual 7-segment LEDs
 - 2) The compressor will start
 - 3) The compressor will turn off after 5-seconds.

Note: Entering TEST mode without a call for unit operation will cause the compressor to run 5-seconds.

Fault Recall Mode (TEST and SW2 Buttons)

- Enter **FAULT RECALL** mode by pressing the **TEST** and **SW2** buttons at the same time with insulated probes for one (1) second and release.
- When entering and exiting **FAULT RECALL** mode the top and bottom segments of the dual 7-segment LEDs will illuminate.



Fault Recall Mode – the top and bottom segments on the right-hand are illuminated



- When entering **FAULT RECALL** mode, the ICC will automatically scroll through stored faults on the dual 7-segment LEDs.
- Each fault is displayed one time with the top right-hand segment of the dual 7-segment display activated between faults.
- Each fault is displayed with the most recent fault displayed first.
- A maximum of six individual faults can be stored
- A maximum of three consecutive identical faults are stored.
- A “0” will be displayed with no faults are stored
- The ICC will automatically exit the **FAULT RECALL** mode after displaying stored faults

IMPORTANT: The ICC stores the previous two weeks of history faults. The complete stored fault history cannot be displayed using a conventional thermostat.

Clear Fault History (TEST and SW2 Buttons)

- Clear **FAULT HISTORY** by pressing both **TEST** and **SW2** button for five (5) seconds with insulated probes and release.
- The top and bottom segments of the dual 7-segment LEDs flash to indicate the history has been cleared.



Fault history is cleared with the top and bottom LED segments flash



12.0 ELECTRICAL WIRING

Field wiring must comply with the National Electric Code (C.E.C. in Canada) and any applicable local code.

12.1 Power Wiring

It is important that proper electrical power from a commercial utility is available at the condensing unit contactor. Voltage ranges for operation are shown in Table 7.

Install a branch circuit disconnect within sight of the unit and of adequate size to handle the starting current (see Table 1).

Power wiring must be run in a rain-tight conduit. Conduit must be run through the connector panel below the access cover (see Figure 1) and attached to the bottom of the control box.

Connect power wiring to contactor located in outdoor condensing unit electrical box. (See wiring diagram attached to unit access panel.)

Check all electrical connections, including factory wiring within the unit and make sure all connections are tight.

DO NOT connect aluminum field wire to the contactor terminals.

TABLE 7
VOLTAGE RANGES (60 HZ)

Nameplate Voltage	Operating Voltage Range at Copeland Maximum Load Design Conditions for Compressors
208/230 (1 Phase)	197 - 253

12.2 Grounding

A grounding lug is provided near the contactor for a ground wire.

WARNING

THE UNIT MUST BE PERMANENTLY GROUNDED. FAILURE TO DO SO CAN CAUSE ELECTRICAL SHOCK RESULTING IN SEVERE PERSONAL INJURY OR DEATH.

12.3 Control Wiring

If the low voltage control wiring is run in conduit with the power supply, Class I insulation is required. Class II insulation is required if run separate. Low voltage wiring may be run through the insulated bushing provided in the 7/8 hole in the base panel, up to and attached to the pigtails from the bottom of the control box. Conduit can be run to the base panel if desired by removing the insulated bushing.

A thermostat and a 24 volt, 40 VA minimum transformer are required for the control circuit of the condensing unit. The furnace or the air handler transformer may be used if sufficient. See the wiring diagram for reference. Use Table 6 to size the 24 volt control wiring.

13.0 START-UP AND PERFORMANCE

Even though the unit is factory charged with Refrigerant-410A, the charge must be checked to the charge table attached to the service panel and adjusted, if required. Allow a minimum of 5 minutes of run time before analyzing charge.

At initial start-up or after extended shutdown periods, make sure the heater is energized for at least 12 hours before the compressor is started. (Disconnect switch on and wall thermostat off.) Connect the communicating system per Figure 5. Once all devices are connected, power up the line and low voltage to the system. When all devices are powered, the thermostat should detect the indoor and outdoor units within 45 seconds.

14.0 CHECKING AIRFLOW

The air distribution system has the greatest effect on airflow. The duct system is totally controlled by the contractor. For this reason, the contractor should use only industry-recognized procedures.

The correct air quantity is critical to air conditioning systems. Proper operation, efficiency, compressor life, and humidity control depend on the correct balance between indoor load and outdoor unit capacity. Excessive indoor airflow increases the possibility of high humidity problems. Low indoor airflow reduces total capacity, and causes coil icing. Serious harm can be done to the compressor by low airflow, such as that caused by refrigerant flooding.

Heat pump systems require a specified airflow. Each ton of cooling requires between 340 and 450 cubic feet of air per minute (CFM).

Duct design and construction should be carefully done. System performance can be lowered dramatically through bad planning or workmanship.

Air supply diffusers must be selected and located carefully. They must be sized and positioned to deliver treated air along the perimeter of the space. If they are too small for their intended airflow, they become noisy. If they are not located properly, they cause drafts. Return air grilles must be properly sized to carry air back to the blower. If they are too small, they also cause noise.

The installers should balance the air distribution system to ensure proper quiet airflow to all rooms in the home. This ensures a comfortable living space.

These simple mathematical formulas can be used to determine the CFM in a residential or light commercial system.

Electric resistance heaters can use

$$\text{CFM} = \frac{\text{volts} \times \text{amps} \times 3.414}{1.08 \times \text{temp rise}}$$

Gas furnaces can use

$$\text{CFM} = \frac{\text{BTUH}}{\Delta T \times 1.08}$$

An air velocity meter or airflow hood can give a more accurate reading of the system CFM's.

15.0 CHECKING REFRIGERANT CHARGE

Charge for all systems should be checked against the Charging Chart inside the access panel cover. Before using the chart, the indoor conditions must be within 2°F of desired comfort conditions and system must be run until operating conditions stabilize (15 min. to 30 min.)

CAUTION

THE TOP OF THE SCROLL COMPRESSOR SHELL IS HOT. TOUCHING THE COMPRESSOR TOP MAY RESULT IN SERIOUS PERSONAL INJURY.

IMPORTANT: Use industry-approved charging methods to ensure proper system charge.

15.1 Charging Units With R-410A Refrigerant

Charge for all systems should be checked against the Charging Chart inside the access panel cover.

IMPORTANT: Do not operate the compressor without charge in system.

Addition of R-410A will raise pressures (vapor, liquid and discharge).

If adding R-410A raises both vapor pressure and temperature, the unit is over-charged.

IMPORTANT: Use industry-approved charging methods to ensure proper system charge.

CAUTION

R-410A PRESSURES ARE APPROXIMATELY 60% HIGHER THAN R-22 PRESSURES. USE APPROPRIATE CARE WHEN USING THIS REFRIGERANT. FAILURE TO EXERCISE CARE MAY RESULT IN EQUIPMENT DAMAGE, OR PERSONAL INJURY.

15.2 Charging By Liquid Pressure

Liquid pressure method is used for charging systems in the cooling and heating mode. The service port on the liquid service valve (small valve) and suction (large valve) is used for this purpose.

Verify that the outdoor unit is running and the indoor air mover is delivering the maximum airflow for this system size. Read and record the outdoor ambient temperature. Read and record the liquid and suction pressures at the ports on the liquid and suction valves. If refrigerant lines are sized using the nameplate charge, the correct liquid pressure is found at the intersection of the suction pressure and the outdoor ambient.

1. Remove refrigerant charge if the liquid pressure is above the chart value.
2. Add refrigerant charge if the liquid pressure is below the chart value.

15.3 Charging By Weight

For a new installation, evacuation of interconnecting tubing and indoor coil is adequate; otherwise, evacuate the entire system. Use the factory charge shown in Table 1 of these instructions or unit data plate. Note that charge value includes charge required for 15 ft. of standard size interconnecting liquid line. Calculate actual charge required with installed liquid line size and length using:

1/4" O.D. = .3 oz./ft.

5/16" O.D. = .4 oz./ft.

3/8" O.D. = .6 oz./ft.

1/2" O.D. = 1.2 oz./ft.

With an accurate scale (+/- 1 oz.) or volumetric charging device, adjust charge difference between that shown on the unit data plate and that calculated for the new system installation. If the entire system has been evacuated, add the total calculated charge.

15.4 Final Leak Testing

After the unit has been properly evacuated and charged, a halogen leak detector should be used to detect leaks in the system. All piping within the condensing unit, evaporator, and interconnecting tubing should be checked for leaks. If a leak is detected, the refrigerant should be recovered before repairing the leak. The Clean Air Act prohibits releasing refrigerant into the atmosphere.

WARNING

TURN OFF ELECTRIC POWER AT THE FUSE BOX OR SERVICE PANEL BEFORE MAKING ANY ELECTRICAL CONNECTIONS.

ALSO, THE GROUND CONNECTION MUST BE COMPLETED BEFORE MAKING LINE VOLTAGE CONNECTIONS. FAILURE TO DO SO CAN RESULT IN ELECTRICAL SHOCK, SEVERE PERSONAL INJURY OR DEATH.

16.0 ACCESSORIES

16.1 Remote Outdoor Temperature Kit (Part No. 47-102709-03)

This is a kit that has a longer remote sensor that can be installed away from the outdoor unit for better thermostat temperature display.

17.0 TROUBLESHOOTING

IMPORTANT: The JEC series units with the ICC (Integrated Compressor Control) provide status and diagnostic information that greatly enhances the ability to quickly diagnose system faults. Use the following troubleshooting guides as another tool in system diagnostics.

NOTE: In diagnosing common faults in the cooling system, develop a logical thought pattern as used by experienced technicians. The charts which follow are not intended to be an answer to all problems but only to guide the technician's troubleshooting. Through a series of yes and no answers, follow the logical path to a likely conclusion.

A novice technician should use these charts like a road map. Remember that the chart should clarify a logical path to the solution.

17.1 *Comfort Control² SystemTM* Initial Startup

Connect the system.

There are four wires that need to be connected to each unit.

R 24 VAC

C 24 VAC common

1 Communications

2 Communications

Thermostat	Air Handler Furnace Indoor	Air Conditioner Heat Pump Outdoor
R ----- R	R ----- R	R ----- R
1 ----- 1	1 ----- 1	1 ----- 1
2 ----- 2	2 ----- 2	2 ----- 2
C ----- C	C ----- C	C ----- C

These wires need to be connected to each device thermostat, indoor air handler and outdoor unit (heat pump or AC).

If the communications wires are wired backwards at any point the green LED (DS2) will always be on. If this happens check the wires at each point to ensure they are not reversed.

Once all devices are connected power up the line and low voltage to the system. When all devices are powered the thermostat should detect the indoor and outdoor units within 60 seconds. The air handler and outdoor units have a set of bias dip-switches set at a factory default to the ON position. These dipswitches are for future use DO NOT CHANGE DIP SWITCHES.

Once the system is powered the airflow settings will be configured for all devices. The outdoor unit will send information to configure indoor airflow. If the indoor unit is incapable of supplying the required airflow a d3 fault will be displayed on the thermostat and outdoor unit.

All devices have a LEARN button. This button is for future use and currently has no function at this time.

IMPORTANT: DO NOT USE A PHONE CORD TO CONNECT INDOOR AND OUTDOOR UNITS. THIS WILL DAMAGE THE CONTROLS.

IMPORTANT: DO NOT CONNECT THE SYSTEM TO A PHONE LINE. THIS WILL DAMAGE THE CONTROLS.

ADVANCED SETTINGS

All adjustments for airflow are made at the thermostat at this point. Items that can be changed are Airflow trim adjustment Dehumidification Setpoint and mode of operation. The thermostat also has a wide range of fault and history information. The following tables show all of the available options by unit type. To go down into a menu press Install Config to move back up press the Menu button. See Installation Instructions.

17.2 REPLACEMENT OF *COMFORT CONTROL² SYSTEMTM* CONTROL BOARD

Each control board in the *Comfort Control² SystemTM* needs information specific to the unit the control is installed in. This information is called shared data because it is distributed (shared) on the HVAC network. The shared data for a unit contains information that allows the unit to operate correctly.

FIGURE 10
COMFORT CONTROL² SYSTEMTM CONTROL BOARD REPLACEMENT

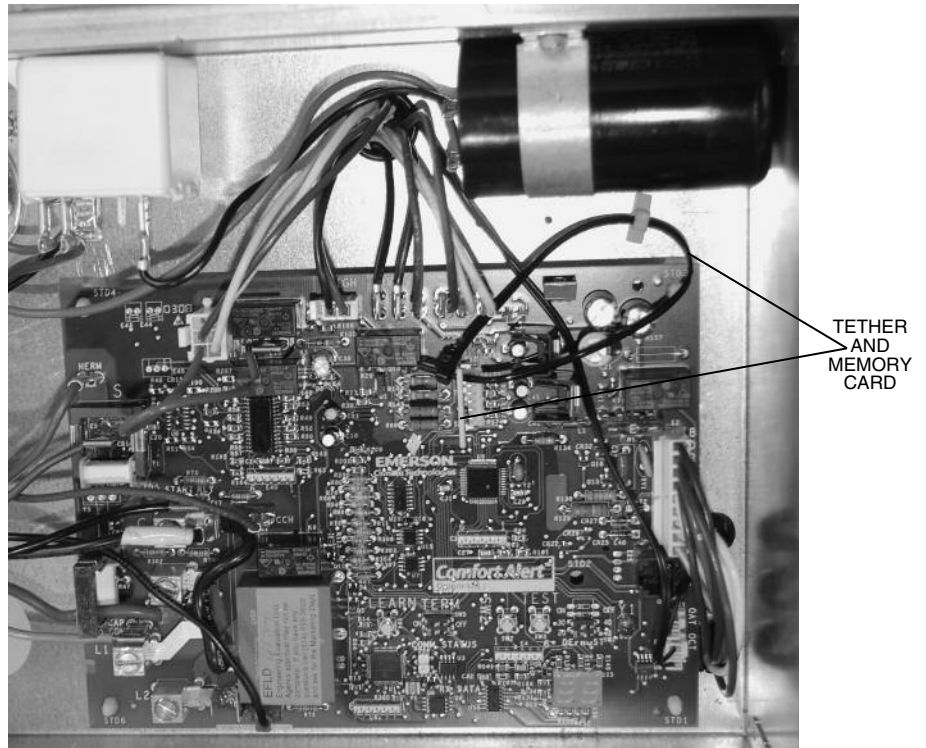

When a control board requires replacement, it is important that the replacement board gets the shared data from the old control. The primary way the replacement control gets this information is by the memory card that should be installed on the old control. Remove the memory card from the old control, but leave it attached to the unit by the plastic tether, replace the control and reinstall the memory card on the new control. If for some reason the memory card has been damaged or is missing, the shared data from the network (air handler) will be used by the control. The network shared data is considered a back up for a lost or missing memory card. Never remove the memory card from the unit or cut the tether of the memory card as it is the most effective way to transfer the shared data. If the memory card is damaged or missing a new memory card can be ordered from Pro Stock. The unit will operate without the memory card, but a D4 error will be displayed on the seven segment displays.

The memory card from a different unit should never be used.

17.3 Electrical Checks Flow Chart

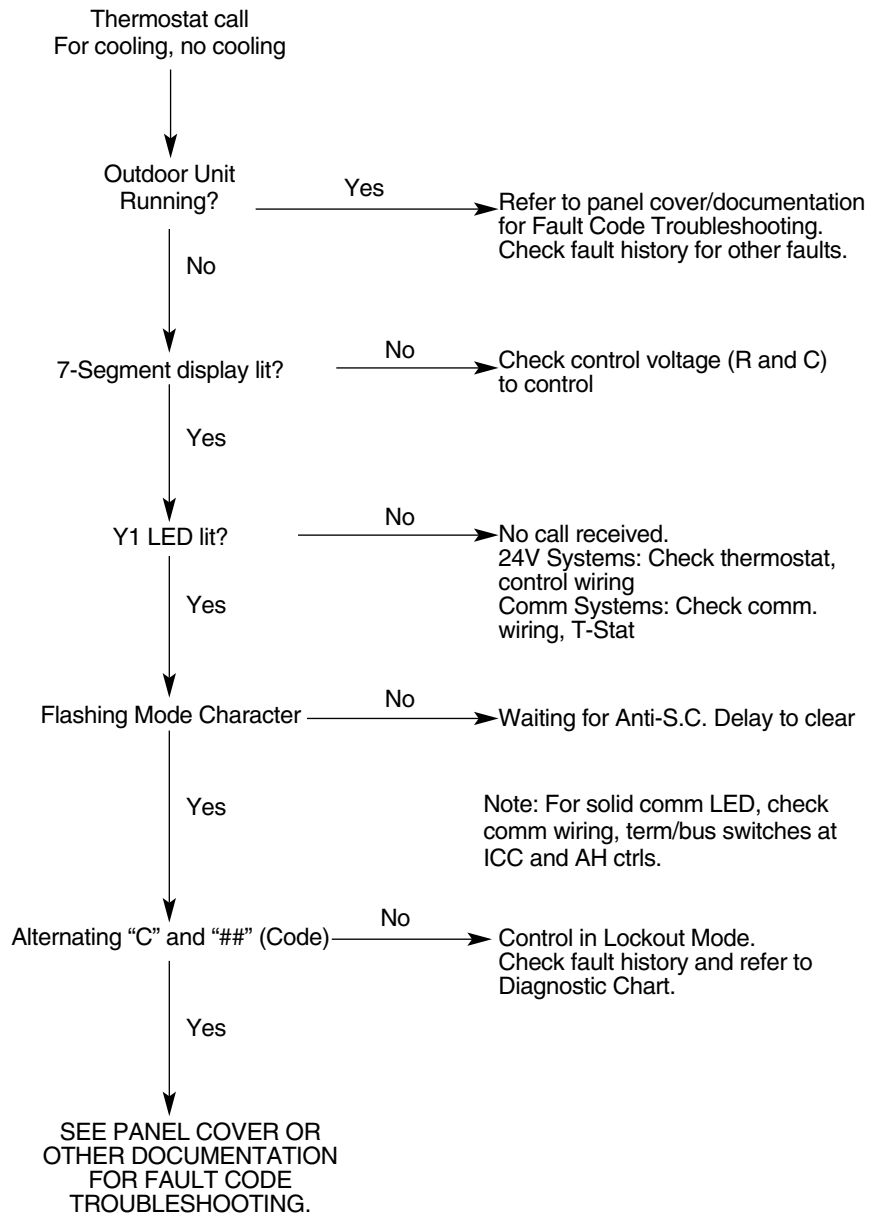

17.4 Cooling Mechanical Checks Flow Chart

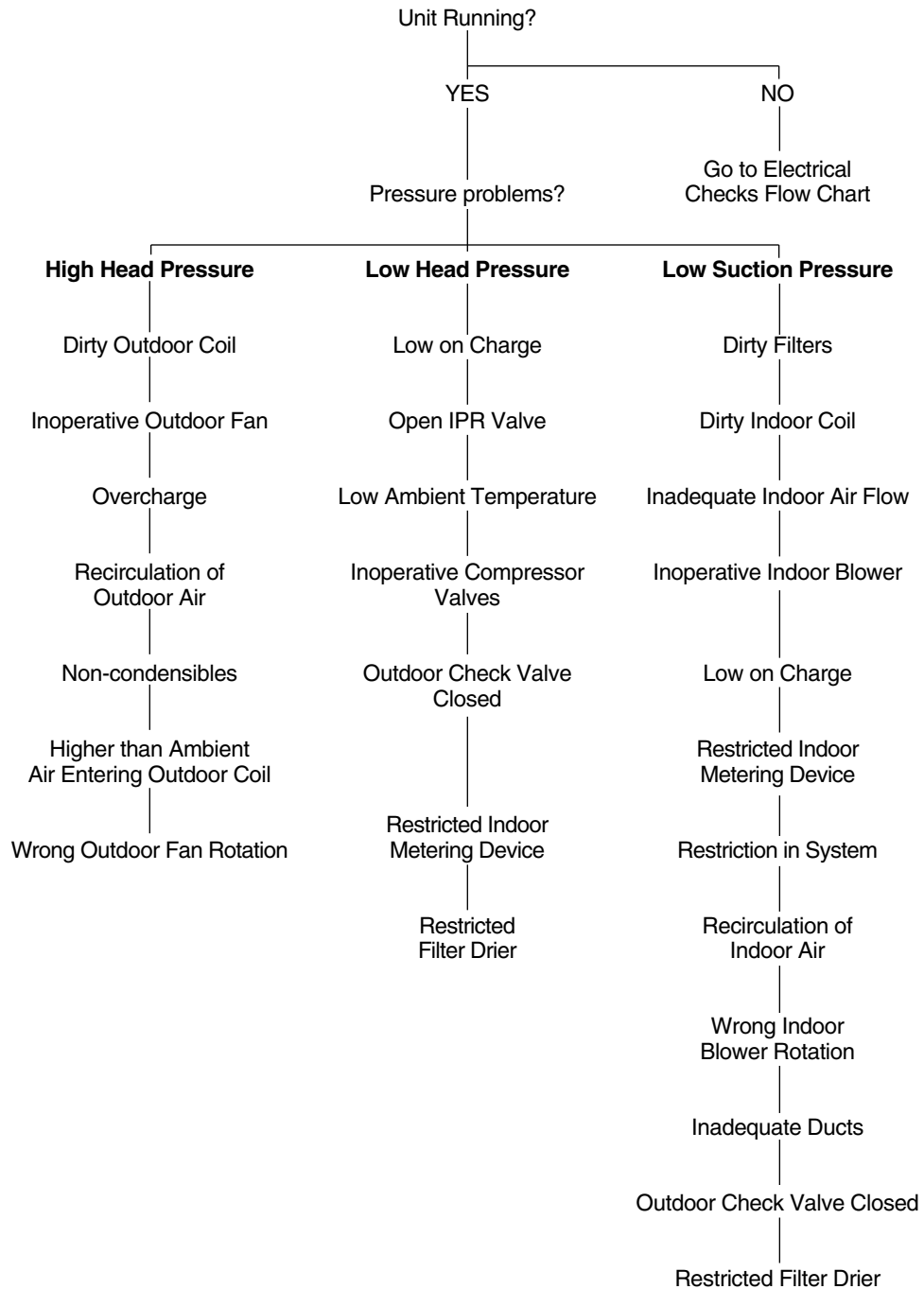

17.5 General Trouble Shooting Chart

▲ WARNING

DISCONNECT ALL POWER TO UNIT BEFORE SERVICING. CONTACTOR MAY BREAK ONLY ONE SIDE. FAILURE TO SHUT OFF POWER CAN CAUSE ELECTRICAL SHOCK RESULTING IN PERSONAL INJURY OR DEATH.

SYMPTOM	POSSIBLE CAUSE	REMEDY
Unit will not run	<ul style="list-style-type: none"> Power off or loose electrical connection Thermostat out of calibration-set too high Defective contactor Blown fuses / tripped breaker Transformer defective High pressure control open (if provided) 	<ul style="list-style-type: none"> Check for correct voltage at contactor in condensing unit Reset Check for 24 volts at contactor coil - replace if contacts are open Replace fuses / reset breaker Check wiring-replace transformer Reset-also see high head pressure remedy-The high pressure control opens at 450 PSIG
Outdoor fan runs, compressor doesn't	<ul style="list-style-type: none"> Run or start capacitor defective Start relay defective Loose connection Compressor stuck, grounded or open motor winding, open internal overload. Low voltage condition 	<ul style="list-style-type: none"> Replace Replace Check for correct voltage at compressor - check & tighten all connections Wait at least 2 hours for overload to reset. If still open, replace the compressor. Add start kit components
Insufficient cooling	<ul style="list-style-type: none"> Improperly sized unit Improper indoor airflow Incorrect refrigerant charge Air, non-condensibles or moisture in system 	<ul style="list-style-type: none"> Recalculate load Check - should be approximately 400 CFM per ton. Charge per procedure attached to unit service panel Recover refrigerant, evacuate & recharge, add filter drier
Compressor short cycles	<ul style="list-style-type: none"> Incorrect voltage Defective overload protector Refrigerant undercharge 	<ul style="list-style-type: none"> At compressor terminals, voltage must be $\pm 10\%$ of nameplate marking when unit is operating. Replace - check for correct voltage Add refrigerant
Registers sweat	<ul style="list-style-type: none"> Low indoor airflow 	<ul style="list-style-type: none"> Increase speed of blower or reduce restriction - replace air filter
High head-low vapor pressures	<ul style="list-style-type: none"> Restriction in liquid line, expansion device or filter drier Flowcheck piston size too small Incorrect capillary tubes 	<ul style="list-style-type: none"> Remove or replace defective component Change to correct size piston Change coil assembly
High head-high or normal vapor pressure - Cooling mode	<ul style="list-style-type: none"> Dirty outdoor coil Refrigerant overcharge Outdoor fan not running Air or non-condensibles in system 	<ul style="list-style-type: none"> Clean coil Correct system charge Repair or replace Recover refrigerant, evacuate & recharge
Low head-high vapor pressures	<ul style="list-style-type: none"> Flowcheck piston size too large Defective Compressor valves Incorrect capillary tubes 	<ul style="list-style-type: none"> Change to correct size piston Replace compressor Replace coil assembly
Low vapor - cool compressor - iced indoor coil	<ul style="list-style-type: none"> Low indoor airflow Operating below 65°F outdoors Moisture in system 	<ul style="list-style-type: none"> Increase speed of blower or reduce restriction - replace air filter Add Low Ambient Kit Recover refrigerant - evacuate & recharge - add filter drier
High vapor pressure	<ul style="list-style-type: none"> Excessive load Defective compressor 	<ul style="list-style-type: none"> Recheck load calculation Replace
Fluctuating head & vapor pressures	<ul style="list-style-type: none"> TXV hunting Air or non-condensibles in system 	<ul style="list-style-type: none"> Check TXV bulb clamp - check air distribution on coil - replace TXV Recover refrigerant, evacuate & recharge
Gurgle or pulsing noise at expansion device or liquid line	<ul style="list-style-type: none"> Air or non-condensibles in system 	<ul style="list-style-type: none"> Recover refrigerant, evacuate & recharge
Unit will not run	<ul style="list-style-type: none"> Miswiring of communications (communication light on continuously) 	<ul style="list-style-type: none"> Check communication wiring

17.6 Service Analyzer Charts

COMPRESSOR OVERHEATING		
SYMPTOMS	POSSIBLE CAUSE	CHECK/REMEDIES
High superheat	Low charge	Check system charge
	Faulty metering device	Restricted cap tube, TEV (TXV)
		Power element superheat adjustment
		Foreign matter stopping flow
	High internal load	Hot air (attic) entering return
		Heat source on; mis-wired or faulty control
	Restriction in liquid line	Drier plugged
		Line kinked
	Low head pressure	Low charge
		Operating in low ambient temperatures
Suction or liquid line subjected to high heat source	Hot attic	
	Hot water line	
Low voltage	Loose wire connections	Check wiring
	Power company problem, transformer	Have problem corrected before diagnosis continues
	Undersized wire feeding unit	Correct and complete diagnosis
High voltage	Power company problem	Have problem corrected
High head pressure	Overcharge	Check system charge
	Dirty heat pump coil	Clean coil
	Faulty or wrong size heat pump fan motor	Replace fan motor
	Faulty fan blade or wrong rotation	Replace fan blade
		Replace with correct rotation motor
	Recirculation of air	Correct installation
	Additional Heat Source	Check for dryer vent near unit
		Check for recirculation from other equipment
	Non-condensibles	Recover refrigerant, Evacuate and recharge system
Equipment not matched	Correct mis-match	
Short cycling of compressor	Faulty pressure control	Replace pressure control
	Loose wiring	Check unit wiring
	Thermostat	Located in supply air stream
		Differential setting too close
		Customer misuse
	TEV	Internal foreign matter
		Power element failure
		Valve too small
		Distributor tube/tubes restricted
	Capillary tube	Restricted with foreign matter
		Kinked
I.D. reduced from previous compressor failure		

SYMPTOMS	POSSIBLE CAUSE	CHECK OR REMEDIES	
Short cycling of compressor (cont.)	Low charge	Check system charge	
	Low evaporator air flow	Dirty coil	
		Dirty filter	
		Duct too small or restricted	
	Faulty run capacitor	Replace	
Faulty internal overload	Replace compressor		
Faulty Compressor Valves	Fast equalization/ Low pressure difference	Replace compressor and examine system to locate reason	
<i>ELECTRICAL</i>			
SYMPTOMS	POSSIBLE CAUSE	CHECK OR REMEDIES	
Voltage present on load side of compressor contactor and compressor won't run	Compressor start components	Check start capacitor	
		Check potential relay	
	Run capacitor	Check with ohmmeter	
	Internal overload	Allow time to reset	
Voltage present on line side of pressor contactor only	Compressor windings	Check for correct ohms	
	Thermostat	Check for control voltage to com- contactor coil	
		Compressor control circuit	High pressure switch
			Low pressure switch
			Ambient thermostat
Solid state protection control or internal thermal sensors			
Compressor timed off/on control or interlock			
No voltage on line side of compressor contactor	Blown fuses or tripped circuit breaker	Check for short in wiring or unit	
	Improper wiring	Re-check wiring diagram	
Improper voltage	High voltage	Wrong unit	
		Power supply problem	
	Low voltage	Wrong unit	
		Power supply problem	
		Wiring undersized	
	Loose connections		
Single Phasing (3 phase)	Check incoming power and fusing		
<i>CONTAMINATION</i>			
SYMPTOMS	POSSIBLE CAUSE	CHECK OR REMEDIES	
Moisture	Poor evacuation on installation or during service	In each case, the cure is the same. Recover refrigerant. Add filter drier, evacuate and re-charge	
High head pressure	Non-condensibles air		
Unusual head and suction readings	Wrong refrigerant		
Foreign Matter- copper filings	Copper tubing cuttings		
Copper oxide	Dirty copper piping		
Welding scale	Nitrogen not used		
Soldering flux	Adding flux before seating copper part way		
Excess soft solder	Wrong solder material		

LOSS OF LUBRICATION		
SYMPTOMS	POSSIBLE CAUSE	CHECK OR REMEDIES
Compressor failures	Line tubing too long	Add oil to the recommended level
	Line tubing too large	Reduce pipe size to improve oil return
Low suction pressure	Low charge	Check system charge
	Refrigerant leaks	Repair and recharge
Cold, Noisy compressor - Slugging	Dilution of Oil with Refrigerant	Observe piping guidelines
Noisy compressor	Migration	Check crankcase heater
Cold, sweating compressor	Flooding	Check system charge
Low Load	Reduced air flow	Dirty filter
		Dirty coil
		Wrong duct size
		Restricted duct
Short cycling of compressor	Thermostat setting	Advise customer
	Faulty pressure control	Replace control
	Loose wiring	Check all control wires
	Thermostat	In supply air stream, out of calibration, Customer misuse
FLOODED STARTS		
SYMPTOMS	POSSIBLE CAUSES	CHECK OR REMEDIES
Liquid in the compressor shell	Faulty or missing crankcase heater	Replace crankcase heater
Too much liquid in system	Incorrect piping	Check Piping guidelines
	Overcharge	Check and adjust charge
SLUGGING		
SYMPTOMS	POSSIBLE CAUSES	CHECK OR REMEDIES
On start up	Incorrect piping	Review pipe size guidelines
TEV hunting when running	Oversized TEV	Check TEV application
FLOODING		
SYMPTOMS	POSSIBLE CAUSES	CHECK OR REMEDIES
Poor system control using a TEV	Loose sensing bulb	Secure the bulb and insulate
	Bulb in wrong location	Relocate bulb
	Wrong size TEV	Use correct replacement
	Improper superheat setting	Adjust, if possible; Replace, if not
Poor system control using capillary tubes	Overcharge	Check system charge
	High head pressures	Dirty heat pump
		Restricted air flow
	Evaporator air flow too low	Recirculation of air Adjust air flow to 400 CFM/Ton

THERMOSTATIC EXPANSION VALVES

SYMPTOMS	POSSIBLE CAUSE	CHECK OR REMEDIES	
High Superheat, Low Suction Pressure	Moisture freezing and blocking valve	Recover charge, install filter-drier, evacuate system, recharge	
	Dirt or foreign material blocking valve	Recover charge, install filter-drier, evacuate system, recharge	
	Low refrigerant charge	Correct the charge	
	Vapor bubbles in liquid line	Remove restriction in liquid line	Remove restriction in liquid line
		Correct the refrigerant charge	Correct the refrigerant charge
		Remove non-condensable gases	Remove non-condensable gases
	Misapplication of internally equalized valve	Use correct TEV	Use correct TEV
		Plugged external equalizer line	Remove external equalizer line restriction
	Undersized TEV	Replace with correct valve	
	Loss of charge from power head sensing bulb	Replace power head or complete TEV	
	Charge migration from sensing bulb to power head (Warm power head with warm, wet cloth. Does valve operate correctly now?)	Ensure TEV is warmer than sensing bulb	
Improper superheat adjustment (Only applicable to TEV with adjustable superheat settings)	Adjust superheat setting counter-clockwise		
Valve feeds too much refrigerant, with low superheat and higher than normal suction pressure	Moisture causing valve to stick open.	Recover refrigerant, replace filter-drier, evacuate system and then non-recharge	
	Dirt or foreign material causing valve to stick open	Recover refrigerant, replace filter-drier, evacuate system and recharge	
	TEV seat leak (A gurgling or hissing sound is heard AT THE TEV during the off cycle, if this is the cause.) NOT APPLICABLE TO BLEED PORT VALVES.	Replace the TEV	
	Oversized TEV	Install correct TEV	
	Incorrect sensing bulb location	Install bulb with two mounting straps, in 2:00 or 4:00 position on suction line, with insulation	
	Low superheat adjustment (only applicable to TEV with adjustable superheat setting)	Turn superheat adjustment clockwise	
	Incorrectly installed, or restricted external equalizer line	Remove restriction, or relocate external equalizer	
Compressor flood back upon start up	Refrigerant drainage from flooded evaporator	Install trap riser to the top of the evaporator coil	
	Compressor in cold location	Install crankcase heater on compressor	
	Any of the causes listed under Symptoms of Problem #2	Any of the solutions listed under Solutions of Problem #2	

THERMOSTATIC EXPANSION VALVES

SYMPTOMS	POSSIBLE CAUSE	CHECK OR REMEDIES
Superheat is low to normal with low suction pressure	Unequal evaporator circuit loading	Ensure air flow is equally distributed through evaporator Check for blocked distributor tubes
	Low load or airflow entering evaporator coil	Ensure blower is moving proper air CFM Remove/Correct any air flow restriction
Superheat and suction pressure fluctuate (valve is hunting)	Expansion valve is oversized	Install correct TEV
	Sensing bulb is affected by liquid refrigerant or refrigerant oil flowing through suction line	Relocate sensing bulb in another position around the circumference of the suction line
	Unequal refrigerant flow through evaporator circuits	Ensure sensing bulb is located properly
		Check for blocked distributor tubes
	Improper superheat adjustment (only possible with TEV having superheat adjustment)	Replace TEV or adjust superheat
	Moisture freezing and partially blocking TEV	Recover refrigerant, change filter-drier, evacuate system and recharge
Valve does not regulate at all	External equalizer line not connected or line plugged	Connect equalizer line in proper location, or remove any blockage
	Sensing bulb lost its operating charge	Replace TEV
	Valve body damaged during soldering or by improper installation	Replace TEV

TABLE 8
TEMPERATURE PRESSURE CHART

TEMP (Deg. F)	R-410A PSIG
-150	—
-140	—
-130	—
-120	—
-110	—
-100	—
-90	—
-80	—
-70	—
-60	0.4
-50	5.1
-40	10.9
-35	14.2
-30	17.9
-25	22.0
-20	26.4
-15	31.3
-10	36.5
-5	42.2
0	48.4
5	55.1
10	62.4
15	70.2
20	78.5
25	87.5
30	97.2
35	107.5
40	118.5
45	130.2
50	142.7
55	156.0
60	170.1
65	185.1
70	201.0
75	217.8
80	235.6
85	254.5
90	274.3
95	295.3
100	317.4
105	340.6
110	365.1
115	390.9
120	418.0
125	446.5
130	476.5
135	508.0
140	541.2
145	576.0
150	612.8

17.7 Subcooling Calculation

1. Measure the liquid pressure at the liquid line service valve.
2. Convert the liquid line pressure to saturated temperature. See Table 8.
3. Measure the liquid line temperature at the liquid line service valve.
4. Compare the liquid line temperature to the saturated temperature.
5. The difference between saturated temperature and liquid line temperature is the subcooling. Subcooling normal range 9° to 12°.

TABLE 9
AIR CONDITIONING SYSTEM TROUBLESHOOTING TIPS

AIR CONDITIONING SYSTEM TROUBLESHOOTING TIPS					
SYSTEM PROBLEM	INDICATORS				
	DISCHARGE PRESSURE	SUCTION PRESSURE	SUPERHEAT	SUBCOOLING	COMPRESSOR AMPS
Overcharge	High	High	Low	High	High
Undercharge	Low	Low	High	Low	Low
Liquid Restriction (Drier)	Low	Low	High	High	Low
Low Evaporator Airflow	Low	Low	Low	Low	Low
Dirty Heat Pump	High	High	Low	Low	High
Low Outside Ambient Temperature	Low	Low	High	High	Low
Inefficient Compressor	Low	High	High	High	Low
TXV Feeler Bulb Charge Lost	Low	Low	High	High	Low
Poorly Insulated Sensing Bulb	High	High	Low	Low	High

18.0 WIRING DIAGRAMS

FIGURE 11
WIRING DIAGRAM FOR 2, 3, & 4 TON

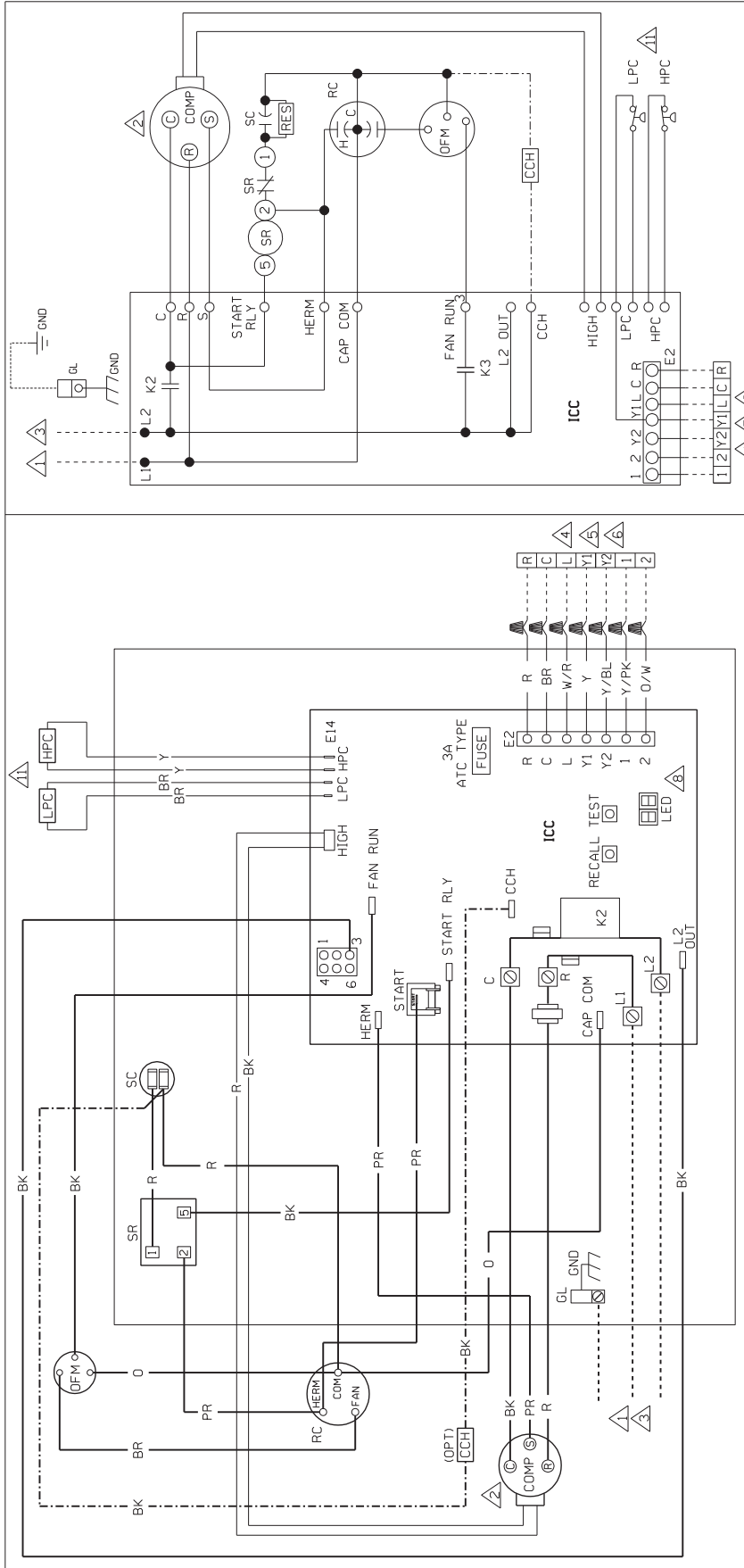

WIRING SCHEMATIC		WIRING INFORMATION	
<p>WIRE COLOR CODE</p> <p>BK BLACK BR BROWN BL BLUE G GREEN R RED O ORANGE PK PINK PR PURPLE W WHITE Y YELLOW</p>		<p>LINE VOLTAGE</p> <p>-FACTORY STANDARD -FACTORY OPTION -FIELD INSTALLED LOW VOLTAGE -FACTORY STANDARD -FIELD INSTALLED REPLACEMENT WIRE MUST BE THE SAME SIZE AND TYPE OF INSULATION AS ORIGINAL (105 C° MIN.) WARNING -CABINET MUST BE PERMANENTLY GROUNDED AND CONFORM TO I.E.C., N.E.C., C.E.C. AND LOCAL CODES AS APPLICABLE.</p>	
<p>ELECTRICAL WIRING DIAGRAM</p> <p>AIR CONDITIONER 2 STAGE INTEGRATED COMPRESSOR CONTROL</p>		<p>NOTES:</p> <ol style="list-style-type: none"> CONNECTORS SUITABLE FOR USE WITH COPPER CONDUCTORS ONLY. COMPRESSOR MOTOR THERMALLY PROTECTED. CONNECT FIELD WIRING IN GROUNDED PAINTIGHT CONDUIT TO FUSED DISCONNECT, VOLTAGE, HERTZ AND PHASE PER RATING PLATE, AND PER NATIONAL AND LOCAL CODES. LOW VOLTAGE CIRCUIT TO BE N.E.C. CLASS 2 WITH A CLASS 2 TRANSFORMER 24 VOLTS, 50 OR 60 HERTZ, MIN. 18 AWG. TO THERMOSTAT, REFER TO SYSTEM SCHEMATICS OR SCHEMATICS ON INDOOR SECTION FOR LOW VOLTAGE CONTROL WIRING. L OUTPUT USED ON CERTAIN MODEL THERMOSTATS WITH L TERMINAL. TEST AND SW2 PUSH-BUTTONS USED FOR TEST AND DIAGNOSTIC RECALL. SEE PUSH-BUTTON LABEL FOR DETAILS. 7-SEGMENT LED TO DISPLAY DIAGNOSTIC CODES. SEE DIAGNOSTIC LABEL FOR DETAILS. TORQUE REQUIREMENTS 20 IN.-LB. CHECK ANNUALLY. SOLID ON INDICATES Y1 CALL PRESENT AT ICC CONTROL. LPC AND HPC ARE AUTOMATIC RESET SWITCHES. 	
<p>COMPONENT CODE</p> <p>CCH CRANK CASE HEATER COMP COMPRESSOR BOARD WIRE TERMINATION E CONTROL BOARD WIRE TERMINATION GL GROUND LUG GND GROUND, CHASSIS ICC INTEGRATED COMPRESSOR CONTROL K HIGH PRES. CUT-OUT CONTROL LPC LOW PRESSURE CONTROL OPF OPTIONAL FAN MOTOR OPY OPTIONAL FAN MOTOR RC RESISTOR RSC RUN CAPACITOR SR START CAPACITOR SC START RELAY</p>		<p>WIRING INFORMATION</p> <p>LINE VOLTAGE -FACTORY STANDARD -FACTORY OPTION -FIELD INSTALLED LOW VOLTAGE -FACTORY STANDARD -FIELD INSTALLED REPLACEMENT WIRE MUST BE THE SAME SIZE AND TYPE OF INSULATION AS ORIGINAL (105 C° MIN.) WARNING -CABINET MUST BE PERMANENTLY GROUNDED AND CONFORM TO I.E.C., N.E.C., C.E.C. AND LOCAL CODES AS APPLICABLE.</p>	
<p>DWG. NO. 90-102075-04</p>		<p>REV 02</p>	

FIGURE 12
WIRING DIAGRAM FOR 5 TON

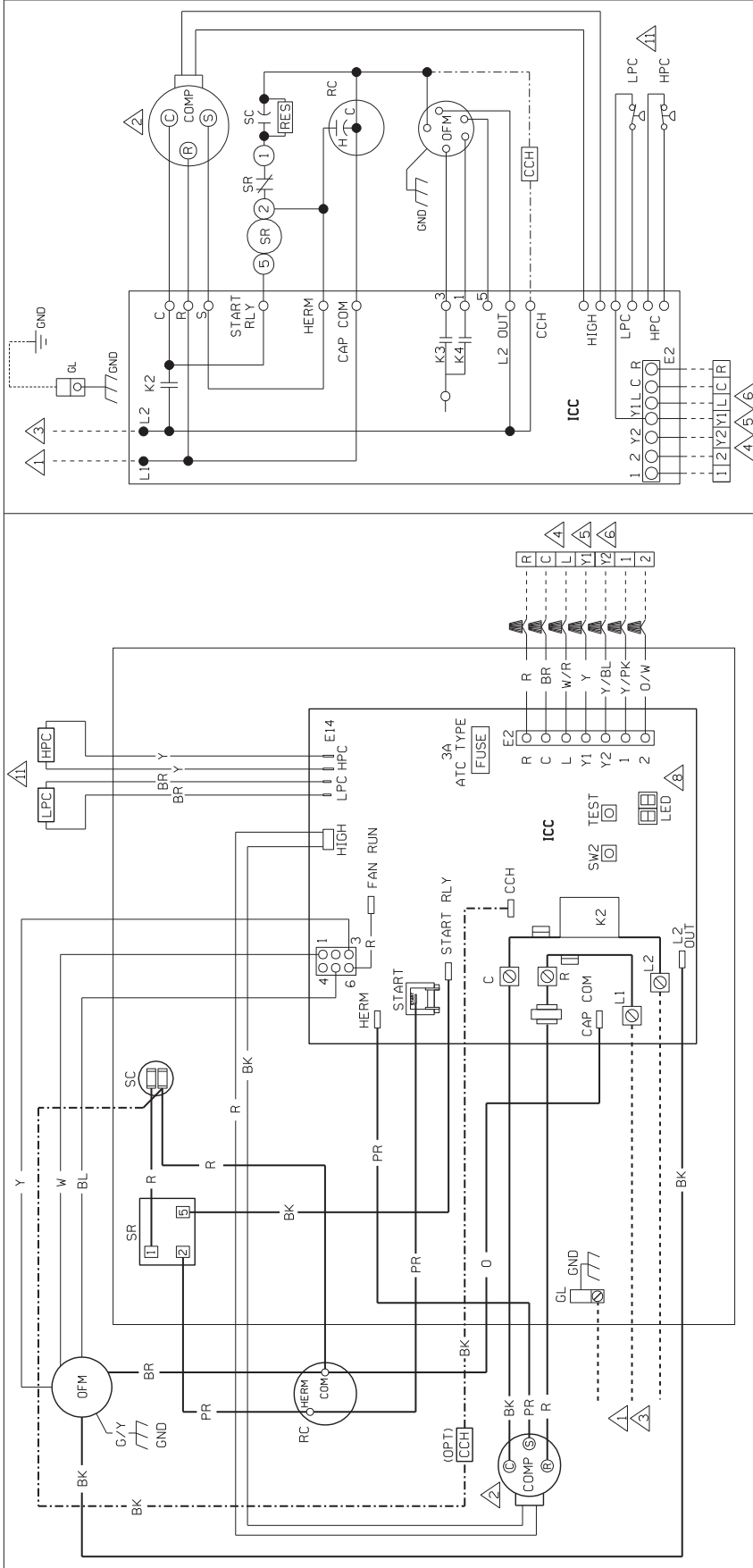

WIRING SCHEMATIC

WIRE COLOR CODE	
BK	BLACK
BR	BROWN
BL	BLUE
G	GREEN
GY	GRAY
O	ORANGE
PK	PINK
PR	PURPLE
R	RED
W	WHITE
Y	YELLOW

WIRING INFORMATION	
LINE VOLTAGE	—
-FACTORY STANDARD	---
-FACTORY OPTION	----
-FIELD INSTALLED	-----
LOW VOLTAGE	-----
-FACTORY STANDARD	-----
-FACTORY OPTION	-----
-FIELD INSTALLED	-----
REPLACEMENT WIRE	-----
-MUST BE THE SAME SIZE AND TYPE OF INSULATION AS ORIGINAL (105 C MIN.)	
-CABINET MUST BE PERMANENTLY GROUNDED AND CONFORM TO I.E.C., N.E.C., C.E.C. AND LOCAL CODES AS APPLICABLE.	

WIRING DIAGRAM

- NOTES:**
- CONNECTORS SUITABLE FOR USE WITH COPPER CONDUCTORS ONLY.
 - COMPRESSOR MOTOR THERMALLY PROTECTED.
 - CONNECT FIELD WIRING IN GROUNDED RAINTIGHT CONDUIT TO FUSED DISCONNECT, VOLTAGE, HERTZ AND PHASE PER RATING PLATE, AND PER NATIONAL AND LOCAL CODES.
 - LOW VOLTAGE CIRCUIT TO BE N.E.C. CLASS 2 WITH A CLASS 2 TRANSFORMER 24 VOLT, 50 OR 60 HERTZ, MIN 18 AWG.
 - TO THERMOSTAT, REFER TO SYSTEM SCHEMATICS OR SCHEMATICS ON INDOOR SECTION FOR LOW VOLTAGE CONTROL WIRING.
 - L OUTPUT USED ON CERTAIN MODEL THERMOSTATS WITH L TERMINAL.
 - TEST AND SW2 PUSH BUTTONS USED FOR TEST AND DIAGNOSTIC RECALL-SEE PUSH BUTTON LABEL FOR DETAILS.
 - 7-SEGMENT LED TO DISPLAY DIAGNOSTIC CODES. SEE DIAGNOSTIC LABEL FOR DETAILS.
 - TORQUE REQUIREMENTS 20 IN.-LB. CHECK ANNUALLY.
 - SOLID ON INDICATES Y1 CALL PRESENT AT ICC CONTROL.
 - LPC AND HPC ARE AUTOMATIC RESET SWITCHES.

COMPONENT CODE	
CCH	CRANK CASE HEATER
COMP	COMPRESSOR
E1	WIRE TERMINATION
GND	GROUND
LPC	OUTDOOR FAN MOTOR
OFM	OUTDOOR FAN MOTOR
RES	RESISTOR
SC	START RELAY
SR	START RELAY
W	WIRE
Y	YELLOW
Z	WIRE TERMINATION

DWG. NO.	90-102075-05	REV	02
----------	--------------	-----	----

DR. BY	APP. BY	DATE	DWG. NO.
	MCB	9-17-07	90-102075-05

ELECTRICAL WIRING DIAGRAM	
AIR CONDITIONER	
2 STAGE	
INTEGRATED COMPRESSOR CONTROL	

REV	02
-----	----

DWG. NO.	90-102075-05
----------	--------------