

# CONDENSING UNITS



## RANL- \*AZ R410A

13 SEER Models  
Nominal Sizes 1 1/2 to 5 Tons  
[5.28 kW] to [17.6 kW]

### Seven Models

Cooling Capacities  
18,300 to 62,000 BTU/HR  
[5.36 kW] to [18.17 kW]



The Rheem *Classic*® Series High Efficiency RANL- Condensing Units were designed with performance in mind. These units offer comfort, energy conservation and dependability for single, multi-family and light commercial applications.

These units also contain the most advanced alternate refrigerant which contains no chlorofluorocarbons (CFCs), or hydrochlorofluorocarbons (HCFCs), or other compounds that may leak from air-conditioning systems and potentially harm the protective ozone layer of the Earth's atmosphere.

The Rheem *Classic*® Series RANL- Condensing Units are the result of an ongoing development program for improved efficiencies. These units are flexible enough to achieve up to 15.00 SEER in specific match-ups, continuing a tradition of high efficiency.

- Attractive, louvered wrap-around jacket protects the coil from yard hazards and weather extremes. Top grille is steel reinforced for extra strength. Cabinet is powder painted for all-weather protection.
- Air is discharged upward away from bushes and shrubs. The discharge pattern of the top grille provides minimum air restriction.
- Combination Grille/Motor Mount secures the motor to the underside of the discharge grille. The grille protects the motor windings and bearings from rain and snow.
- All controls are accessible by removing one service panel. Removable top grille provides access to the condenser fan motor and condenser coil.
- Single speed 8-pole fan motor designed for low speed, quiet, energy-saving operation.
- All models meet or exceed a 1000-hour salt spray test per ASTM B117 Standard Practice for Operating Salt Spray Testing Apparatus.

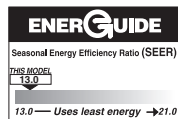

13 SEER MODELS  
(IN CERTAIN MATCHED SYSTEMS)

**"Proper sizing and installation of equipment is critical to achieve optimal performance. Split system air conditioners and heat pumps must be matched with appropriate coil components to meet ENERGY STAR criteria. Ask your Contractor for details or visit [www.energystar.gov](http://www.energystar.gov) <<http://www.energystar.gov/>>."**

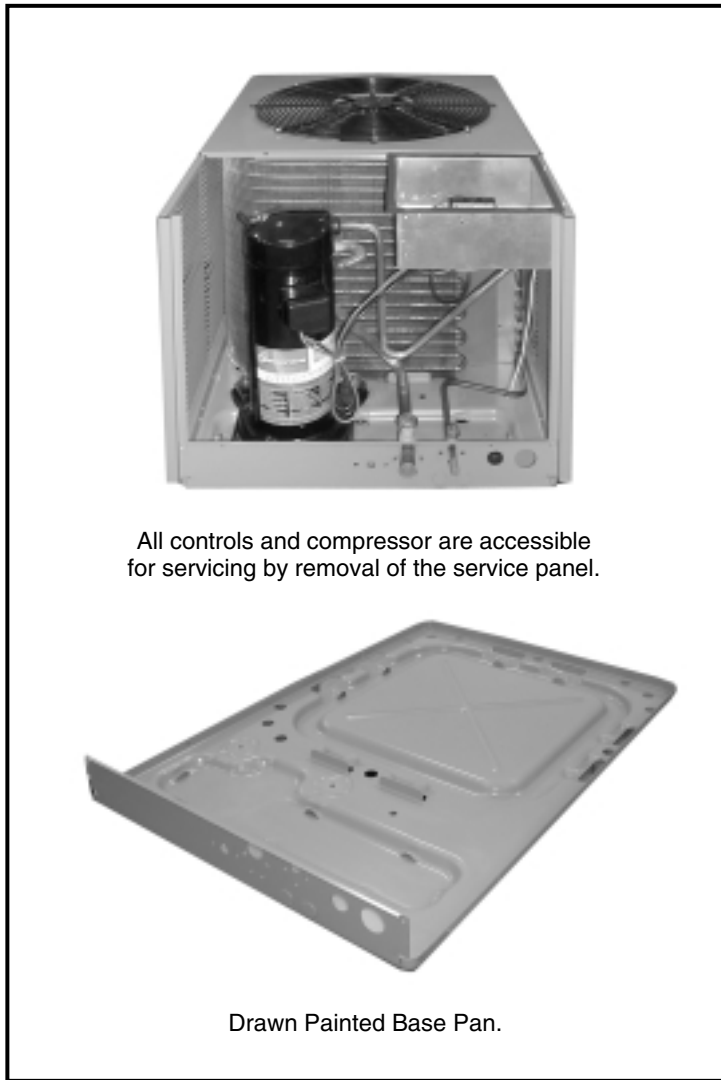

All controls and compressor are accessible for servicing by removal of the service panel.

Drawn Painted Base Pan.

## Engineering Features

### RANL- Series Condensing Units

1. This unit contains a special scroll compressor that is designed specifically to operate with R-410A refrigerants and polyolester (POE) oils. The compressor is hermetically sealed and incorporates internal high temperature motor overload protection and durable insulation on the motor windings. It is externally mounted on rubber grommets to reduce vibration and noise.
2. Compressors have an internal pressure relief assembly to protect against excessive pressure differential.
3. All refrigerant connections are on the exterior of the unit, located close to the ground for neat appearing installations.
4. Cabinet is constructed of powder painted galvanized steel. The full wraparound louvered grille protects the coil from damage.
5. Copper tube—aluminum fin coils are used on all models.
6. The control box is located in the top corner of the cabinet providing for easy access through a service panel.
7. Service valves are standard on all models.
8. Power and control wiring are kept separate.
9. Every unit is factory charged and tested.
10. Separate compressor compartment for easy service access.
11. Drawn, painted base pan for extra corrosion resistance and sound reduction.
12. Automatic reset high and low pressure controls are standard on all models.
13. A liquid line filter drier is standard on all models (shipped – not installed).

## Model Number Identification

<u>R</u>	<u>A</u>	<u>N</u>	<u>L</u>	<u>—</u>	<u>018</u>	<u>J</u>	<u>A</u>	<u>Z</u>
RHEEM	REMOTE CONDENSING UNIT	N = 13 SEER	DESIGN SERIES		COOLING CAPACITY	ELECTRICAL DESIGNATION	VARIATIONS	COOLING CONNECTION FITTING
			L = R-410A		018 = 18,000 BTU/HR [5.28 kW] 024 = 24,000 BTU/HR [7.03 kW] 031 = 30,000 BTU/HR [8.79 kW] 037 = 36,000 BTU/HR [10.55 kW] 043 = 42,000 BTU/HR [12.31 kW] 049 = 48,000 BTU/HR [14.07 kW] 060 = 60,000 BTU/HR [17.58 kW]	J = 208/230V-1-60 C = 208/230V-3-60 (RANL MODELS ONLY) D = 460V-3-60 (RANL MODELS ONLY) Y = 575V-3-60 (RANL 4 & 5 TON MODELS ONLY)	A-SERIES = FULL-FEATURED	Z = SWEAT W/SCROLL

[ ] Designates Metric Conversions

## Field Installed Accessories

- **Compressor Time Delay Control**—Compressor will remain off for five minutes after power or thermostat interruption, allowing system pressures to equalize. (Model No. RXMD-B01)
- **Thermostats**—



**100-Series \***  
Non-Programmable



**200-Series \***  
Programmable



**300-Series \***  
Deluxe Programmable

**400-Series \*** Special Applications/Programmable

**500-Series \***  
Communicating/  
Programmable

- **Low Ambient Control**—Cycles outdoor fan to maintain adequate condensing pressures assuring liquid refrigerant flow to the coil. Allows indoor cooling with outdoor temperatures down to 0°F [-17.8°C]. It is recommended that this control be installed in units to be operated at outdoor ambient temperatures under 65°F (18°C). (Model No. RXAD-A08)
- **Hard Start Components**—(Available through PROSTOCK®)
- **Compressor Crankcase Heater (CCH)**—While scroll compressors usually do not require crankcase heaters, there are instances when a heater should be added. Refrigerant migration during the off cycle can result in a noisy start up. Add a crankcase heater to minimize refrigeration migration, and to help eliminate any start up noise or bearing “wash out”. (Available through PROSTOCK®)

Brand	Unique Model Number Prefix	Descriptor (3 Characters)	Series (3 Characters)	System (2 Characters)	Type (2 Characters)
RHC	-	TST	101	GE	MS
RHC=Rheem		TST=Thermostat	100=Non-Programmable 200=Programmable 300=Deluxe Programmable 400=Special Applications/ Programmable 500=Communicating/ Programmable	GE=Gas/Oil/Electric HP=Heat Pump MD=Modulating Furnace DF=Dual Fuel UN=Universal AC/HP/GE CM=Communicating	SS=Single-Stage MS=Multi-Stage

\* Photos are representative. Actual models may vary.

For detailed thermostat match-up information, see specification sheet form number T11-001.

## SCROLL® COMPRESSOR

The scroll compressor is the key to efficiency for this Rheem model. It's the latest in high-efficiency compressor technology. The advanced scroll compressor offers low noise and vibration characteristics and features tolerance to liquid refrigerant and system contamination. The scroll compressor also has low start torque, reducing start problems in the field. And its unique design enables the RANL- condensing units to perform efficiently, quietly and dependably. RANL- \*AZ has a 10-year compressor warranty.



# Performance Data @ ARI Standard Conditions—Cooling: RANL-

Outdoor Unit RANL-	Model Numbers	80°F [26.5°C] DB/67°F [19.5°C] WB Indoor Air 95°F [35°C] DB Outdoor Air					Sound Rating dB	Indoor CFM [L/s]
	Indoor Coil and/or Air Handler	Total Capacity BTU/H [kW]	Net Sensible BTU/H [kW]	Net Latent BTU/H [kW]	EER	SEER		
Revised 9/12/2008								
018JAZ	RCFL-H*2417A* ①	18,400 [5.4]	13,200 [3.9]	5,200 [1.5]	11.30	13.00	74	600 [283]
	RCFL-A*2414B*	18,400 [5.4]	13,200 [3.9]	5,200 [1.5]	11.30	13.00	74	600 [283]
	RCFL-A*2417B*	18,400 [5.4]	13,200 [3.9]	5,200 [1.5]	11.30	13.00	74	600 [283]
	RCFL-A*2417B* (RGFD-06?MCK?)	18,800 [5.5]	13,500 [4.0]	5,300 [1.6]	12.50	14.00	74	600 [283]
	RCFL-A*2417B* (RGFD-07?MCK?)	18,800 [5.5]	13,500 [4.0]	5,300 [1.6]	12.50	14.00	74	600 [283]
	RCFL-A*2417B* (RGGD-06?MCK?)	18,900 [5.5]	13,550 [4.0]	5,350 [1.6]	12.65	14.50	74	600 [283]
	RCFL-A*2417B* (RGGD-07?MCK?)	18,900 [5.5]	13,550 [4.0]	5,350 [1.6]	12.55	14.00	74	625 [295]
	RCFL-A*2417B* (RGLR-07?AMK?)	18,900 [5.5]	13,550 [4.0]	5,350 [1.6]	12.70	14.50	74	600 [283]
	RCFL-A*2417B* (RGPR-05?BMK?)	18,800 [5.5]	13,500 [4.0]	5,300 [1.6]	12.40	14.00	74	600 [283]
	RCFL-A*2417B* (RGPR-07?AMK?)	18,900 [5.5]	13,550 [4.0]	5,350 [1.6]	12.65	14.50	74	600 [283]
	RCFL-H*2414A*	18,400 [5.4]	13,200 [3.9]	5,200 [1.5]	11.30	13.00	74	600 [283]
	RCFL-H*2417A* (RGFD-06?MCK?)	18,800 [5.5]	13,500 [4.0]	5,300 [1.6]	12.50	14.00	74	600 [283]
	RCFL-H*2417A* (RGFD-07?MCK?)	18,800 [5.5]	13,500 [4.0]	5,300 [1.6]	12.50	14.00	74	600 [283]
	RCFL-H*2417A* (RGGD-06?MCK?)	18,900 [5.5]	13,550 [4.0]	5,350 [1.6]	12.65	14.50	74	600 [283]
	RCFL-H*2417A* (RGGD-07?MCK?)	18,900 [5.5]	13,550 [4.0]	5,350 [1.6]	12.55	14.00	74	625 [295]
	RCFL-H*2417A* (RGJD-06?MCK?)	18,900 [5.5]	13,550 [4.0]	5,350 [1.6]	12.65	14.50	74	600 [283]
	RCFL-H*2417A* (RGJD-07?MCK?)	18,900 [5.5]	13,550 [4.0]	5,350 [1.6]	12.55	14.00	74	625 [295]
	RCFL-H*2417A* (RGLR-07?AMK?)	18,900 [5.5]	13,550 [4.0]	5,350 [1.6]	12.70	14.50	74	600 [283]
	RCFL-H*2417A* (RGPR-05?BMK?)	18,800 [5.5]	13,500 [4.0]	5,300 [1.6]	12.40	14.00	74	600 [283]
	RCFL-H*2417A* (RGPR-07?AMK?)	18,900 [5.5]	13,550 [4.0]	5,350 [1.6]	12.65	14.50	74	600 [283]
	RBHP-17 (RCHL-24A2)	18,500 [5.4]	13,000 [3.8]	5,500 [1.6]	12.35	14.00	74	650 [307]
	RCHL-24A2 (RGFD-06?MCK?)	18,300 [5.4]	12,800 [3.8]	5,500 [1.6]	12.25	14.00	74	600 [283]
	RCHL-24A2 (RGFD-07?MCK?)	18,300 [5.4]	12,850 [3.8]	5,450 [1.6]	12.25	14.00	74	600 [283]
	RCHL-24A2 (RGGD-06?MCK?)	18,300 [5.4]	12,850 [3.8]	5,450 [1.6]	12.40	14.00	74	600 [283]
	RCHL-24A2 (RGGD-07?MCK?)	18,300 [5.4]	12,850 [3.8]	5,450 [1.6]	12.35	14.00	74	625 [295]
	RCHL-24A2 (RGJD-06?MCK?)	18,300 [5.4]	12,850 [3.8]	5,450 [1.6]	12.40	14.00	74	600 [283]
	RCHL-24A2 (RGJD-07?MCK?)	18,300 [5.4]	12,850 [3.8]	5,450 [1.6]	12.35	14.00	74	625 [295]
	RCHL-24A2 (RGPR-05?BMK?)	18,300 [5.4]	12,800 [3.8]	5,500 [1.6]	12.15	14.00	74	600 [283]
	RCHL-24A2 (RGPR-07?AMK?)	18,300 [5.4]	12,850 [3.8]	5,450 [1.6]	12.40	14.00	74	600 [283]
	RCQD-2417A*	18,700 [5.5]	13,700 [4.0]	5,000 [1.5]	11.20	13.00	74	600 [283]
	RCQD-2417A* (RGFD-06?MCK?)	19,100 [5.6]	14,000 [4.1]	5,100 [1.5]	12.45	14.50	74	600 [283]
	RCQD-2417A* (RGFD-07?MCK?)	19,100 [5.6]	14,000 [4.1]	5,100 [1.5]	12.45	14.50	74	600 [283]
	RCQD-2417A* (RGJD-06?MCK?)	19,200 [5.6]	14,050 [4.1]	5,150 [1.5]	12.60	14.50	74	600 [283]
	RCQD-2417A* (RGJD-07?MCK?)	19,100 [5.6]	14,000 [4.1]	5,100 [1.5]	12.55	14.50	74	625 [295]
RCQD-2417A* (RGPR-05?BMK?)	19,100 [5.6]	14,000 [4.1]	5,100 [1.5]	12.35	14.50	74	600 [283]	
RCQD-2417A* (RGPR-07?AMK?)	19,200 [5.6]	14,050 [4.1]	5,150 [1.5]	12.60	14.50	74	600 [283]	
17AHL124HM (RCSL-H*2417A*)	18,800 [5.5]	13,500 [4.0]	5,300 [1.6]	12.55	14.00	74	600 [283]	
17AHS118HM (RCSL-H*2417A*)	18,600 [5.4]	13,300 [3.9]	5,300 [1.6]	11.70	13.00	74	600 [283]	
RHKL-HM2417 (RCSL-H*2417A*)	19,100 [5.6]	13,750 [4.0]	5,350 [1.6]	12.75	14.50	74	650 [307]	
RHLL-HM2417 (RCSL-H*2417A*)	18,800 [5.5]	13,500 [4.0]	5,300 [1.6]	12.55	14.00	74	600 [283]	
RHSL-HM1817 (RCSL-H*2417A*)	18,600 [5.4]	13,300 [3.9]	5,300 [1.6]	11.70	13.00	74	600 [283]	
024JAZ	RCFL-H*2417A* ①	23,800 [7.0]	16,900 [5.0]	6,900 [2.0]	11.35	13.00	72	800 [378]
	RCFL-A*2414B*	23,800 [7.0]	16,900 [5.0]	6,900 [2.0]	11.35	13.00	72	800 [378]
	RCFL-A*2417B*	23,800 [7.0]	16,900 [5.0]	6,900 [2.0]	11.35	13.00	72	800 [378]
	RCFL-A*2417B* (RGFD-06?MCK?)	24,400 [7.1]	17,350 [5.1]	7,050 [2.1]	12.05	14.00	72	800 [378]
	RCFL-A*2417B* (RGFD-07?MCK?)	24,600 [7.2]	17,400 [5.1]	7,200 [2.1]	12.15	14.00	72	800 [378]
	RCFL-A*2417B* (RGGD-06?MCK?)	24,600 [7.2]	17,450 [5.1]	7,150 [2.1]	12.30	14.00	72	800 [378]
	RCFL-A*2417B* (RGGD-07?MCK?)	24,600 [7.2]	17,450 [5.1]	7,150 [2.1]	12.25	14.00	72	800 [378]
	RCFL-A*2417B* (RGLR-07?AMK?)	24,600 [7.2]	17,500 [5.1]	7,100 [2.1]	12.50	14.00	72	800 [378]
	RCFL-A*2417B* (RGPR-05?BMK?)	24,600 [7.2]	17,400 [5.1]	7,200 [2.1]	12.15	14.00	72	775 [366]
	RCFL-A*2417B* (RGPR-07?AMK?)	24,600 [7.2]	17,500 [5.1]	7,100 [2.1]	12.40	14.00	72	800 [378]
	RCFL-H*2414A*	23,800 [7.0]	16,900 [5.0]	6,900 [2.0]	11.35	13.00	72	800 [378]
	RCFL-H*2417A* (RGFD-06?MCK?)	24,400 [7.1]	17,350 [5.1]	7,050 [2.1]	12.05	14.00	72	800 [378]
	RCFL-H*2417A* (RGFD-07?MCK?)	24,600 [7.2]	17,400 [5.1]	7,200 [2.1]	12.15	14.00	72	800 [378]
	RCFL-H*2417A* (RGGD-06?MCK?)	24,600 [7.2]	17,450 [5.1]	7,150 [2.1]	12.30	14.00	72	800 [378]

① Highest sales volume tested combination required by D.O.E. test procedures.

[ ] Designates Metric Conversions

**Performance Data @ ARI Standard Conditions—Cooling: RANL- (continued)**

Outdoor Unit RANL-	Model Numbers	80°F [26.5°C] DB/67°F [19.5°C] WB Indoor Air 95°F [35°C] DB Outdoor Air					Sound Rating dB	Indoor CFM [L/s]
	Indoor Coil and/or Air Handler	Total Capacity BTU/H [kW]	Net Sensible BTU/H [kW]	Net Latent BTU/H [kW]	EER	SEER		
Revised 9/12/2008								
024JAZ	RCFL-H*2417A* (RGGD-07?MCK?)	24,600 [7.2]	17,450 [5.1]	7,150 [2.1]	12.25	14.00	72	800 [378]
	RCFL-H*2417A* (RGJD-06?MCK?)	24,600 [7.2]	17,450 [5.1]	7,150 [2.1]	12.30	14.00	72	800 [378]
	RCFL-H*2417A* (RGJD-07?MCK?)	24,600 [7.2]	17,450 [5.1]	7,150 [2.1]	12.25	14.00	72	800 [378]
	RCFL-H*2417A* (RGLR-07?AMK?)	24,600 [7.2]	17,500 [5.1]	7,100 [2.1]	12.50	14.00	72	800 [378]
	RCFL-H*2417A* (RGPR-05?BMK?)	24,600 [7.2]	17,400 [5.1]	7,200 [2.1]	12.15	14.00	72	775 [366]
	RCFL-H*2417A* (RGPR-07?AMK?)	24,600 [7.2]	17,500 [5.1]	7,100 [2.1]	12.40	14.00	72	800 [378]
	RCHL-24A2	22,800 [6.7]	15,650 [4.6]	7,150 [2.1]	10.55	13.00	72	800 [378]
	RBHP-17 (RCHL-24A2)	23,400 [6.9]	16,050 [4.7]	7,350 [2.2]	11.65	14.00	72	825 [389]
	RCHL-24A2 (RGFD-06?MCK?)	23,200 [6.8]	16,100 [4.7]	7,100 [2.1]	11.45	14.00	72	800 [378]
	RCHL-24A2 (RGFD-07?MCK?)	23,200 [6.8]	16,150 [4.7]	7,050 [2.1]	11.55	14.00	72	800 [378]
	RCHL-24A2 (RGGD-06?MCK?)	23,400 [6.9]	16,200 [4.7]	7,200 [2.1]	11.75	14.00	72	800 [378]
	RCHL-24A2 (RGGD-07?MCK?)	23,400 [6.9]	16,200 [4.7]	7,200 [2.1]	11.65	14.00	72	800 [378]
	RCHL-24A2 (RGJD-06?MCK?)	23,400 [6.9]	16,200 [4.7]	7,200 [2.1]	11.75	14.00	72	800 [378]
	RCHL-24A2 (RGJD-07?MCK?)	23,400 [6.9]	16,200 [4.7]	7,200 [2.1]	11.65	14.00	72	800 [378]
	RCHL-24A2 (RGLR-07?AMK?)	23,400 [6.9]	16,300 [4.8]	7,100 [2.1]	11.85	14.00	72	800 [378]
	RCHL-24A2 (RGPR-05?BMK?)	23,200 [6.8]	16,150 [4.7]	7,050 [2.1]	11.55	14.00	72	775 [366]
	RCHL-24A2 (RGPR-07?AMK?)	23,400 [6.9]	16,250 [4.8]	7,150 [2.1]	11.80	14.00	72	800 [378]
	RCQD-2417A*	24,600 [7.2]	17,850 [5.2]	6,750 [2.0]	11.20	13.00	72	800 [378]
	RCQD-2417A* (RGFD-06?MCK?)	25,000 [7.3]	18,100 [5.3]	6,900 [2.0]	12.10	14.00	72	800 [378]
	RCQD-2417A* (RGFD-07?MCK?)	25,200 [7.4]	18,300 [5.4]	6,900 [2.0]	12.15	14.50	72	800 [378]
	RCQD-2417A* (RGJD-06?MCK?)	25,200 [7.4]	18,300 [5.4]	6,900 [2.0]	12.35	14.50	72	800 [378]
	RCQD-2417A* (RGJD-07?MCK?)	25,200 [7.4]	18,300 [5.4]	6,900 [2.0]	12.25	14.50	72	800 [378]
	RCQD-2417A* (RGPR-05?BMK?)	25,200 [7.4]	18,300 [5.4]	6,900 [2.0]	12.20	14.50	72	775 [366]
	RCQD-2417A* (RGPR-07?AMK?)	25,200 [7.4]	18,250 [5.3]	6,950 [2.0]	12.40	14.50	72	800 [378]
	17AHL24HM (RCSL-H*2417A*)	24,800 [7.3]	17,600 [5.2]	7,200 [2.1]	12.80	15.00	72	775 [366]
	17AHS24HM (RCSL-H*2417A*)	24,200 [7.1]	17,250 [5.1]	6,950 [2.0]	11.65	13.00	72	800 [378]
	RHKL-HM2417 (RCSL-H*2417A*)	24,800 [7.3]	17,650 [5.2]	7,150 [2.1]	12.45	14.00	72	850 [401]
	RHLL-HM2417 (RCSL-H*2417A*)	24,800 [7.3]	17,600 [5.2]	7,200 [2.1]	12.80	15.00	72	775 [366]
RHSL-HM2417 (RCSL-H*2417A*)	24,200 [7.1]	17,250 [5.1]	6,950 [2.0]	11.65	13.00	72	800 [378]	
031JAZ	RCFL-H*3617A* ①	28,800 [8.4]	21,150 [6.2]	7,650 [2.2]	10.95	13.00	73	1,000 [472]
	RCFL-A*3617B*	28,800 [8.4]	21,150 [6.2]	7,650 [2.2]	10.95	13.00	73	1,000 [472]
	RCFL-A*3617B* (RGFD-07?MCK?)	29,200 [8.6]	21,450 [6.3]	7,750 [2.3]	11.40	13.50	73	1,000 [472]
	RCFL-A*3617B* (RGGD-06?MCK?)	29,200 [8.6]	21,450 [6.3]	7,750 [2.3]	11.45	13.50	73	1,000 [472]
	RCFL-A*3617B* (RGGD-07?MCK?)	29,000 [8.5]	21,300 [6.2]	7,700 [2.3]	11.35	13.50	73	1,025 [484]
	RCFL-A*3617B* (RGLR-07?AMK?)	29,200 [8.6]	21,450 [6.3]	7,750 [2.3]	11.65	13.50	73	1,025 [484]
	RCFL-A*3617B* (RGPR-07?AMK?)	29,200 [8.6]	21,450 [6.3]	7,750 [2.3]	11.65	13.50	73	1,000 [472]
	RCFL-A*3621B*	28,800 [8.4]	21,150 [6.2]	7,650 [2.2]	10.95	13.00	73	1,000 [472]
	RCFL-A*3621B* (RGFD-07?MCK?)	29,200 [8.6]	21,450 [6.3]	7,750 [2.3]	11.45	13.50	73	1,000 [472]
	RCFL-A*3621B* (RGGD-06?MCK?)	29,200 [8.6]	21,450 [6.3]	7,750 [2.3]	11.50	13.50	73	1,000 [472]
	RCFL-A*3621B* (RGGD-07?MCK?)	29,200 [8.6]	21,450 [6.3]	7,750 [2.3]	11.40	13.50	73	1,025 [484]
	RCFL-A*3621B* (RGLR-07?AMK?)	29,200 [8.6]	21,400 [6.3]	7,800 [2.3]	11.70	13.50	73	1,025 [484]
	RCFL-A*3621B* (RGLR-07?BRQ?)	29,400 [8.6]	21,600 [6.3]	7,800 [2.3]	12.00	14.00	73	1,000 [472]
	RCFL-A*3621B* (RGPR-05?BMK?)	29,000 [8.5]	21,250 [6.2]	7,750 [2.3]	11.40	13.50	73	1,000 [472]
	RCFL-A*3621B* (RGPR-07?AMK?)	29,200 [8.6]	21,450 [6.3]	7,750 [2.3]	11.70	13.50	73	1,000 [472]
	RCFL-A*3621B* (RGPR-07?BRQ?)	29,400 [8.6]	21,550 [6.3]	7,850 [2.3]	12.05	14.00	73	1,000 [472]
	RCFL-H*3617A* (RGFD-07?MCK?)	29,200 [8.6]	21,450 [6.3]	7,750 [2.3]	11.40	13.50	73	1,000 [472]
	RCFL-H*3617A* (RGGD-06?MCK?)	29,200 [8.6]	21,450 [6.3]	7,750 [2.3]	11.45	13.50	73	1,000 [472]
	RCFL-H*3617A* (RGGD-07?MCK?)	29,000 [8.5]	21,300 [6.2]	7,700 [2.3]	11.35	13.50	73	1,025 [484]
	RCFL-H*3617A* (RGJD-06?MCK?)	29,200 [8.6]	21,450 [6.3]	7,750 [2.3]	11.45	13.50	73	1,000 [472]
	RCFL-H*3617A* (RGJD-07?MCK?)	29,000 [8.5]	21,300 [6.2]	7,700 [2.3]	11.35	13.50	73	1,025 [484]
	RCFL-H*3617A* (RGLR-07?AMK?)	29,200 [8.6]	21,450 [6.3]	7,750 [2.3]	11.65	13.50	73	1,025 [484]
	RCFL-H*3617A* (RGLR-07?BRQ?)	29,400 [8.6]	21,600 [6.3]	7,800 [2.3]	11.95	14.00	73	1,000 [472]
	RCFL-H*3617A* (RGPR-07?AMK?)	29,200 [8.6]	21,450 [6.3]	7,750 [2.3]	11.65	13.50	73	1,000 [472]
	RCFL-H*3621A*	28,800 [8.4]	21,150 [6.2]	7,650 [2.2]	10.95	13.00	73	1,000 [472]
	RCFL-H*3621A* (RGFD-07?MCK?)	29,200 [8.6]	21,450 [6.3]	7,750 [2.3]	11.45	13.50	73	1,000 [472]

① Highest sales volume tested combination required by D.O.E. test procedures.

[ ] Designates Metric Conversions

**Performance Data @ ARI Standard Conditions—Cooling: RANL- (continued)**

Outdoor Unit RANL-	Model Numbers Indoor Coil and/or Air Handler	80°F [26.5°C] DB/67°F [19.5°C] WB Indoor Air 95°F [35°C] DB Outdoor Air					Sound Rating dB	Indoor CFM [L/s]
		Total Capacity BTU/H [kW]	Net Sensible BTU/H [kW]	Net Latent BTU/H [kW]	EER	SEER		
Revised 9/12/2008								
031JAZ	RCFL-H*3621A* (RGGD-06?MCK?)	29,200 [8.6]	21,450 [6.3]	7,750 [2.3]	11.50	13.50	73	1,000 [472]
	RCFL-H*3621A* (RGGD-07?MCK?)	29,200 [8.6]	21,450 [6.3]	7,750 [2.3]	11.40	13.50	73	1,025 [484]
	RCFL-H*3621A* (RGJD-06?MCK?)	29,200 [8.6]	21,450 [6.3]	7,750 [2.3]	11.50	13.50	73	1,000 [472]
	RCFL-H*3621A* (RGJD-07?MCK?)	29,200 [8.6]	21,450 [6.3]	7,750 [2.3]	11.40	13.50	73	1,025 [484]
	RCFL-H*3621A* (RGLR-07?AMK?)	29,200 [8.6]	21,400 [6.3]	7,800 [2.3]	11.70	13.50	73	1,025 [484]
	RCFL-H*3621A* (RGLR-07?BRQ?)	29,400 [8.6]	21,600 [6.3]	7,800 [2.3]	12.00	14.00	73	1,000 [472]
	RCFL-H*3621A* (RGPR-05?BMK?)	29,000 [8.5]	21,250 [6.2]	7,750 [2.3]	11.40	13.50	73	1,000 [472]
	RCFL-H*3621A* (RGPR-07?AMK?)	29,200 [8.6]	21,450 [6.3]	7,750 [2.3]	11.70	13.50	73	1,000 [472]
	RCFL-H*3621A* (RGPR-07?BRQ?)	29,400 [8.6]	21,550 [6.3]	7,850 [2.3]	12.05	14.00	73	1,000 [472]
	RBHP-21 (RCHL-36A1)	29,600 [8.7]	21,150 [6.2]	8,450 [2.5]	12.10	14.00	73	1,050 [495]
	RCHL-36A1 (RGFD-06?MCK?)	28,800 [8.4]	20,300 [5.9]	8,500 [2.5]	11.20	13.00	73	1,000 [472]
	RCHL-36A1 (RGFD-07?MCK?)	29,000 [8.5]	20,450 [6.0]	8,550 [2.5]	11.40	13.50	73	1,000 [472]
	RCHL-36A1 (RGGD-06?MCK?)	29,000 [8.5]	20,450 [6.0]	8,550 [2.5]	11.50	13.50	73	1,000 [472]
	RCHL-36A1 (RGGD-07?MCK?)	29,000 [8.5]	20,450 [6.0]	8,550 [2.5]	11.45	13.50	73	1,025 [484]
	RCHL-36A1 (RGJD-06?MCK?)	29,000 [8.5]	20,450 [6.0]	8,550 [2.5]	11.50	13.50	73	1,000 [472]
	RCHL-36A1 (RGJD-07?MCK?)	29,000 [8.5]	20,450 [6.0]	8,550 [2.5]	11.45	13.50	73	1,025 [484]
	RCHL-36A1 (RGLR-07?AMK?)	29,200 [8.6]	20,600 [6.0]	8,600 [2.5]	11.70	14.00	73	1,025 [484]
	RCHL-36A1 (RGLR-07?BRQ?)	29,200 [8.6]	20,550 [6.0]	8,650 [2.5]	12.00	14.00	73	1,000 [472]
	RCHL-36A1 (RGPR-05?BMK?)	29,000 [8.5]	20,450 [6.0]	8,550 [2.5]	11.35	13.50	73	1,000 [472]
	RCHL-36A1 (RGPR-07?AMK?)	29,000 [8.5]	20,400 [6.0]	8,600 [2.5]	11.65	14.00	73	1,000 [472]
	RCHL-36A1 (RGPR-07?BRQ?)	29,200 [8.6]	20,550 [6.0]	8,650 [2.5]	12.00	14.00	73	1,000 [472]
	RCQD-3621A* (RGFD-06?MCK?)	30,400 [8.9]	22,650 [6.6]	7,750 [2.3]	11.70	13.50	73	1,000 [472]
	RCQD-3621A* (RGFD-07?MCK?)	30,600 [9.0]	22,800 [6.7]	7,800 [2.3]	11.90	14.00	73	1,000 [472]
	RCQD-3621A* (RGJD-06?MCK?)	30,600 [9.0]	22,800 [6.7]	7,800 [2.3]	12.00	14.00	73	1,000 [472]
	RCQD-3621A* (RGJD-07?MCK?)	30,600 [9.0]	22,800 [6.7]	7,800 [2.3]	11.95	14.00	73	1,025 [484]
	RCQD-3621A* (RGPR-05?BMK?)	30,600 [9.0]	22,800 [6.7]	7,800 [2.3]	11.90	14.00	73	1,000 [472]
	RCQD-3621A* (RGPR-07?AMK?)	30,800 [9.0]	23,000 [6.7]	7,800 [2.3]	12.20	14.00	73	1,000 [472]
	RCQD-3621A* (RGPR-07?BRQ?)	31,000 [9.1]	23,150 [6.8]	7,850 [2.3]	12.55	14.00	73	1,000 [472]
	17AHSL30AU (RCSL-A*3617B*)	28,800 [8.4]	20,900 [6.1]	7,900 [2.3]	11.20	13.00	73	950 [448]
	17AHLL36HM (RCSL-H*3617A*)	29,400 [8.6]	21,550 [6.3]	7,850 [2.3]	12.05	14.00	73	1,000 [472]
	17AHSL30HM (RCSL-H*3617A*)	28,800 [8.4]	20,900 [6.1]	7,900 [2.3]	11.20	13.00	73	950 [448]
	RHKL-HM3617 (RCSL-H*3617A*)	29,400 [8.6]	21,600 [6.3]	7,800 [2.3]	11.90	14.00	73	1,025 [484]
RHLL-HM3617 (RCSL-H*3617A*)	29,400 [8.6]	21,550 [6.3]	7,850 [2.3]	12.05	14.00	73	1,000 [472]	
RHSL-HM3017 (RCSL-H*3617A*)	28,800 [8.4]	20,900 [6.1]	7,900 [2.3]	11.20	13.00	73	950 [448]	
037CAZ/ DAZ/JAZ	RCFL-H*3617A* ①	37,600 [11.0]	25,750 [7.5]	11,850 [3.5]	11.20	13.00	76	1,050 [495]
	RCFL-A*3617B*	37,600 [11.0]	25,750 [7.5]	11,850 [3.5]	11.20	13.00	76	1,050 [495]
	RCFL-A*3617B* (RGGD-07?MCK?)	37,800 [11.1]	25,900 [7.6]	11,900 [3.5]	11.60	13.50	76	1,025 [484]
	RCFL-A*3621B*	37,600 [11.0]	25,750 [7.5]	11,850 [3.5]	11.20	13.00	76	1,050 [495]
	RCFL-A*3621B* (RGFD-09?ZCM?)	38,500 [11.3]	27,050 [7.9]	11,450 [3.4]	11.70	13.50	76	1,150 [543]
	RCFL-A*3621B* (RGFD-10?ZCM?)	38,500 [11.3]	27,150 [8.0]	11,350 [3.3]	11.55	13.50	76	1,175 [554]
	RCFL-A*3621B* (RGGD-07?MCK?)	37,800 [11.1]	25,850 [7.6]	11,950 [3.5]	11.65	13.50	76	1,025 [484]
	RCFL-A*3621B* (RGGD-09?ZCM?)	38,500 [11.3]	27,150 [8.0]	11,350 [3.3]	11.70	13.50	76	1,175 [554]
	RCFL-A*3621B* (RGGD-10?ZCM?)	38,500 [11.3]	27,150 [8.0]	11,350 [3.3]	11.75	13.50	76	1,175 [554]
	RCFL-A*3621B* (RGLR-07?AMK?)	38,000 [11.1]	26,000 [7.6]	12,000 [3.5]	11.85	13.50	76	1,025 [484]
	RCFL-A*3621B* (RGLR-10?BRM?)	39,000 [11.4]	27,700 [8.1]	11,300 [3.3]	11.90	13.50	76	1,200 [566]
	RCFL-A*3621B* (RGPR-07?BRQ?)	39,000 [11.4]	27,700 [8.1]	11,300 [3.3]	11.90	13.50	76	1,200 [566]
	RCFL-H*3617A* (RGGD-07?MCK?)	37,800 [11.1]	25,900 [7.6]	11,900 [3.5]	11.60	13.50	76	1,025 [484]
	RCFL-H*3617A* (RGJD-07?MCK?)	37,800 [11.1]	25,900 [7.6]	11,900 [3.5]	11.60	13.50	76	1,025 [484]
	RCFL-H*3617A* (RGLR-07?AMK?)	38,000 [11.1]	26,050 [7.6]	11,950 [3.5]	11.85	13.50	76	1,025 [484]
	RCFL-H*3621A*	37,600 [11.0]	25,750 [7.5]	11,850 [3.5]	11.20	13.00	76	1,050 [495]
	RCFL-H*3621A* (RGFD-09?ZCM?)	38,500 [11.3]	27,050 [7.9]	11,450 [3.4]	11.70	13.50	76	1,150 [543]
	RCFL-H*3621A* (RGFD-10?ZCM?)	38,500 [11.3]	27,150 [8.0]	11,350 [3.3]	11.55	13.50	76	1,175 [554]
	RCFL-H*3621A* (RGGD-07?MCK?)	37,800 [11.1]	25,850 [7.6]	11,950 [3.5]	11.65	13.50	76	1,025 [484]
	RCFL-H*3621A* (RGGD-09?ZCM?)	38,500 [11.3]	27,150 [8.0]	11,350 [3.3]	11.70	13.50	76	1,175 [554]
RCFL-H*3621A* (RGGD-10?ZCM?)	38,500 [11.3]	27,150 [8.0]	11,350 [3.3]	11.75	13.50	76	1,175 [554]	

① Highest sales volume tested combination required by D.O.E. test procedures.

[ ] Designates Metric Conversions

**Performance Data @ ARI Standard Conditions—Cooling: RANL- (continued)**

Outdoor Unit RANL-	Model Numbers Indoor Coil and/or Air Handler	80°F [26.5°C] DB/67°F [19.5°C] WB Indoor Air 95°F [35°C] DB Outdoor Air					Sound Rating dB	Indoor CFM [L/s]
		Total Capacity BTU/H [kW]	Net Sensible BTU/H [kW]	Net Latent BTU/H [kW]	EER	SEER		
Revised 9/12/2008								
037CAZ/ DAZ/JAZ	RCFL-H*3621A* (RGJD-07?MCK?)	37,800 [11.1]	25,850 [7.6]	11,950 [3.5]	11.65	13.50	76	1,025 [484]
	RCFL-H*3621A* (RGJD-09?ZCM?)	38,500 [11.3]	27,150 [8.0]	11,350 [3.3]	11.70	13.50	76	1,175 [554]
	RCFL-H*3621A* (RGJD-10?ZCM?)	38,500 [11.3]	27,150 [8.0]	11,350 [3.3]	11.75	13.50	76	1,175 [554]
	RCFL-H*3621A* (RGLR-07?AMK?)	38,000 [11.1]	26,000 [7.6]	12,000 [3.5]	11.85	13.50	76	1,025 [484]
	RCFL-H*3621A* (RGLR-10?BRM?)	39,000 [11.4]	27,700 [8.1]	11,300 [3.3]	11.90	13.50	76	1,200 [566]
	RCFL-H*3621A* (RGPR-07?AMK?)	38,500 [11.3]	27,300 [8.0]	11,200 [3.3]	11.45	13.00	76	1,200 [566]
	RCFL-H*3621A* (RGPR-07?BRQ?)	39,000 [11.4]	27,700 [8.1]	11,300 [3.3]	11.90	13.50	76	1,200 [566]
	RBHP-21 (RCHL-36A1)	38,000 [11.1]	25,800 [7.6]	12,200 [3.6]	11.70	14.00	76	1,225 [578]
	RCHL-36A1 (RGFD-09?ZCM?)	37,600 [11.0]	25,200 [7.4]	12,400 [3.6]	11.50	13.50	76	1,150 [543]
	RCHL-36A1 (RGFD-10?ZCM?)	37,800 [11.1]	25,650 [7.5]	12,150 [3.6]	11.45	13.50	76	1,175 [554]
	RCHL-36A1 (RGGD-06?MCK?)	37,600 [11.0]	25,550 [7.5]	12,050 [3.5]	10.95	13.00	76	1,225 [578]
	RCHL-36A1 (RGGD-09?ZCM?)	38,000 [11.1]	25,800 [7.6]	12,200 [3.6]	11.55	13.50	76	1,175 [554]
	RCHL-36A1 (RGGD-10?ZCM?)	38,000 [11.1]	25,800 [7.6]	12,200 [3.6]	11.55	13.50	76	1,175 [554]
	RCHL-36A1 (RGJD-06?MCK?)	37,600 [11.0]	25,550 [7.5]	12,050 [3.5]	10.95	13.00	76	1,225 [578]
	RCHL-36A1 (RGJD-09?ZCM?)	38,000 [11.1]	25,800 [7.6]	12,200 [3.6]	11.55	13.50	76	1,175 [554]
	RCHL-36A1 (RGJD-10?ZCM?)	38,000 [11.1]	25,800 [7.6]	12,200 [3.6]	11.55	13.50	76	1,175 [554]
	RCHL-36A1 (RGLR-07?AMK?)	37,800 [11.1]	25,650 [7.5]	12,150 [3.6]	11.30	13.50	76	1,200 [566]
	RCHL-36A1 (RGLR-07?BRQ?)	38,000 [11.1]	25,800 [7.6]	12,200 [3.6]	11.65	14.00	76	1,225 [578]
	RCHL-36A1 (RGLR-10?BRM?)	38,000 [11.1]	25,800 [7.6]	12,200 [3.6]	11.70	14.00	76	1,200 [566]
	RCHL-36A1 (RGPR-07?AMK?)	37,800 [11.1]	25,700 [7.5]	12,100 [3.5]	11.30	13.50	76	1,200 [566]
	RCHL-36A1 (RGPR-07?BRQ?)	38,000 [11.1]	25,800 [7.6]	12,200 [3.6]	11.70	14.00	76	1,200 [566]
	RCHL-36A1 (RGPR-10?BRM?)	38,000 [11.1]	25,800 [7.6]	12,200 [3.6]	11.55	13.50	76	1,225 [578]
	RCQD-3621A*	38,500 [11.3]	27,450 [8.0]	11,050 [3.2]	11.05	13.00	76	1,200 [566]
	RCQD-3621A* (RGFD-09?ZCM?)	39,500 [11.6]	27,800 [8.1]	11,700 [3.4]	11.95	14.00	76	1,150 [543]
	RCQD-3621A* (RGFD-10?ZCM?)	40,000 [11.7]	28,550 [8.4]	11,450 [3.4]	11.90	14.00	76	1,175 [554]
	RCQD-3621A* (RGJD-06?MCK?)	39,500 [11.6]	28,200 [8.3]	11,300 [3.3]	11.40	13.50	76	1,225 [578]
	RCQD-3621A* (RGJD-09?ZCM?)	40,000 [11.7]	28,550 [8.4]	11,450 [3.4]	12.00	14.00	76	1,175 [554]
	RCQD-3621A* (RGJD-10?ZCM?)	40,000 [11.7]	28,550 [8.4]	11,450 [3.4]	12.05	14.00	76	1,175 [554]
	RCQD-3621A* (RGPR-05?BMK?)	39,500 [11.6]	28,200 [8.3]	11,300 [3.3]	11.35	13.50	76	1,200 [566]
	RCQD-3621A* (RGPR-07?AMK?)	40,000 [11.7]	28,600 [8.4]	11,400 [3.3]	11.75	13.50	76	1,200 [566]
	RCQD-3621A* (RGPR-07?BRQ?)	40,000 [11.7]	28,500 [8.4]	11,500 [3.4]	12.15	14.00	76	1,200 [566]
	RCQD-3621A* (RGPR-10?BRM?)	40,000 [11.7]	28,550 [8.4]	11,450 [3.4]	12.00	14.00	76	1,225 [578]
	RCQD-3624A*	38,500 [11.3]	27,450 [8.0]	11,050 [3.2]	11.05	13.00	76	1,200 [566]
	RCQD-3624A* (RGFD-09?ZCM?)	39,500 [11.6]	27,800 [8.1]	11,700 [3.4]	11.95	14.00	76	1,150 [543]
	RCQD-3624A* (RGFD-10?ZCM?)	40,000 [11.7]	28,550 [8.4]	11,450 [3.4]	11.90	14.00	76	1,175 [554]
	RCQD-3624A* (RGFD-12?RCM?)	40,000 [11.7]	28,550 [8.4]	11,450 [3.4]	11.95	14.00	76	1,225 [578]
	RCQD-3624A* (RGJD-07?MCK?)	39,500 [11.6]	28,200 [8.3]	11,300 [3.3]	11.30	13.00	76	1,225 [578]
	RCQD-3624A* (RGJD-09?ZCM?)	40,000 [11.7]	28,550 [8.4]	11,450 [3.4]	12.00	14.00	76	1,175 [554]
	RCQD-3624A* (RGJD-10?ZCM?)	40,000 [11.7]	28,550 [8.4]	11,450 [3.4]	12.05	14.00	76	1,175 [554]
	RCQD-3624A* (RGJD-12?RCM?)	40,000 [11.7]	28,550 [8.4]	11,450 [3.4]	12.10	14.00	76	1,225 [578]
	RCQD-3624A* (RGPR-05?BMK?)	39,500 [11.6]	28,200 [8.3]	11,300 [3.3]	11.35	13.50	76	1,200 [566]
	RCQD-3624A* (RGPR-07?AMK?)	40,000 [11.7]	28,600 [8.4]	11,400 [3.3]	11.75	13.50	76	1,200 [566]
RCQD-3624A* (RGPR-07?BRQ?)	40,000 [11.7]	28,500 [8.4]	11,500 [3.4]	12.15	14.00	76	1,200 [566]	
RCQD-3624A* (RGPR-10?BRM?)	40,000 [11.7]	28,550 [8.4]	11,450 [3.4]	12.00	14.00	76	1,225 [578]	
RCQD-3624A* (RGPR-12?ARM?)	40,500 [11.9]	29,300 [8.6]	11,200 [3.3]	12.15	14.00	76	1,250 [590]	
17AHSL36AU (RCSL-A*3617B*)	37,800 [11.1]	26,200 [7.7]	11,600 [3.4]	11.20	13.00	76	1,100 [519]	
17AHLL36HM (RCSL-H*3617A*)	39,000 [11.4]	27,700 [8.1]	11,300 [3.3]	11.95	14.00	76	1,200 [566]	
17AHSL36HM (RCSL-H*3617A*)	37,800 [11.1]	26,200 [7.7]	11,600 [3.4]	11.20	13.00	76	1,100 [519]	
RHKL-HM3617 (RCSL-H*3617A*)	39,000 [11.4]	27,700 [8.1]	11,300 [3.3]	11.95	14.00	76	1,200 [566]	
RHLL-HM3617 (RCSL-H*3617A*)	39,000 [11.4]	27,700 [8.1]	11,300 [3.3]	11.95	14.00	76	1,200 [566]	
RHSL-HM3617 (RCSL-H*3617A*)	37,800 [11.1]	26,200 [7.7]	11,600 [3.4]	11.20	13.00	76	1,100 [519]	
RHSL-HM3621 (RCSL-H*3621A*)	37,800 [11.1]	26,200 [7.7]	11,600 [3.4]	11.20	13.00	76	1,100 [519]	
043CAZ/ DAZ/JAZ	RCSL-H*4821A* ①	41,500 [12.2]	29,700 [8.7]	11,800 [3.5]	10.90	13.00	76	1,400 [661]
	RCFL-A*4821B*	41,500 [12.2]	29,700 [8.7]	11,800 [3.5]	10.90	13.00	76	1,400 [661]
	RCFL-A*4821B* (RGLR-07?BRQ?)	42,000 [12.3]	30,100 [8.8]	11,900 [3.5]	11.40	13.50	76	1,425 [672]

① Highest sales volume tested combination required by D.O.E. test procedures.

[ ] Designates Metric Conversions

**Performance Data @ ARI Standard Conditions—Cooling: RANL- (continued)**

Outdoor Unit RANL-	Model Numbers Indoor Coil and/or Air Handler	80°F [26.5°C] DB/67°F [19.5°C] WB Indoor Air 95°F [35°C] DB Outdoor Air					Sound Rating dB	Indoor CFM [L/s]
		Total Capacity BTU/H [kW]	Net Sensible BTU/H [kW]	Net Latent BTU/H [kW]	EER	SEER		
Revised 9/12/2008								
043CAZ/ DAZ/JAZ	RCFL-A*4821B* (RGLR-10?BRM?)	42,000 [12.3]	30,050 [8.8]	11,950 [3.5]	11.55	13.50	76	1,375 [649]
	RCFL-A*4821B* (RGPR-07?BRQ?)	42,000 [12.3]	30,050 [8.8]	11,950 [3.5]	11.50	13.50	76	1,400 [661]
	RCFL-A*4824B*	41,500 [12.2]	29,700 [8.7]	11,800 [3.5]	10.90	13.00	76	1,400 [661]
	RCFL-A*4824B* (RGGD-12?RCM?)	42,000 [12.3]	30,400 [8.9]	11,600 [3.4]	11.40	13.50	76	1,450 [684]
	RCFL-A*4824B* (RGLR-07?BRQ?)	42,000 [12.3]	30,100 [8.8]	11,900 [3.5]	11.40	13.50	76	1,425 [672]
	RCFL-A*4824B* (RGLR-10?BRM?)	42,000 [12.3]	30,050 [8.8]	11,950 [3.5]	11.55	13.50	76	1,375 [649]
	RCFL-A*4824B* (RGLR-12?ARM?)	42,000 [12.3]	30,050 [8.8]	11,950 [3.5]	11.50	13.50	76	1,425 [672]
	RCFL-A*4824B* (RGPR-07?BRQ?)	42,000 [12.3]	30,050 [8.8]	11,950 [3.5]	11.50	13.50	76	1,400 [661]
	RCFL-A*4824B* (RGPR-12?ARM?)	42,000 [12.3]	30,050 [8.8]	11,950 [3.5]	11.50	13.50	76	1,400 [661]
	RCFL-H*4821A* (RGLR-07?BRQ?)	42,000 [12.3]	30,100 [8.8]	11,900 [3.5]	11.40	13.50	76	1,425 [672]
	RCFL-H*4821A* (RGLR-10?BRM?)	42,000 [12.3]	30,050 [8.8]	11,950 [3.5]	11.55	13.50	76	1,375 [649]
	RCFL-H*4821A* (RGPR-07?BRQ?)	42,000 [12.3]	30,050 [8.8]	11,950 [3.5]	11.50	13.50	76	1,400 [661]
	RCFL-H*4824A*	41,500 [12.2]	29,700 [8.7]	11,800 [3.5]	10.90	13.00	76	1,400 [661]
	RCFL-H*4824A* (RGGD-12?RCM?)	42,000 [12.3]	30,400 [8.9]	11,600 [3.4]	11.40	13.50	76	1,450 [684]
	RCFL-H*4824A* (RGJD-12?RCM?)	42,000 [12.3]	30,400 [8.9]	11,600 [3.4]	11.40	13.50	76	1,450 [684]
	RCFL-H*4824A* (RGLR-07?BRQ?)	42,000 [12.3]	30,100 [8.8]	11,900 [3.5]	11.40	13.50	76	1,425 [672]
	RCFL-H*4824A* (RGLR-10?BRM?)	42,000 [12.3]	30,050 [8.8]	11,950 [3.5]	11.55	13.50	76	1,375 [649]
	RCFL-H*4824A* (RGLR-12?ARM?)	42,000 [12.3]	30,050 [8.8]	11,950 [3.5]	11.50	13.50	76	1,425 [672]
	RCFL-H*4824A* (RGPR-07?BRQ?)	42,000 [12.3]	30,050 [8.8]	11,950 [3.5]	11.50	13.50	76	1,400 [661]
	RCFL-H*4824A* (RGPR-12?ARM?)	42,000 [12.3]	30,050 [8.8]	11,950 [3.5]	11.50	13.50	76	1,400 [661]
	RBHP-24 (RCHL-48A1)	41,000 [12.0]	28,100 [8.2]	12,900 [3.8]	11.55	14.00	76	1,400 [661]
	RCHL-48A1 (RGFD-09?ZCM?)	40,000 [11.7]	26,900 [7.9]	13,100 [3.8]	10.90	13.00	76	1,325 [625]
	RCHL-48A1 (RGFD-10?ZCM?)	40,000 [11.7]	26,950 [7.9]	13,050 [3.8]	10.75	13.00	76	1,325 [625]
	RCHL-48A1 (RGFD-12?RCM?)	40,500 [11.9]	28,200 [8.3]	12,300 [3.6]	10.90	13.00	76	1,475 [696]
	RCHL-48A1 (RGGD-09?ZCM?)	40,500 [11.9]	27,800 [8.1]	12,700 [3.7]	10.90	13.00	76	1,425 [672]
	RCHL-48A1 (RGGD-10?ZCM?)	40,500 [11.9]	27,800 [8.1]	12,700 [3.7]	10.90	13.00	76	1,425 [672]
	RCHL-48A1 (RGGD-12?RCM?)	40,500 [11.9]	28,000 [8.2]	12,500 [3.7]	11.10	13.50	76	1,450 [684]
	RCHL-48A1 (RGJD-09?ZCM?)	40,500 [11.9]	27,800 [8.1]	12,700 [3.7]	10.90	13.00	76	1,425 [672]
	RCHL-48A1 (RGJD-10?ZCM?)	40,500 [11.9]	27,800 [8.1]	12,700 [3.7]	10.90	13.00	76	1,425 [672]
	RCHL-48A1 (RGJD-12?RCM?)	40,500 [11.9]	28,000 [8.2]	12,500 [3.7]	11.10	13.50	76	1,450 [684]
	RCHL-48A1 (RGLR-07?BRQ?)	40,500 [11.9]	27,700 [8.1]	12,800 [3.8]	11.15	13.00	76	1,425 [672]
	RCHL-48A1 (RGLR-10?BRM?)	40,500 [11.9]	27,700 [8.1]	12,800 [3.8]	11.25	13.50	76	1,375 [649]
	RCHL-48A1 (RGLR-12?ARM?)	40,500 [11.9]	27,700 [8.1]	12,800 [3.8]	11.20	13.50	76	1,425 [672]
	RCHL-48A1 (RGPR-07?BRQ?)	40,500 [11.9]	27,700 [8.1]	12,800 [3.8]	11.20	13.50	76	1,400 [661]
	RCHL-48A1 (RGPR-10?BRM?)	40,500 [11.9]	27,750 [8.1]	12,750 [3.7]	11.00	13.00	76	1,425 [672]
	RCHL-48A1 (RGPR-12?ARM?)	40,500 [11.9]	27,700 [8.1]	12,800 [3.8]	11.20	13.50	76	1,400 [661]
	RCQD-4821A* (RGFD-09?ZCM?)	42,000 [12.3]	29,800 [8.7]	12,200 [3.6]	11.30	13.00	76	1,325 [625]
	RCQD-4821A* (RGFD-10?ZCM?)	42,000 [12.3]	29,850 [8.7]	12,150 [3.6]	11.15	13.00	76	1,325 [625]
	RCQD-4821A* (RGJD-09?ZCM?)	42,500 [12.5]	30,750 [9.0]	11,750 [3.4]	11.25	13.00	76	1,425 [672]
	RCQD-4821A* (RGJD-10?ZCM?)	42,500 [12.5]	30,750 [9.0]	11,750 [3.4]	11.30	13.00	76	1,425 [672]
	RCQD-4821A* (RGJD-12?RCM?)	43,000 [12.6]	31,500 [9.2]	11,500 [3.4]	11.50	13.50	76	1,450 [684]
	RCQD-4821A* (RGPR-07?BRQ?)	42,500 [12.5]	30,650 [9.0]	11,850 [3.5]	11.60	13.50	76	1,400 [661]
	RCQD-4821A* (RGPR-10?BRM?)	42,500 [12.5]	30,700 [9.0]	11,800 [3.5]	11.40	13.50	76	1,425 [672]
	RCQD-4824A* (RGFD-09?ZCM?)	42,000 [12.3]	29,800 [8.7]	12,200 [3.6]	11.40	13.50	76	1,325 [625]
	RCQD-4824A* (RGFD-10?ZCM?)	42,000 [12.3]	29,800 [8.7]	12,200 [3.6]	11.25	13.00	76	1,325 [625]
	RCQD-4824A* (RGFD-12?RCM?)	43,000 [12.6]	31,650 [9.3]	11,350 [3.3]	11.35	13.50	76	1,475 [696]
	RCQD-4824A* (RGJD-09?ZCM?)	42,500 [12.5]	30,700 [9.0]	11,800 [3.5]	11.35	13.50	76	1,425 [672]
	RCQD-4824A* (RGJD-10?ZCM?)	42,500 [12.5]	30,700 [9.0]	11,800 [3.5]	11.35	13.50	76	1,425 [672]
	RCQD-4824A* (RGJD-12?RCM?)	43,000 [12.6]	31,450 [9.2]	11,550 [3.4]	11.60	13.50	76	1,450 [684]
	RCQD-4824A* (RGPR-07?BRQ?)	43,000 [12.6]	31,150 [9.1]	11,850 [3.5]	11.70	13.50	76	1,400 [661]
RCQD-4824A* (RGPR-10?BRM?)	42,500 [12.5]	30,700 [9.0]	11,800 [3.5]	11.50	13.50	76	1,425 [672]	
RCQD-4824A* (RGPR-12?ARM?)	43,000 [12.6]	31,150 [9.1]	11,850 [3.5]	11.70	13.50	76	1,400 [661]	
21AHSL42AU (RCSL-H*4821A*)	41,000 [12.0]	28,950 [8.5]	12,050 [3.5]	10.85	13.00	76	1,350 [637]	
21AHSL42HM (RCSL-H*4821A*)	41,000 [12.0]	28,950 [8.5]	12,050 [3.5]	10.85	13.00	76	1,350 [637]	
RHKL-HM4821 (RCSL-H*4821A*)	42,000 [12.3]	30,000 [8.8]	12,000 [3.5]	11.70	13.50	76	1,400 [661]	

① Highest sales volume tested combination required by D.O.E. test procedures.

[ ] Designates Metric Conversions

**Performance Data @ ARI Standard Conditions—Cooling: RANL- (continued)**

Outdoor Unit RANL-	Model Numbers Indoor Coil and/or Air Handler	80°F [26.5°C] DB/67°F [19.5°C] WB Indoor Air 95°F [35°C] DB Outdoor Air					Sound Rating dB	Indoor CFM [L/s]
		Total Capacity BTU/H [kW]	Net Sensible BTU/H [kW]	Net Latent BTU/H [kW]	EER	SEER		
Revised 9/12/2008								
043CAZ/ DAZ/JAZ	RHLL-HM4821 (RCSL-H*4821A*)	42,000 [12.3]	30,000 [8.8]	12,000 [3.5]	11.75	14.00	76	1,400 [661]
	RHSL-HM4221 (RCSL-H*4821A*)	41,000 [12.0]	28,950 [8.5]	12,050 [3.5]	10.85	13.00	76	1,350 [637]
049CAZ/ DAZ/JAZ/YAZ	RCFL-H*4821A* ①	46,500 [13.6]	33,250 [9.7]	13,250 [3.9]	11.05	13.00	76	1,550 [731]
	RCFL-A*4821B*	46,500 [13.6]	33,250 [9.7]	13,250 [3.9]	11.05	13.00	76	1,550 [731]
	RCFL-A*4824B*	46,500 [13.6]	33,250 [9.7]	13,250 [3.9]	11.05	13.00	76	1,550 [731]
	RCFL-H*4824A*	46,500 [13.6]	33,250 [9.7]	13,250 [3.9]	11.05	13.00	76	1,550 [731]
	RBHP-24 (RCHL-48A1)	45,500 [13.3]	31,300 [9.2]	14,200 [4.2]	11.40	13.00	76	1,600 [755]
	RCHL-48A1 (RGLR-07?BRQ?)	45,000 [13.2]	30,950 [9.1]	14,050 [4.1]	10.95	13.00	76	1,625 [767]
	RCHL-48A1 (RGLR-10?BRM?)	45,000 [13.2]	30,950 [9.1]	14,050 [4.1]	11.00	13.00	76	1,575 [743]
	RCHL-48A1 (RGLR-12?ARM?)	45,000 [13.2]	30,900 [9.1]	14,100 [4.1]	11.10	13.00	76	1,600 [755]
	RCHL-48A1 (RGPR-07?BRQ?)	45,000 [13.2]	30,950 [9.1]	14,050 [4.1]	11.00	13.00	76	1,625 [767]
	RCHL-48A1 (RGPR-12?ARM?)	45,000 [13.2]	30,900 [9.1]	14,100 [4.1]	11.05	13.00	76	1,575 [743]
	21AHLL48HM (RCSL-H*4821A*)	47,000 [13.8]	33,950 [9.9]	13,050 [3.8]	11.65	13.50	76	1,600 [755]
	21AHSL48AU (RCSL-H*4821A*)	46,500 [13.6]	33,250 [9.7]	13,250 [3.9]	11.15	13.00	76	1,525 [720]
	21AHSL48HM (RCSL-H*4821A*)	46,500 [13.6]	33,250 [9.7]	13,250 [3.9]	11.15	13.00	76	1,525 [720]
	RHKL-HM4821 (RCSL-H*4821A*)	47,000 [13.8]	33,650 [9.9]	13,350 [3.9]	11.55	13.50	76	1,575 [743]
	RHLL-HM4821 (RCSL-H*4821A*)	47,000 [13.8]	33,950 [9.9]	13,050 [3.8]	11.65	13.50	76	1,600 [755]
	RHSL-HM4821 (RCSL-H*4821A*)	46,500 [13.6]	33,250 [9.7]	13,250 [3.9]	11.15	13.00	76	1,525 [720]
	24AHLL48HM (RCSL-H*4824A*)	48,500 [14.2]	36,450 [10.7]	12,050 [3.5]	12.15	14.00	76	1,625 [767]
	24AHSL48AU (RCSL-H*4824A*)	47,500 [13.9]	35,000 [10.3]	12,500 [3.7]	11.30	13.00	76	1,525 [720]
	24AHSL48HM (RCSL-H*4824A*)	47,500 [13.9]	35,000 [10.3]	12,500 [3.7]	11.30	13.00	76	1,525 [720]
	RHKL-HM4824 (RCSL-H*4824A*)	48,500 [14.2]	36,500 [10.7]	12,000 [3.5]	12.10	14.00	76	1,625 [767]
RHLL-HM4824 (RCSL-H*4824A*)	48,500 [14.2]	36,450 [10.7]	12,050 [3.5]	12.15	14.00	76	1,625 [767]	
RHSL-HM4824 (RCSL-H*4824A*)	47,500 [13.9]	35,000 [10.3]	12,500 [3.7]	11.30	13.00	76	1,525 [720]	
060CAZ/ DAZ/JAZ/YAZ	RCFL-A*6024B*	61,000 [17.9]	42,900 [12.6]	18,100 [5.3]	11.10	13.00	76	1,800 [849]
	RCFL-H*6024A*	61,000 [17.9]	42,900 [12.6]	18,100 [5.3]	11.10	13.00	76	1,800 [849]
	RCHL-60A1	56,000 [16.4]	37,600 [11.0]	18,400 [5.4]	10.20	12.00	76	2,000 [944]
	RBHC-24 (RCHL-60A1)	55,000 [16.1]	35,900 [10.5]	19,100 [5.6]	10.10	12.00	76	1,800 [849]
	RBHP-25 (RCHL-60A1)	55,500 [16.3]	36,600 [10.7]	18,900 [5.5]	10.75	13.00	76	1,800 [849]
	RCQD-6024A*	58,500 [17.1]	40,250 [11.8]	18,250 [5.3]	10.95	13.00	76	1,800 [849]
	24AHLL60HM (RCSL-H*6024A*)	62,000 [18.2]	43,500 [12.7]	18,500 [5.4]	11.70	13.50	76	1,800 [849]
	RHKL-HM6024 (RCSL-H*6024A*)	62,000 [18.2]	43,450 [12.7]	18,550 [5.4]	11.70	13.50	76	1,800 [849]
	RHLL-HM6024 (RCSL-H*6024A*)	62,000 [18.2]	43,500 [12.7]	18,500 [5.4]	11.70	13.50	76	1,800 [849]
RHSL-HM6024 (RCSL-H*6024A*)	60,500 [17.7]	42,450 [12.4]	18,050 [5.3]	10.75	12.00	76	1,750 [826]	

① Highest sales volume tested combination required by D.O.E. test procedures.

[ ] Designates Metric Conversions

# Electrical and Physical Data: RANL-

Model No. RANL-	ELECTRICAL							PHYSICAL						
	Phase Frequency (Hz) Voltage (Volts)	Compressor		Fan Motor Full Load Amperes (FLA)	Min. Circuit Ampacity Amperes	Fuse or HACR Circuit Breaker		Outdoor Coil			Refrig. Per Circuit Oz. [g]	Weight		
		Rated Load Amperes (RLA)	Locked Rotor Amperes (LRA)			Min. Amperes	Max. Amperes	Face Area Sq. Ft. [m <sup>2</sup> ]	No. Rows	CFM [L/s]		Net Lbs. [kg]	Shipping Lbs. [kg]	
018JAZ	1-60-208/230	9/9	48	0.6	12/12	15/15	20/20	9.07 [0.84]	1	1775 [838]	70 [1984]	130 [59.0]	140 [63.5]	
024JAZ	1-60-208/230	12.8/12.8	58.3	0.6	17/17	20/20	25/25	11.00 [1.02]	1	1920 [906]	72 [2041]	140 [63.5]	150 [68.0]	
031JAZ	1-60-208/230	14.1/14.1	73	0.6	19/19	25/25	30/30	11.06 [1.03]	1	1920 [906]	83 [2353]	143 [64.9]	153 [69.4]	
037CAZ	3-60-208/230	13.2/13.2	88	1.2	18/18	25/25	30/30	16.10 [1.50]	1	3200 [1510]	106 [3005]	193 [87.5]	203 [92.1]	
037DAZ	3-60-460	6	44	0.6	9	15	15	16.10 [1.50]	1	3200 [1510]	106 [3005]	193 [87.5]	203 [92.1]	
037JAZ	1-60-208/230	17.9/17.9	112	1.2	24/24	30/30	40/40	16.10 [1.50]	1	3200 [1510]	106 [3005]	193 [87.5]	203 [92.1]	
043CAZ	3-60-208/230	13.6/13.6	83.1	1.2	19/19	25/25	30/30	16.10 [1.50]	1	3200 [1510]	115 [3260]	202 [91.6]	212 [96.2]	
043DAZ	3-60-460	6.1	41	0.6	9	15	15	16.10 [1.50]	1	3200 [1510]	115 [3260]	202 [91.6]	212 [96.2]	
043JAZ	1-60-208/230	19.9/19.9	109	1.2	27/27	35/35	45/45	16.10 [1.50]	1	3200 [1510]	115 [3260]	202 [91.6]	212 [96.2]	
049CAZ	3-60-208/230	13.7/13.7	83.1	1.2	19/19	25/25	30/30	20.13 [1.87]	1	3500 [1652]	132 [3742]	214 [97.1]	224 [101.6]	
049DAZ	3-60-460	6.2	41	0.6	9	15	15	23.13 [2.15]	1	3500 [1652]	132 [3742]	214 [97.1]	224 [101.6]	
049JAZ	1-60-208/230	21.8/21.8	117	1.2	29/29	35/35	50/50	20.13 [1.87]	1	3500 [1652]	132 [3742]	214 [97.1]	224 [101.6]	
049YAZ	3-60-575	4.8	33	0.5	7	15	15	20.13 [1.87]	1	3500 [1652]	132 [3742]	214 [97.1]	224 [101.6]	
060CAZ	3-60-208/230	15.6/15.6	110	1.2	21/21	25/25	35/35	23.01 [2.14]	1	3500 [1652]	180 [5103]	250 [113.4]	260 [117.9]	
060DAZ	3-60-460	7.8	52	0.6	11	15	15	23.01 [2.14]	1	3500 [1652]	180 [5103]	250 [113.4]	260 [117.9]	
060JAZ	1-60-208/230	26.3/26.3	134	1.2	35/35	45/45	60/60	23.01 [2.14]	1	3500 [1652]	180 [5103]	250 [113.4]	260 [117.9]	
060YAZ	3-60-575	5.8	38.9	0.5	8	15	15	23.01 [2.14]	1	3500 [1652]	180 [5103]	250 [113.4]	260 [117.9]	

[ ] Designates Metric Conversions

# Unit Dimensions

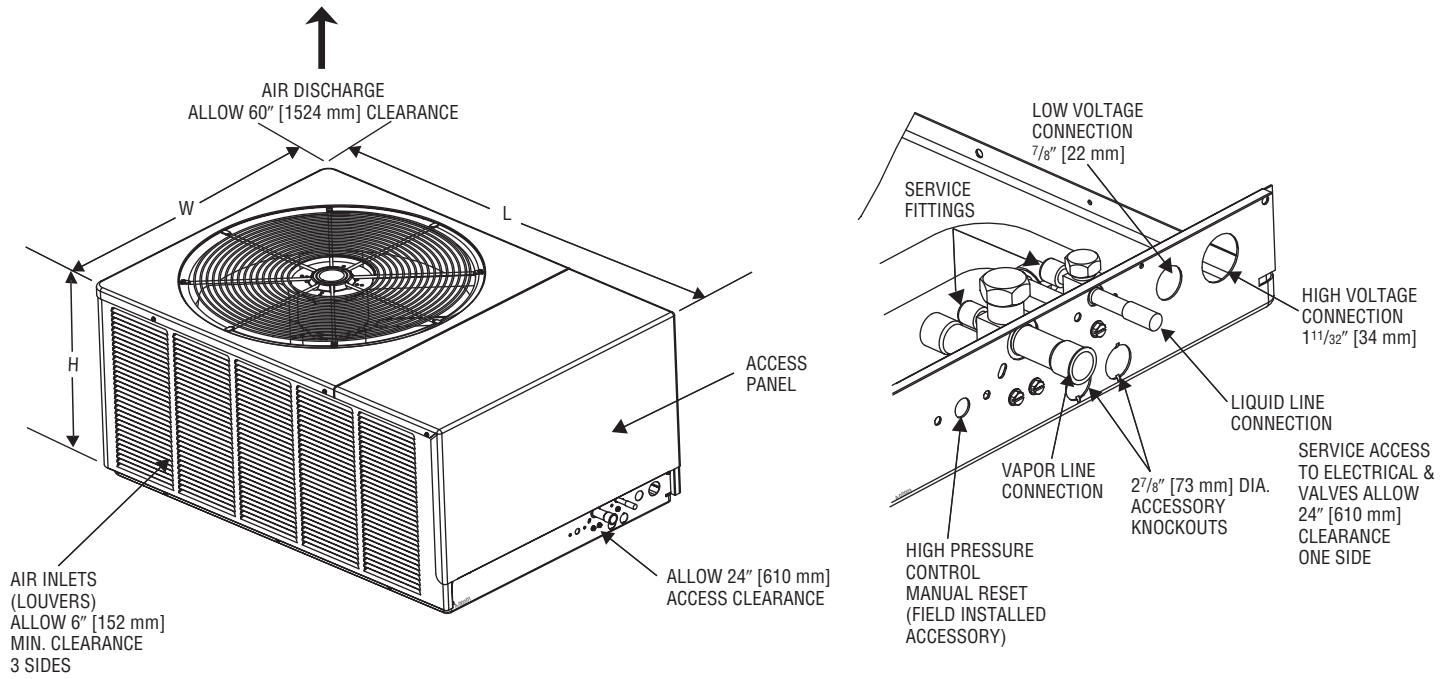

Model Number RANL-	Height "H" (Inches) [mm]	Length "L" (Inches) [mm]	Width "W" (Inches) [mm]
018	19 [483]	35 1/2 [902]	23 3/4 [603]
024/031	19 [483]	40 1/2 [1029]	27 5/8 [702]
037/043	23 [584]	44 3/8 [1127]	31 1/2 [800]
049	29 [737]	44 3/8 [1127]	31 1/2 [800]
060	33 [838]	44 3/8 [1127]	31 1/2 [800]

[ ] Designates Metric Conversions

**BEFORE PURCHASING THIS APPLIANCE, READ IMPORTANT ENERGY COST AND EFFICIENCY INFORMATION AVAILABLE FROM YOUR RETAILER.**

## GENERAL TERMS OF LIMITED WARRANTY

Rheem will furnish a replacement for any part of this product which fails in normal use and service within the applicable period stated, in accordance with the terms of the limited warranty.

**For Complete Details of the Limited Warranty, Including Applicable Terms and Conditions, See Your Local Installer or Contact the Manufacturer for a Copy.**

Condenser Coil leaks caused by  
factory defects .....Five (5) Years

Compressor—  
JAZ .....Ten (10) Years  
CAZ, DAZ, YAZ.....Five (5) Years

\*All Other Parts  
JAZ .....Five (5) Years  
CAZ, DAZ, YAZ .....One (1) Year

**\*This five year limited warranty is applicable only to single-phase products installed in residential applications on or after January 1, 2001.**

# Condensing Unit Refrigerant Line Size Information

Liquid Line Sizing (R-410A)														
System Capacity	Line Size Connection (Inch I.D.)	Line Size (Inch O.D.) [mm]	Liquid Line Size – Outdoor Unit Above Indoor Coil (Cooling Only – Does not apply to Heat Pumps)						Liquid Line Size – Outdoor Unit Below Indoor Coil					
			Total Equivalent Length—Feet [m]						Total Equivalent Length—Feet [m]					
			25 [7.62]	50 [15.24]	75 [22.86]	100 [30.48]	125 [38.10]	150 [45.72]	25 [7.62]	50 [15.24]	75 [22.86]	100 [30.48]	125 [38.10]	150 [45.72]
			Minimum Vertical Separation—Feet [m]						Maximum Vertical Separation—Feet [m]					
1 1/2 Ton	3/8"	1/4 [6.35]	0	0	0	0	8 [2.44]	24 [7.32]	25 [7.62]	40 [12.19]	25 [7.62]	9 [2.74]	N/A	N/A
		5/16 [7.94]	0	0	0	0	0	0	25 [7.62]	50 [15.24]	62 [18.90]	58 [17.68]	53 [16.15]	49 [14.94]
		3/8* [9.53]	0	0	0	0	0	0	25 [7.62]	50 [15.24]	75 [22.86]	72 [21.95]	70 [21.34]	68 [20.73]
2 Ton	3/8"	1/4 [6.35]	0	3 [0.91]	29 [8.84]	55 [16.76]	81 [24.69]	108 [32.92]	23 [7.01]	N/A	N/A	N/A	N/A	N/A
		5/16 [7.94]	0	0	0	0	0	0	25 [7.62]	36 [10.97]	29 [8.84]	23 [7.01]	16 [4.88]	9 [2.74]
		3/8* [9.53]	0	0	0	0	0	0	25 [7.62]	50 [15.24]	72 [21.95]	70 [21.34]	68 [20.73]	65 [19.81]
2 1/2 Ton	3/8"	1/4 [6.35]	0	14 [4.27]	56 [17.07]	98 [29.87]	N/A	N/A	25 [7.62]	N/A	N/A	N/A	N/A	N/A
		5/16 [7.94]	0	0	0	0	0	0	25 [7.62]	49 [14.94]	38 [11.58]	27 [8.23]	17 [5.18]	6 [1.83]
		3/8* [9.53]	0	0	0	0	0	0	25 [7.62]	50 [15.24]	68 [20.73]	65 [19.81]	62 [18.90]	58 [17.68]
3 Ton	3/8"	5/16 [7.94]	0	0	0	0	0	9 [2.74]	25 [7.62]	50 [15.24]	37 [11.28]	22 [6.71]	7 [2.13]	N/A
		3/8* [9.53]	0	0	0	0	0	0	25 [7.62]	50 [15.24]	68 [20.73]	63 [19.20]	58 [17.68]	53 [16.15]
3 1/2 Ton	3/8"	5/16 [7.94]	0	0	0	16 [4.88]	35 [10.67]	54 [16.46]	25 [7.62]	23 [7.01]	4 [1.22]	N/A	N/A	N/A
		3/8* [9.53]	0	0	0	0	0	0	25 [7.62]	50 [15.24]	43 [13.11]	36 [10.97]	30 [9.14]	24 [7.32]
4 Ton	3/8"	3/8* [9.53]	0	0	0	0	0	0	25 [7.62]	46 [14.02]	38 [11.58]	30 [9.14]	22 [6.71]	15 [4.57]
		1/2 [12.57]	0	0	0	0	0	0	25 [7.62]	50 [15.24]	56 [17.07]	55 [16.76]	53 [16.15]	52 [15.85]
5 Ton	3/8"	3/8* [9.53]	0	0	0	0	0	0	25 [7.62]	50 [15.24]	56 [17.07]	44 [13.41]	32 [9.75]	20 [6.10]
		1/2 [12.57]	0	0	0	0	0	0	25 [7.62]	50 [15.24]	75 [22.86]	81 [24.69]	79 [24.08]	76 [23.16]

NOTES: \*Standard line size  
N/A = Application not recommended.

Suction Line Length/Size versus Capacity Multiplier (R-410A)									
Unit Size	1 1/2 Ton	2 Ton	2 1/2 Ton		3 Ton	3 1/2 Ton	4 Ton	5 Ton	
Suction Line Connection Size	3/4" [19.05 mm] I.D.				7/8" [22.23 mm] I.D.				
Suction Line Run—Feet [m]	5/8" [15.88 mm] O.D. Opt. 3/4" [19.05 mm] O.D. Std.*		5/8" [15.88 mm] O.D. Opt. 3/4" [19.05 mm] O.D. Std.* 7/8" [22.23 mm] O.D. Opt.		3/4" [19.05 mm] O.D. Opt. 7/8" [22.23 mm] O.D. Std.*		7/8" [22.23 mm] O.D. Opt. 1 1/8" [28.58 mm] O.D. Std.*		
25' [7.62]	Optional	1.00	1.00	1.00		1.00	1.00	1.00	1.00
	Standard	1.00	1.00	1.00		1.00	1.00	1.00	1.00
	Optional	N/A	N/A	1.00		N/A	N/A	N/A	N/A
50' [15.24]	Optional	.98	.98	.96		.98	.99	.99	.99
	Standard	.99	.99	.98		.99	.99	.99	.99
	Optional	N/A	N/A	.99		N/A	N/A	N/A	N/A
100' [30.48]	Optional	.95	.95	.94		.96	.96	.96	.97
	Standard	.96	.96	.96		.97	.98	.98	.98
	Optional	N/A	N/A	.97		N/A	N/A	N/A	N/A
150' [45.72]	Optional	.92	.92	.91		.94	.94	.95	.94
	Standard	.93	.94	.93		.95	.96	.96	.97
	Optional	N/A	N/A	.95		N/A	N/A	N/A	N/A

NOTES: \*Standard line size  
Using suction line larger than shown in chart will result in poor oil return and is not recommended.

[ ] Designates Metric Conversions

<p><b>Before proceeding with installation, refer to installation instructions packaged with each model, as well as complying with all Federal, State, Provincial, and Local codes, regulations, and practices.</b></p>	<p><b>Rheem Heating, Cooling and Water Heating</b></p> <p>P.O. Box 17010, Fort Smith, AR 72917</p>	
------------------------------------------------------------------------------------------------------------------------------------------------------------------------------------------------------------------------	------------------------------------------------------------------------------------------------------------	---------------------------------------------------------------------------------------

"In keeping with its policy of continuous progress and product improvement, Rheem reserves the right to make changes without notice."