

SUBMITTAL DATA: MSZ-FD09NA & MUZ-FD09NA
9,000 BTU/H WALL MOUNTED HEAT PUMP SYSTEM

Job Name: _____	Location: _____	Date: _____
Purchaser: _____	Engineer: _____	
Submitted to: _____	For <input type="checkbox"/> Reference <input type="checkbox"/> Approval <input type="checkbox"/> Construction	
Unit Designation: _____	Schedule No.: _____	

GENERAL FEATURES

- Highly energy-efficient system with quiet operation
- Updated sleek, compact indoor unit design
- Includes Standard, Platinum Deodorizing, and Anti-allergy Enzyme Filters for a complete air purifying system
- “Powerful Mode” function permits system to temporarily run at a lower/higher temperature with an increased fan speed, which quickly brings the room to the optimum comfort level
- Integrated i-see sensor automatically detects room air temperature
- Autochangeover for cooling and heating
- Wireless remote controller
- Limited warranty: one year on parts and defects; six years on compressor

OPTIONAL ACCESSORIES
Outdoor Unit

- Drain Socket (MAC-851DS)

Indoor Unit

- M-NET Control Adapter (MAC-399IF)
- MA Contact Terminal Interface (MAC-397IF)
- Wired Remote Controller (PAR-21MAA; Requires MAC-397IF)
- Centralized On/Off Remote Controller (MAC-821SC; Up to eight units, requires one MAC-397IF per indoor unit)
- Condensate Pump (SI3100-230; 230V)
- Replacement Platinum Deodorizing Filter (MAC-308FT)
- Replacement Anti-allergy Enzyme Filter (MAC-418FT; MERV 8)

Cooling*

Rated Capacity 9,000 Btu/h
 Minimum Capacity 2,800 Btu/h
 SEER 23.0 Btu/h/W
 Total Input 650 W

Heating at 47° F*

Rated Capacity 10,900 Btu/h
 Minimum Capacity 3,000 Btu/h
 HSPF 10.55 Btu/h/W
 Total Input 750 W

Heating at 17° F*

Rated Capacity 12,500 Btu/h
 Total Input 1,730 W

* Rating Conditions (Cooling) - Indoor: 80°F (27°C) DB, 67°F (19°C) WB; Outdoor: 95°F (35°C) DB, 75°F (24°C) WB.
 (Heating) - Indoor: 70°F (21°C) DB, 60°F (16°C) WB; Outdoor: 47°F (8°C) DB, 43°F (6°C) WB.
 (Heating) - Indoor: 70°F (21°C) DB, 60°F (16°C) WB; Outdoor: 17°F (-8°C) DB, 15°F (-9°C) WB

Power Supply 208 / 230V, 1-Phase, 60 Hz
 Breaker Size 15A

Voltage

Indoor - Outdoor S1-S2 AC 208 / 230V
 Indoor - Outdoor S2-S3 DC 12-24V
 Indoor - Remote Controller Wireless

OPERATING RANGE

		Indoor Intake Air Temp.	Outdoor Intake Air Temp.
Cooling	Maximum	90°F (32°C) DB, 73°F (23°C) WB	115°F (46°C) DB
	Minimum	67°F (19°C) DB, 57°F (14°C) WB	14°F (-10°C) DB
Heating	Maximum	80°F (27°C) DB, 67°F (19°C) WB	75°F (24°C) DB, 65°F (18°C) WB
	Minimum	70°F (27°C) DB, 60°F (16°C) WB	14°F (-10°C) DB, 13°F (-11°C) WB

Indoor Unit

MCA 1 A
 Fan Motor 0.76 F.L.A.
 Airflow
 Cooling (Lo - Med - Hi - Powerful) . . . 162 - 226 - 339 - 381 Dry CFM
 144 - 202 - 307 - 343 Wet CFM
 Heating (Lo - Med - Hi - Powerful) . . . 166 - 240 - 367 - 381 Dry CFM
 Sound Pressure Level
 Cooling (Lo - Med - Hi - Powerful) 22 - 31 - 39 - 42 dB(A)
 Heating (Lo - Med - Hi - Powerful) 22 - 31 - 40 - 42 dB(A)

DIMENSIONS	UNIT INCHES / MM
W	31-7/16 / 799
D	10-1/8 / 257
H	11-5/8 / 295

Weight 27 lbs. / 12 kg
 External Finish Munsell No. 1.0Y 9.2 / 0.2
 Field Drainpipe Size O.D. 5/8" / 15.88 mm

Outdoor Unit

Compressor DC Inverter-driven Rotary
 MCA 12 A
 Fan Motor 0.56 F.L.A.
 Sound Pressure Level
 Cooling / Heating 48 / 49 dB(A)

DIMENSIONS	INCHES / MM
W	31-1/2 / 800
D	11-1/4 / 286
H	21-5/8 / 549

Weight 80 lbs. / 36 kg
 External Finish Munsell No. 3.0Y 7.8 / 1.1

Refrigerant Type R410A
 Refrigerant Pipe Size O.D.
 Gas Side 3/8" / 9.52 mm
 Liquid Side 1/4" / 6.35 mm
 Max. Refrigerant Pipe Length 65' / 20 m
 Max. Refrigerant Pipe Height Difference 40' / 12 m
 Connection Method Flared



DIMENSIONS: MSZ-FD09NA & MUZ-FD09NA

MSZ-FD09NA

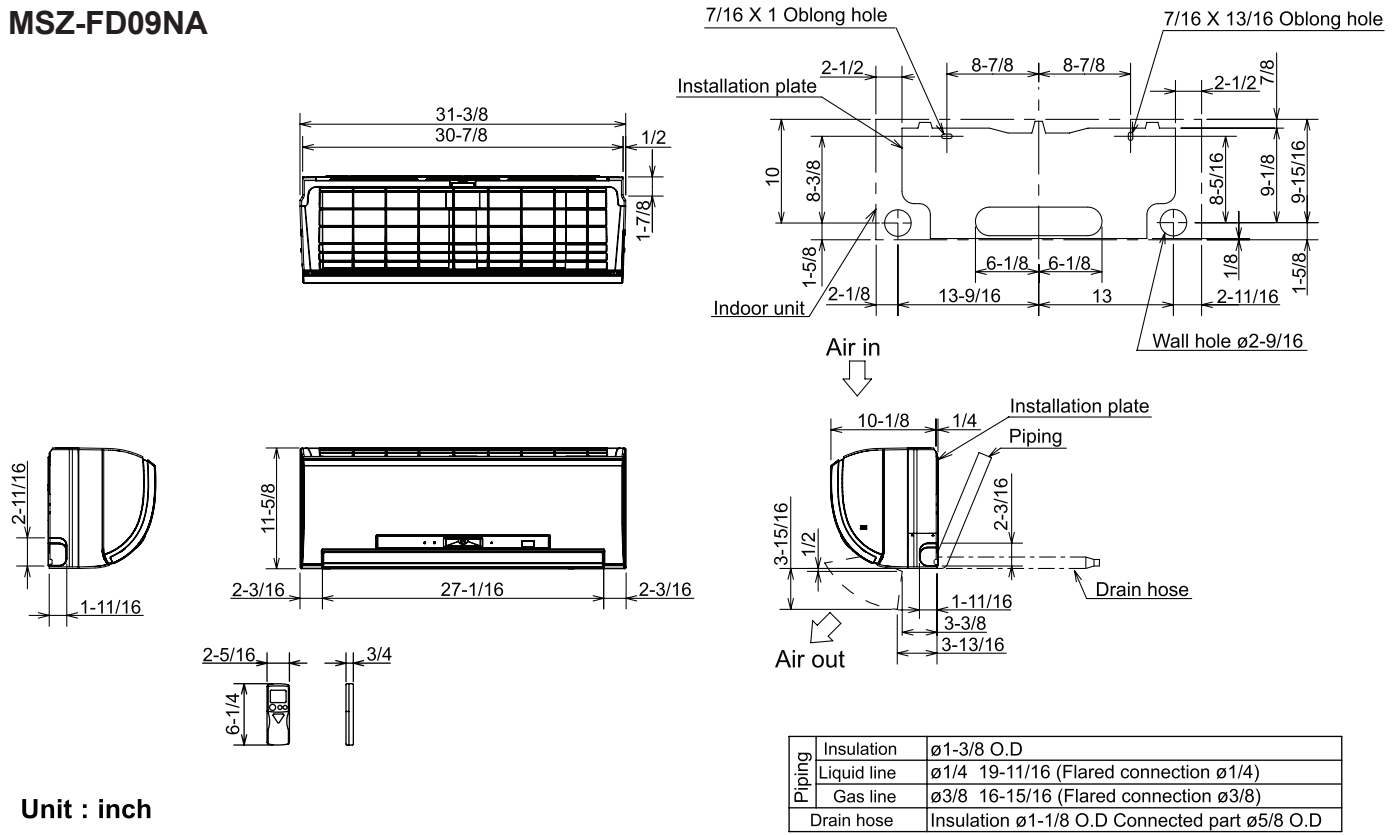

MUZ-FD09NA

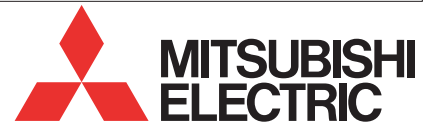
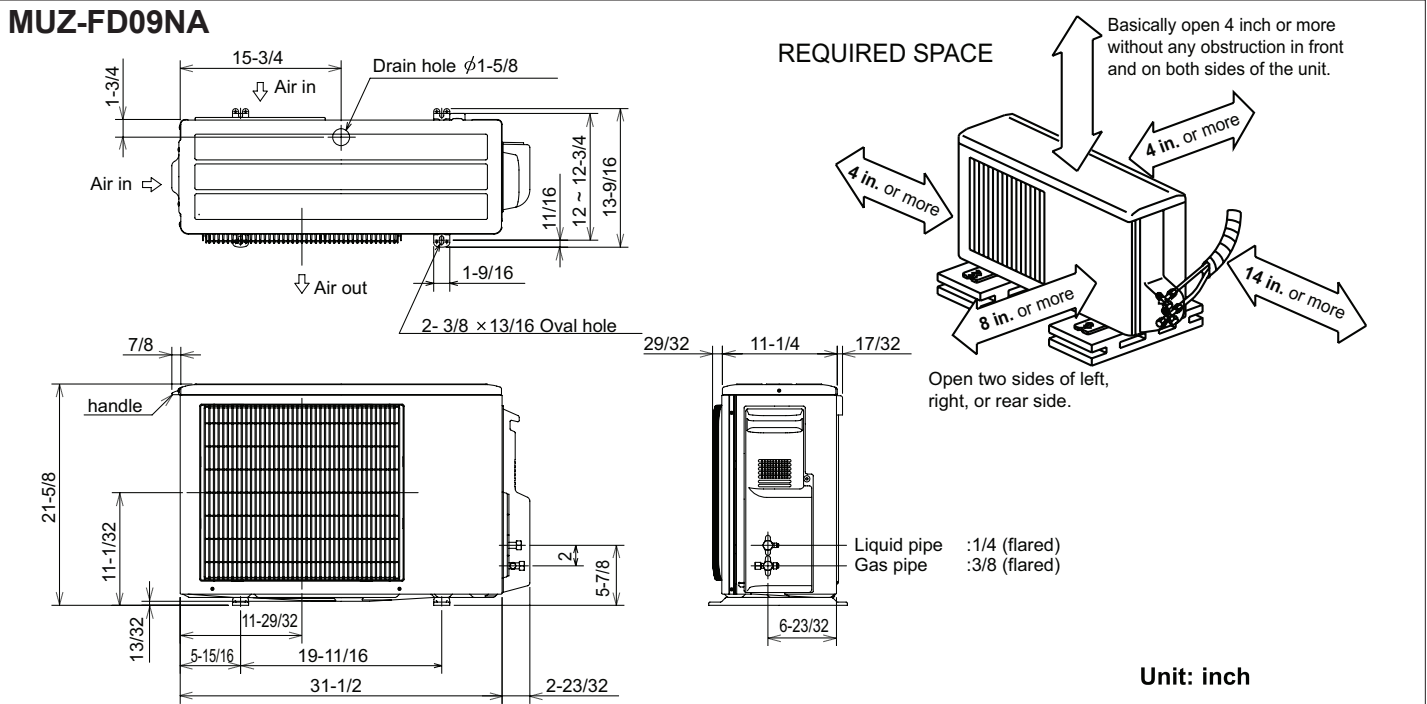

HVAC Advanced Products Division
3400 Lawrenceville Suwanee Rd
Suwanee, GA 30024
Tele: 678-376-2900 • Fax: 800-889-9904
Toll Free: 800-433-4822 (#3)
www.mehvac.com
Specifications are subject to change without notice.