

Job Name : _____
 Purchaser : _____
 Engineer : _____
 Submitted To : _____
 Submitted By : _____
 Unit Designation : Schedule No.: _____

Location : _____
 P.O. No. : _____
 Architect : _____
 Date : _____
 For : Reference Approval Construction
 Model No.: _____



Submittal Data : PTAC & PTHP - 230/208V

Standard Features :

- Five Year Parts and Labor Warranty on Sealed Refrigerant System
- One Year Full System Warranty on Parts and Labor, 2-5 Year Parts
- R-22 Refrigerant
- Ultra Quiet Operation *
- High Energy Efficiency
- Digital Control Display *
- Gold Fin™ Anti-corrosion Treatment for Condenser
- Auto Restart
- Energy Saver Mode
- Front Desk Control
- Freeze Room Protection
- Dip Switch setting for temperature limiting
- Temperature Display on unit *
- Fresh Air Ventilation, 70 CFM @ 0.3 ESP with Open Damper Door
- Unit Dimension (inches, WxHxD) : 42 x 16 x 19 7/8

* Not available for Mechanical Control models LP091CEM-Y8, LP121CEM-Y8, LP091HEM-Y8, LP121HEM-Y8

Unit

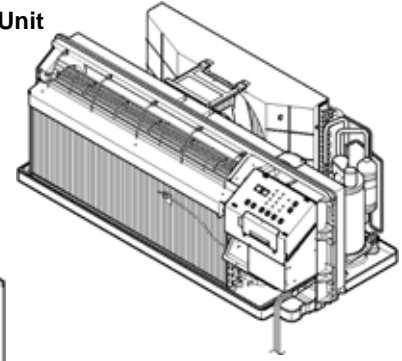

Front Grille Assembly

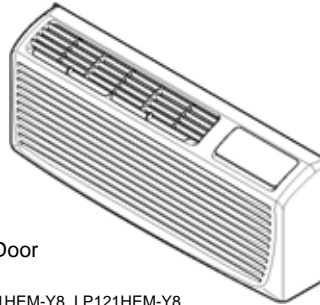

Unit Specification :

| Model No. | Cooling Capacity (Btu/h) | EER | Heating Capacity (Btu/h) | COP | Electric Heater (kW) | Power Supply (V, Ph, Hz) | Air Circulation (CFM, H/L) | Dehumidification (pts/hr) | Running Current (Amps) | | Power Input (Watts) | | Maximum Overcurrent Protection (A) | Weight Net/Gross (lbs) |
|-------------|--------------------------|------|--------------------------|-----|----------------------|--------------------------|----------------------------|---------------------------|------------------------|---------|---------------------|-------------|------------------------------------|------------------------|
| | | | | | | | | | Cooling | Heating | Cooling | Heating | | |
| LP070CED-Y8 | 7,600/7,400 | 12.5 | - | - | 2.5/2.4 | 230/208,1,60 | 335/300 | 2.0 | 2.8/3.0 | - | 610/590 | - | 15 | 96/100 |
| LP090CED-Y8 | 9,000/8,800 | 11.7 | - | - | 3.5/3.1 | 230/208,1,60 | 335/300 | 2.6 | 3.5/3.8 | - | 770/750 | - | 20 | 92/96 |
| LP120CED-Y8 | 11,800/11,500 | 11.2 | - | - | 3.5/3.1 | 230/208,1,60 | 390/355 | 3.3 | 4.8/5.2 | - | 1,055/1,025 | - | 20 | 103/107 |
| LP150CED-Y8 | 14,300/14,100 | 10.0 | - | - | 3.5/3.1 | 230/208,1,60 | 390/355 | 4.4 | 6.5/7.1 | - | 1,430/1,410 | - | 20 | 111/115 |
| LP070HED-Y8 | 7,600/7,400 | 12.1 | 6,400/6,200 | 3.5 | 2.5/2.4 | 230/208,1,60 | 335/300 | 2.0 | 2.9/3.0 | 2.4/2.6 | 630/610 | 535/520 | 15 | 103/107 |
| LP090HED-Y8 | 9,000/8,800 | 11.6 | 8,100/7,900 | 3.4 | 3.5/3.1 | 230/208,1,60 | 335/300 | 2.6 | 3.6/3.8 | 3.2/3.4 | 775/760 | 700/680 | 20 | 98/102 |
| LP120HED-Y8 | 12,000/11,800 | 10.8 | 10,900/10,700 | 3.3 | 3.5/3.1 | 230/208,1,60 | 390/355 | 3.3 | 5.0/5.4 | 4.4/4.8 | 1,110/1,090 | 970/950 | 20 | 111/115 |
| LP150HED-Y8 | 14,300/14,100 | 9.8 | 13,500/13,300 | 3.1 | 3.5/3.1 | 230/208,1,60 | 390/355 | 4.4 | 6.7/7.3 | 5.8/6.3 | 1,460/1,440 | 1,275/1,255 | 20 | 116/120 |
| LP091CEM-Y8 | 8,900/8,800 | 11.0 | - | - | 3.5/3.1 | 230/208,1,60 | 390/355 | 2.5 | 3.6/3.8 | - | 810/800 | - | 20 | 92/96 |
| LP121CEM-Y8 | 11,500/11,300 | 10.8 | - | - | 3.5/3.1 | 230/208,1,60 | 390/355 | 3.2 | 4.6/5.0 | - | 1,065/1,045 | - | 20 | 108/112 |
| LP091HEM-Y8 | 8,700/8,500 | 10.8 | 7,500/7,300 | 3.2 | 3.5/3.1 | 230/208,1,60 | 300/265 | 2.5 | 3.7/4.0 | 3.2/3.4 | 805/785 | 695/675 | 20 | 85/89 |
| LP121HEM-Y8 | 11,500/11,300 | 10.0 | 10,500/10,300 | 3.1 | 3.5/3.1 | 230/208,1,60 | 390/355 | 3.2 | 5.2/5.6 | 4.4/4.8 | 1,150/1,130 | 995/975 | 20 | 115/119 |

Accessories :

| | | | |
|-----------------------------------|------------|---------------------------------------|----------|
| Wall Sleeve (42"Wx16"Hx13 3/4"D) | AYSVB01A | Remote Escutcheon Kit (10 pack) | AYRE110 |
| Stamped Aluminum Grille | AYRGALA01 | Wall Thermostat Connection Kit | AYWH101 |
| Architecture Grille - Aluminum | AYAGALA01A | EMS/Front Desk Control Connection Kit | AYFD101 |
| Architecture Grille - Dark Bronze | AYAGALB01A | Condensate Drain Kit | AYDR101 |
| Architecture Grille - Soft Dove | AYAGALC01A | Condensate Disposal Kit (230/208V) | AYCD2101 |
| Sub Base (230/208V 20A) | AYSB1101A | Hard Wire Kit | AYHW101 |
| Sub Base (230/208V 30A) | AYSB2101A | Fuse Holder Kit (230/208V 30A) | AYFH1401 |
| Leveling Legs | AYLL101 | Replacement Filter (10 pack) | AYFT110 |
| Lateral Duct Kit | AYLD1A | Control Panel Key Lock | AYCP101 |

Wall Thermostats :

| | |
|--|-----------|
| Wired Wall Thermostat | PYRCUCA0A |
| Wireless Wall Thermostat | PYRCUCC0A |
| Current Tap (for Wireless Wall Thermostat) | PYRCUCC1A |
| Adaptor Kit of Wireless Thermostat (for GE) | PYADTGE1A |
| Adaptor Kit of Wireless Thermostat (for Amana) | PYADTAM1A |

Note :