

Job Name: _____
 Purchaser: _____
 Engineer: _____
 Submitted To: _____
 Submitted By: _____
 Unit Designation / Schedule No: _____

Location: _____
 P.O No. : _____
 Architect: _____
 Date: _____
 For: Reference Approval Construction
 Model No: _____

Submittal Data :



Standard Features:

- 6 Year Compressor Warranty
- 1 Year Functional Parts
- 1 Year Full Condenser Replacement
- Earth Friendly Refrigerant R410A
- 24 Hour On / Off Timer
- Auto-Restart after power loss
- Low Ambient Operations
- LCD Wireless Remote Controller
- Temperature Display on Indoor Unit
- Washable, Reusable Air Filters

Capacities:

Cooling (BTU):	12,000
Heating (BTU):	15,500
Cooling Range (BTU):	6,500 - 14,500
Heating Range (BTU):	5,300 - 16,300
Power Supply (V, Ph, Hz):	115 - 1 - 60
SEER:	20.0
EER:	13.65
HSPF:	10.1
Refrigerant Type:	R410A
Low Ambient Cooling (Fahrenheit):	21 Degree
Low Ambient Heating (Fahrenheit):	-7 Degree

Indoor Unit Specs:

Model Number:	GSU121HX
Maximum Fuse Size:	Wired from Outdoor Unit
Minimum Fuse Size:	Wired from Outdoor Unit
Weight (lbs):	31
Sound Rating low/med/high(dB):	35 - 38 - 42
Input Power (Watts):	771
Input Current (Amps):	7.83

Outdoor Units Specs:

Model Number:	GSU121HX
Maximum Fuse Size (Amp):	20
Minimum Fuse Size (Amp):	15
Weight (lbs):	99
Sound Rating (dB):	57
Compressor Brand:	Panasonic

Refrigerant Piping Information:

Maximum Length (ft):	88
Maximum Height Difference (ft):	66
Liquid Side (O.D):	1/4"
Suction Side (O.D):	1/2"

GSU121HX (INDOOR UNIT):

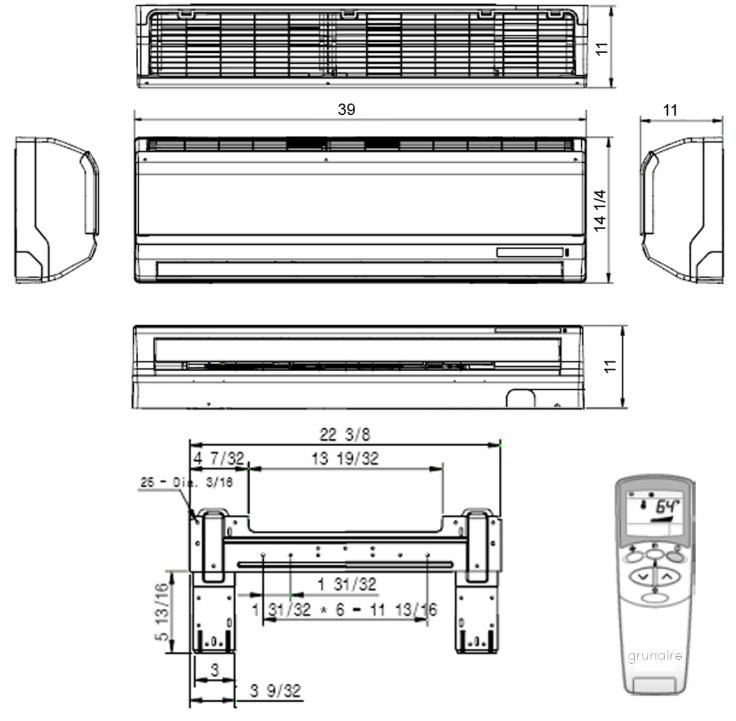

GSU121HX (OUTDOOR UNIT):

